

Hotel Energy Switch

Features:

- AC220V (AC110V)
- 6000w Rated load
- Frequency of 125 KHZ
- 8-12 seconds delay
- ABS material

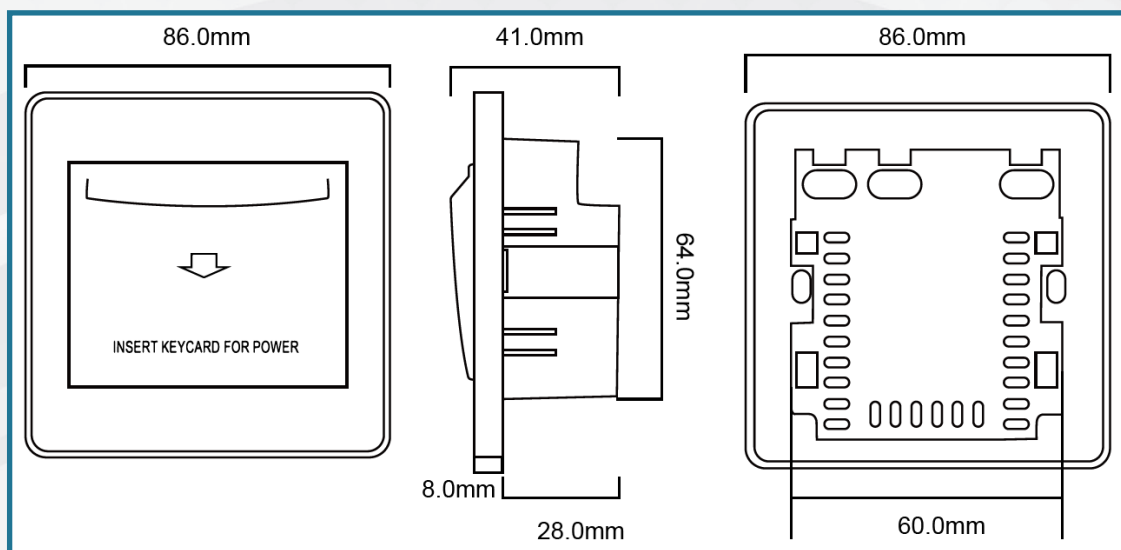

Model	READERH125
Size(mm)	86L*86W*28H
Operating Voltage	AC220V (AC110V)
Rated load	6000W
Frequency	125KHz
Time Delay	8s -12s
Panel logo	Customizable
Accessories	Optional Back Box
Operating Temp	-20°C to +55°C (-4 to 131°F)
Operating humidity	0-95% (RH)
Weight(KG)	0.13
Package Quantity	1 PCS/box, 100 PCS/ctn.