

D-TECT Pet Immune

GJD370/371/372 Motion Detector



INTRODUCTION

An event trigger utilising two independent passive infrared detectors and a microwave sensor. Both PIR sensors and the microwave have to trigger before the detector signals an alarm. The high precision, very reliable presence detector has been designed for use within monitored installations and will alarm if tampered by masking.

The integral dual axis tilt sensor allows 180° of pan and 30° tilt. This increases the speed of the outdoor installation and provides incredibly accurate aiming of the detection pattern. The electronics module is acrylic coated for additional component stability. It is encased in a vandal-resistant high impact ABS housing with a UV stabilised translucent front cover ensuring the sensor is impervious to and unaffected by weather conditions. Additionally the combination of precision electronics, digital white light filter and double shielding eliminates false alarms from the sun and other visible light sources.

The Pet Immune design gives a neat and professional appearance with no visible indication of the orientation of the detector head, and totally hides the wiring.

QUICK INSTALLATION GUIDE

Apply supply voltage to the unit, the amber led flashes 10 times, then the blue LED flashes 3 times.

The detector takes approximately 2-3 minutes to settle. The walk test led is enabled for 5 minutes after power is applied

THE FRONT COVER MUST BE FITTED WHEN WALK TESTING

FACTORY SETTINGS ARE:

- 1 RANGE 15 METRES
- 2 PULSE COUNT 1
- 3 LED OFF

When enabled the D-TECT Pet Immune has four LED indicators.

Green – Bottom PIR

Red – Top PIR

Blue – Alarm output, both PIRs and microwave detection

Amber - Anti-Mask detection

ANTI-MASKING CIRCUIT

The cover must be fitted before applying power to the detector.

During the first 10 seconds after power has been connected, the amber LED flashes and the anti-masking circuit starts to self-calibrate. The amber LED indicates when the detector is covered, but the relay contacts do not operate until the unit has been covered for 60 seconds.

SEQUENCE FOR CORRECT AM OPERATION

1. Make connection and replace cover.
2. Apply 12 volts power. Amber LED Flashes 10 times - self calibration completed.
3. Cover detector for 60 seconds. When anti-mask detection is continuous for 60 seconds the normally closed relay will open until anti-mask detection is cleared.

STAGE 1 - Mounting the unit



WARNING

- NYLON WASHERS PROVIDED MUST BE USED WITH SCREWS
- ENSURE CABLE ENTRY AND SCREW HOLES ARE SEALED WITH WATER BASED SEALANT
- DO NOT USE SILICONE BASED SEALANT

To reduce the possibility of the microwave circuit being affected it is recommended to leave a minimum space of 3 metres between D-TECT Pet Immune sensors when mounted alongside each other. When facing each other a minimum space of 15 metres is recommended. It is possible to mount the units back to back however when detectors are mounted in close proximity to one another it is advisable to carry out a walk test to ensure that external objects are not influencing the microwave circuit.

- During installation the electronics must be protected against water, as trapped moisture can affect or damage the unit.

1. Using the template provided drill the wall to accept the two fixing screws, the cable entry and the tamper cup (if used). See fig 1 and 2.

Note: We recommend using the tamper cup on uneven wall surfaces.

2. Remove the cover assembly by loosening the locking screw. The cover hinges from the top and lifts out of the location slot. See fig 3.

3. Feed standard 8 core alarm cable into the cable entry; bare the wires and connect to the terminal block as shown in fig 7. Screw the unit to the wall ensuring that the tamper pin is correctly located and that the tamper switch is closed. See fig 4 and 5. To aid installation, two spare tamper feet are provided. One is 1mm longer and the other is 2mm longer than the tamper foot originally fitted. The tamper foot is a push fit and can be removed by carefully pulling it from the pin. See fig 2.

4. When the detector has been aligned to suit the installation, replace the front cover and lock as shown. See fig 6.

STAGE 2 - Connecting the Unit

⊕ ⊕	⊕ ⊕	⊕ ⊕	⊕ ⊕	⊕ ⊕	⊕ ⊕
A/M	ALARM/NC	TAMPER	ALARM/NO	+ 9-15	- VDC

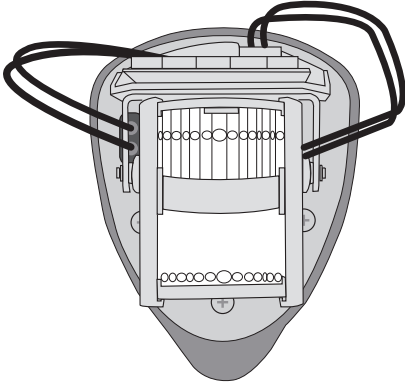

STAGE 3 - Multibeam Alignment & Masking

The GJD lenses fitted to the D-TECT detector produce 7 long range beams and 7 medium to short range curtain beams. Movement across the beams produces the best response and range for the PIRs, whilst movement towards the detector produces the best response for the microwave sensor. The unit detects the changes in heat and movement in the beam pattern, therefore items such as trees, shrubs, ponds, boiler flues and large animals should be considered when positioning the detector.

The detector module is fitted with two sliding shutters to reduce the detection angle. An additional set of curtains is provided should the beam pattern need to be narrowed even further e.g. if the minimum detection angle of 10 degrees is required.

The curtains are fitted to the pan and tilt module as indicated in fig 8. Each section of the detectors lens gives a coverage pattern of around 10 degrees.

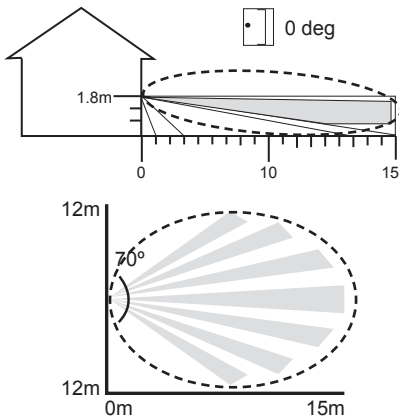

STAGE 4 - Programming

The user can individually configure the detector's settings.

ADJUST RANGE

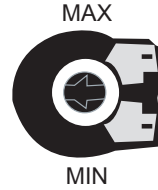

SET PULSE COUNT

- SW1 OFF SW2 OFF = 1
- SW1 ON SW2 OFF = 2
- SW1 OFF SW2 ON = 3
- SW1 ON SW2 ON = 4

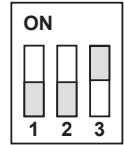

LED Monitor

- SW3 OFF = LEDs Disabled
- SW3 ON = LEDs Enabled

STAGE 5 - Walk Test

The range of the detector increase without the front protective cover. Therefore the front cover must be fitted to establish the correct beam pattern alignment and when testing the outputs. Use the programming chart to adjust the range as necessary and pan and tilt the lens module over the field of view to obtain the correct coverage area.

Walk test is enabled for five minutes after the power is connected. During this time the LEDs are enabled. After there has been no detection for five minutes the walk test will cancel. The LED indicators can be permanently enabled by turning SW3 to ON.

STAGE 6 - OPTION Definitions

PULSE COUNT

This is the number of times the unit has to detect on both of its sensors before signaling an output.

LED MONITOR

- LED Off - LED disabled.
- LED on - LEDs signal a detection.

N/OPEN & N/CLOSED

These are magnetically immune volt free relay contacts used to trigger alarm inputs on connected equipment. The contacts are rated at a maximum of 24 AC/DC @ 50mA.

ACCESSORIES

GJD is able to supply the following accessory to aid installations:

- GJD305 Pole mount clamp

SIMPLIFIED EU DECLARATION OF CONFORMITY

Hereby, GJD Manufacturing Ltd declares that the radio equipment type GJD370/GJD371/GJD372 D-TECT Pet Immune Detector is in compliance with Directive 2014/53/EU.

The full text of the EU declaration of conformity is available at the following internet address: gjd.co.uk

SPECIFICATIONS

Detection Area	Up to 15m selectable	
Coverage	10-70 degrees detection angle	
Adjustment	180 degree pan + 30 degree tilt	
Fresnel Lens	14 zones for each Pyro pair, which can be masked with the curtain sliders	
Customised Optics	Double silicon shielded dual element eliminates 50,000 Lux of White-Light	
Microwave Module	Operating Frequency. Country dependent GJD370 10.525 GHz GJD371 10.587 GHz GJD372 9.9GHz	
Outputs	Silent solid state magnetically immune	
N/OPEN	Detection Alarm	Volt free relay signal contact 24VAC/DC @ 50mA with an integral 25R series resistor Alarm time 5 seconds
N/CLOSED	Detection Alarm	Volt free relay signal contact 24VAC/DC @ 50mA with an integral 25R series resistor Alarm time 5 seconds
A/M	Anti-Mask Detection	Volt free relay signal contact 24VAC/DC @ 50mA with an integral 25R series resistor
Tamper	Front and rear switches	Volt free signal contact 24VAC/DC @ 50mA
LED Indication	1 x Red - Top PIR 1 x Green - Bottom PIR 1 x Amber - Anti-Mask 1 x Blue - Alarm	
Power Input	9 to 15 VDC	
Current	15mA (12V nominal)	
Pulse Count	1 - 2 - 3 - 4	
Temp Compensation	Digital sensitivity adjustment	
Control	Digital microprocessor	
Walk Test	Output test mode with LED indication	
Operating Temp	-20°C to +55° C Conformally coated electronics for increased stability	
Housing	High impact ABS	
Protection Rating	IP65	
Dimensions	145 x 120 x 115 mm	
Weight	280grams NET, 410 grams GROSS	
Mounting Height	Variable from 1.2 metres up to 1.8 metres	
CE Mark		

1

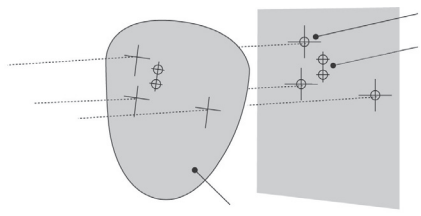

2

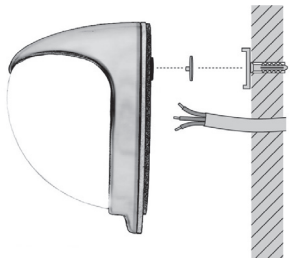

3

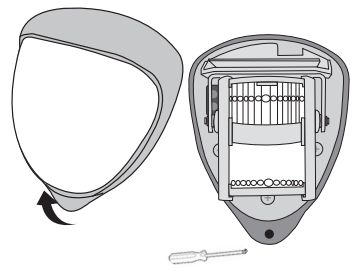

4

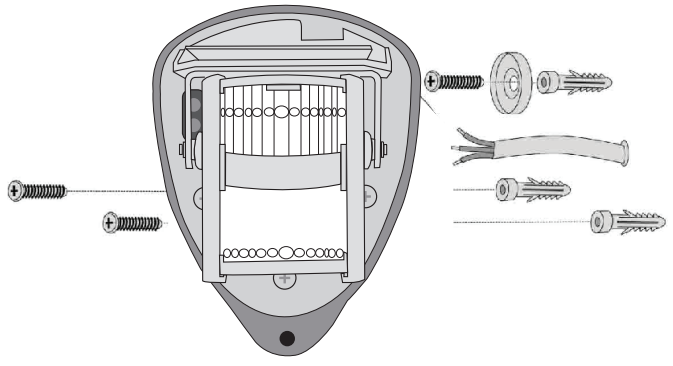

5

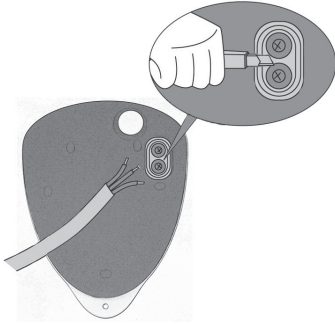

6

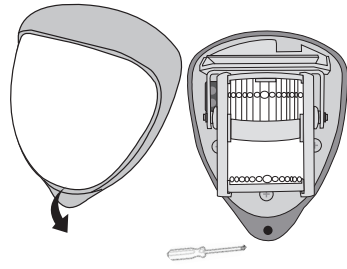

7

⊕ ⊕	⊕ ⊕	⊕ ⊕	⊕ ⊕	⊕ ⊕
A/M	ALARM/NC	TAMPER	ALARM/NO	+ - 9-15 VDC

8

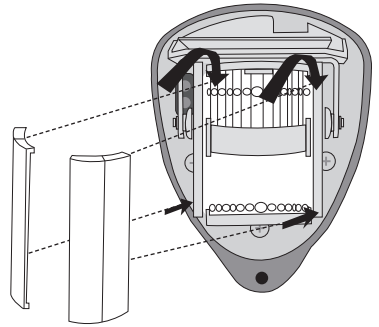

9

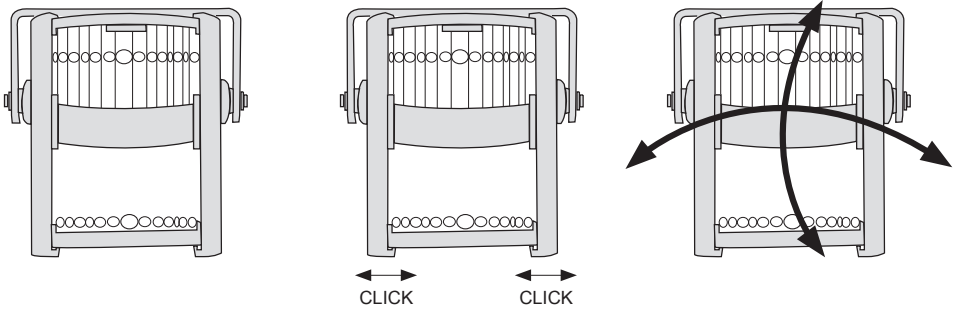

ENGINEER NOTES

www.gjd.co.uk | info@gjd.co.uk | +44 (0) 1706 363 998

Unit 2 Birch Business Park, Whittle Lane, Heywood, Greater Manchester, OL10 2SX, UK