

DATASHEET

HS 805 POE **AISI 316L stainless steel housing** **powered PoE** **(IEEE 802.3af-802.3at compliant)**

- AISI 316L stainless steel housing
- IP67 weatherproof rating
- slide opening system
- powered PoE/PoE+ compliant (802.3af and 802.3at)
- joint with 3rd axis tilt for easier orientation
- easy fastening and positioning
- wide range of accessories



AISI316L stainless steel housing powered PoE

The **HS 805POE** is a cylindrical weatherproof housing, entirely made of AISI 316L stainless steel. This professional housing is designed to simplify installation and maintenance of the most popular PoE network cameras and megapixel network cameras that are compatible with 10/100/Gigabit Ethernet. The "Smart PoE" (*Italian patent*) internal circuit allows to provide power to the camera, the heater and the built-in blower: in this way the housing does not need any additional external power supplies.

The electropolishing treatment increases the corrosion resistance and makes the housing particularly indicated for installations in marine, industrial and chemical environments. It is supplied with a special joint, realized by Global Proof with an exclusive system that allows the third axis tilt: in this way it is possible to mount the housing also in an arched ceiling or on a wall that is not perpendicular to the ground.

The lightweight of this housing allows to mount it also in small pan-tilt systems.

DATASHEET

TECHNICAL DRAWINGS

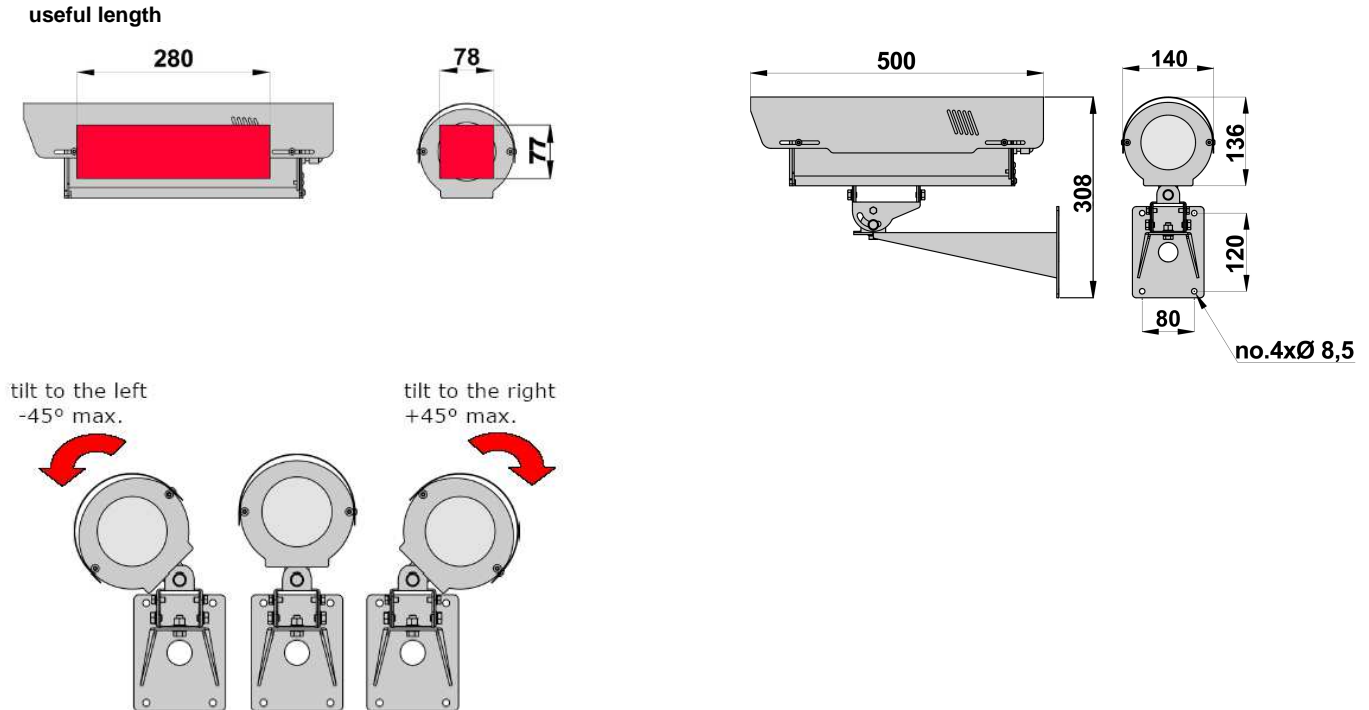

the values are in millimeters

TECHNICAL DATAS

GENERAL

- extractable slide-out body made of stainless steel AISI 316L
- AISI 316L stainless steel sunshield with a wide range of adjustments
- stainless steel A4 bolts and screws
- wall bracket made of stainless steel AISI 316L
- 1xM25 cable gland
- heater
- wide range of accessories
- supplied with instruction manual
- according to RoHS compliance

ELECTRICAL

- heater
 - max. consumption: 5W
 - t on +15°C t off +22°C (+/- 3°C)
- internal ventilation
 - max. consumption: 1W
 - t on +37°C t off +27°C (+/- 3°C)

MECHANICAL

- usable internal space: 78x77mm.(BxH) or Ø 95
- useful length: 260mm
- glass window: Ø 75mm.
- IP67 weatherproof rating
- indoor/outdoor installations
- operating temperature with heater: from -20°C to +60°C (with double heater from -30°C to +60°C)
- weight: 7 Kg. (KIT version with wall bracket included)

ACCESSORIES

- VI805** internal ventilation (pre-assembled)
- RD805** double heater for low temperature (down to -30°C)
- SNF800** adaptor plate for pan mounting

RELATED PRODUCTS

- SP/C** AISI 316L pole adaptor
- SA/C** AISI 316L corner adaptor
- STS800** adaptor plate for ceiling mounting