



CNGE20FX4TX16MSP

10/100/1000 Mbps Managed Ethernet Switch with PoE+

The ComNet CNGE20FX4TX16MSP is a twenty-port managed switch. It provides sixteen 10/100/1000Base-TX copper ports with PoE plus and four 100/1000/2500 Base-FX SFP ports.

Content

- Overview 4
- Basic Settings
 - System 11
 - IPv4 12
 - IPv6 14
 - System Time 16
 - Precision Time Protocol (PTP) 18
- Redundancy
 - Spanning Tree 24
 - ERPS 33
 - MRP (for MS/MP/MT-0802/0804 series) 40
- Management
 - SNMP 45
 - DHCP 50
 - PoE 58
 - Industrial Protocols..... 64
 - UPnP 79
 - NOT USED 80
- L2 Switching
 - Port Management..... 83
 - IGMP / MLD Snooping 93
 - 802.1Q VLAN..... 99
 - Quality of Service..... 106
 - Port Trunk..... 110
 - Voice VLAN..... 182
- Security
 - Storm Control 114
 - 802.1X..... 115
 - Service Control..... 119
 - Access Control List..... 121
 - SSH 128
- Diagnostics

Port Mirroring	130
Remote SPAN (RSPAN)	131
Ping	136
Traceroute	182
Cable Diagnostic	140
Monitoring	
LLDP	141
System Warning.....	143
Data Collection	148
MAC Table	154
Maintenance	
Authorization	156
Firmware Upgrade.....	160
Config Backup	164
Config Restore	165
USB Auto-Load & Auto-Backup	166
Command & Control Node	167
SFTP File Access	172
Command Line Interface	
Connect to CLI via Console Port.....	174
Connect to CLI via Telnet	175
Command Groups.....	182
Hardware Manual	
Hardware Description.....	207
Hardware Installation	211

Overview

CONFIGURATION VIA WEB CONSOLE

1. Open the web browser. We recommend using "Google Chrome".

Note: If the web browser is not supported, the warning message will be showed up.



2. Enter the **IP Address** in the **URL** field to connect to the switch and click "Enter" key.

Note: The default IP Address is "192.168.10.1".

The **Login Page** is displayed.



Configuration Interface

Please enter your username and password.

3. Enter the **Username** and **Password**, and click "**Login**" Button to login to the system.

Note: The default Username and Password is **admin / admin**.

After logging into the system, the "**Overview**" page is displayed. Page format

- For Din rail series models:

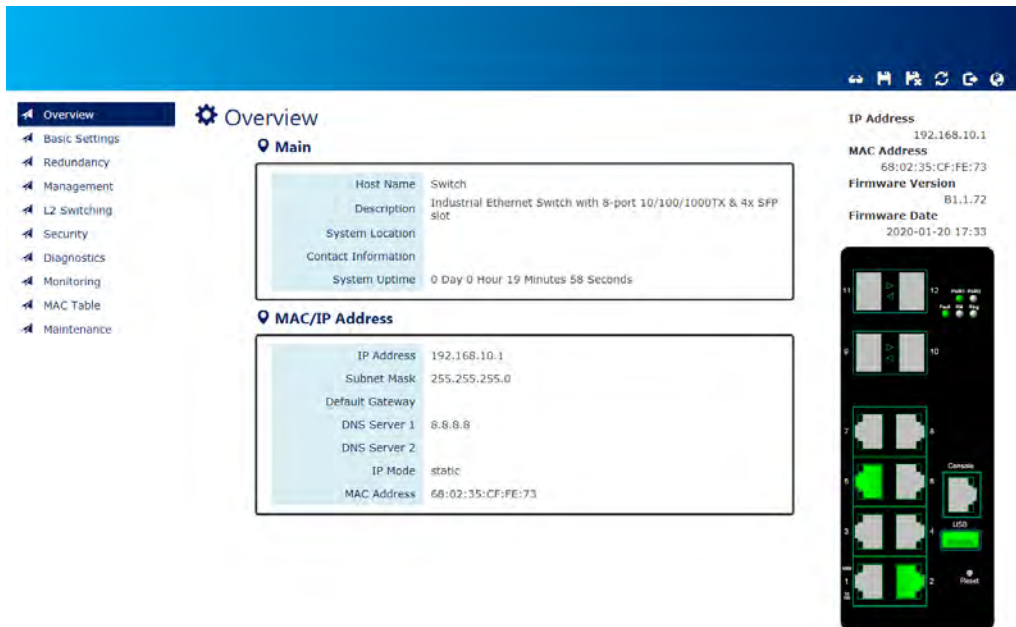

GLOBAL FUNCTIONS

Five global functions are provided in the header field.

1.  [Hide/Show Model Information](#)

When a low-resolution environment is used to configure the system via the web console, the "Model Information" field can be hidden to have a better view.

Show Model Information:

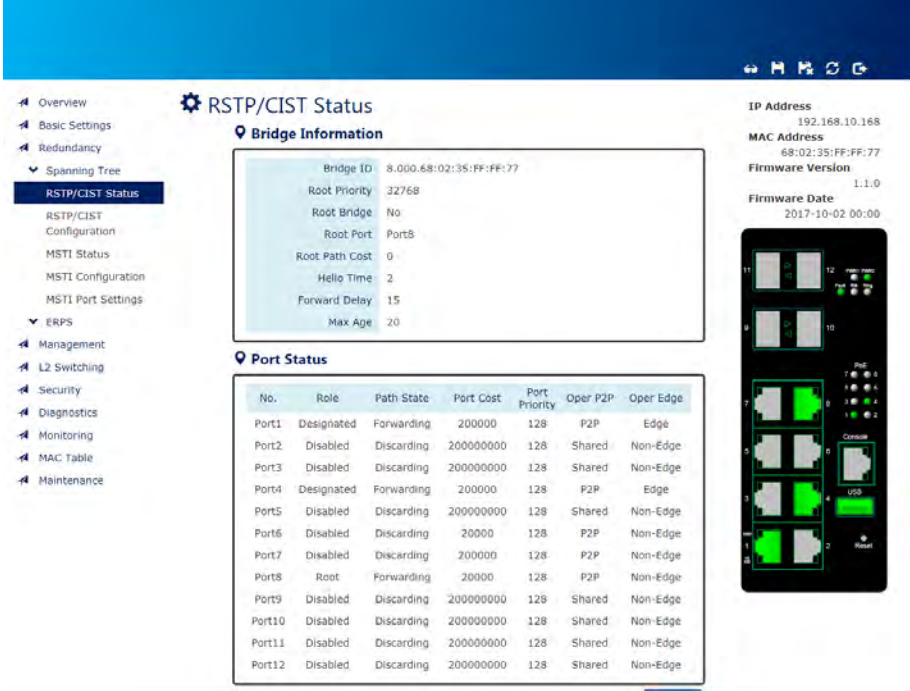

RSTP/CIST Status

Bridge Information

- Bridge ID: 8-000-68-02:35:FF:77
- Root Priority: 32768
- Root Bridge: No
- Root Port: Port8
- Root Path Cost: 0
- Hello Time: 2
- Forward Delay: 15
- Max Age: 20

Port Status

No.	Role	Path State	Port Cost	Port Priority	Oper P2P	Oper Edge
Port1	Designated	Forwarding	200000	128	P2P	Edge
Port2	Disabled	Discarding	200000000	128	Shared	Non-Edge
Port3	Disabled	Discarding	200000000	128	Shared	Non-Edge
Port4	Designated	Forwarding	200000	128	P2P	Edge
Port5	Disabled	Discarding	200000000	128	Shared	Non-Edge
Port6	Disabled	Discarding	200000	128	P2P	Non-Edge
Port7	Disabled	Discarding	200000	128	P2P	Non-Edge
Port8	Root	Forwarding	200000	128	P2P	Non-Edge
Port9	Disabled	Discarding	200000000	128	Shared	Non-Edge
Port10	Disabled	Discarding	200000000	128	Shared	Non-Edge
Port11	Disabled	Discarding	200000000	128	Shared	Non-Edge
Port12	Disabled	Discarding	200000000	128	Shared	Non-Edge

IP Address: 192.168.10.168
MAC Address: 68-02-35:FF:FF:77
Firmware Version: 1.1.0
Firmware Date: 2017-10-02 00:00

Hide Model Information:

RSTP/CIST Status

Bridge Information

Bridge ID	8.000.68:02:35:FF:FF:77
Root Priority	32768
Root Bridge	No
Root Port	Port8
Root Path Cost	0
Hello Time	2
Forward Delay	15
Max Age	20

Port Status

No.	Role	Path State	Port Cost	Port Priority	Oper P2P	Oper Edge
Port1	Designated	Forwarding	200000	128	P2P	Edge
Port2	Disabled	Discarding	200000000	128	Shared	Non-Edge
Port3	Disabled	Discarding	200000000	128	Shared	Non-Edge
Port4	Designated	Forwarding	200000	128	P2P	Edge
Port5	Disabled	Discarding	200000000	128	Shared	Non-Edge
Port6	Disabled	Discarding	20000	128	P2P	Non-Edge
Port7	Disabled	Discarding	200000	128	P2P	Non-Edge
Port8	Root	Forwarding	20000	128	P2P	Non-Edge
Port9	Disabled	Discarding	200000000	128	Shared	Non-Edge
Port10	Disabled	Discarding	200000000	128	Shared	Non-Edge
Port11	Disabled	Discarding	200000000	128	Shared	Non-Edge
Port12	Disabled	Discarding	200000000	128	Shared	Non-Edge

2. Save Configuration

After configuring, click the icon to save the configurations to the "startup-config" file. The configurations are retained in the system until a factory reset default is done.

3. Restore Factory Default

Removes the configurations saved in the system. After restoring factory default, all the settings will be set to default values.

4. [Reboot System](#)

Reboots the device and restarts the system.

5. [System Logout](#)

This option enables you to sign out from the system. Users have to login again if they want to configure the settings.

The system will **auto-logout** after the "timeout" timer expires. The "timeout" timer is configured in the CLI mode by using the "exec-timeout" command.

The maximum value of the timer in the web console is **30 mins**.

6. [Change Language](#)

We support multi-language from firmware version **1.1.72**. The default language is **English** and **Traditional Chinese** is also supported by default. If you need other languages, please contact us.



A USER-FRIENDLY DATA TABLE

A user-friendly data table is provided on the “IPv6 Neighbor Table”, “IGMP Snooping Table”, “VLAN Table”, “LLDP Neighbor Table”, and “MAC Address Table”. The following section details how to use the data table functions to help the users to observe the information easily.

The following example is “MAC Address Table”.

Show entries Search:

VID	MAC Address	Type	Source
VLAN 1	EC:08:6B:06:96:53	Learning	2
VLAN 1	1C:49:7B:6A:F3:41	Learning	5
VLAN 1	1C:1B:0D:66:75:EB	Learning	5
VLAN 1	01:00:5E:7F:FF:FA	Static	2
VLAN 1	40:8D:5C:EA:92:02	Learning	5
VLAN 1	9C:EB:E8:3A:54:E7	Learning	5
VLAN 1	40:8D:5C:EA:8D:C3	Learning	5
VLAN 1	1C:1B:0D:66:F7:F8	Learning	5
VLAN 1	FC:3F:DB:53:19:8E	Learning	5
VLAN 1	A4:02:B9:80:7D:66	Learning	5

Showing 1 to 10 of 10 entries

Auto Refresh

Refresh Rate: seconds 

- Show entries

Users will be able to select a value to display the number of entries in one page. The following values can be selected - “10”, “25”, “50”, and “100” selections. By default, “10” is selected.

- Search:

The search option enables you to search a key word in the data. It will search all the columns and identify the data rows that match the search criteria.

- Showing 1 to 10 of 31 entries

It displays the total number of entries and the current entry number.

-  and 

This option orders the field from **smaller to larger** or from **larger to smaller**.

-

Changes to “First”, “Previous”, “Next”, or “Last” page.

In addition to the above functions, “**Refresh**” and “**Auto Refresh**” function are available for all status page including “**IPv6 Neighbor Table**”, “**RSTP Port Status**”, “**DHCP Leased Table**”, “**Port Status**”, “**IGMP Snooping Table**”, “**VLAN Table**”, “**Trunking Status**”, “**LLDP Neighbor Table**”, and “**MAC Address Table**”.

- Auto Refresh

Selecting this checkbox enables the “Auto Refresh” function and deselecting the checkbox disables the “Auto Refresh” function.

- Refresh Rate: seconds 

The Refresh Rate option is a **global** configurable variable. When the Auto Refresh option is enabled, the status will refresh automatically based on the Refresh Rate interval.

The range of the Refresh Rate is **from 5 to 300** second(s).

The default Refresh Rate is **5** seconds.

- (Refresh Button)

You can click the “**Refresh**” button to manually refresh the status.

System Information

CONFIGURE SYSTEM INFORMATION

System Information

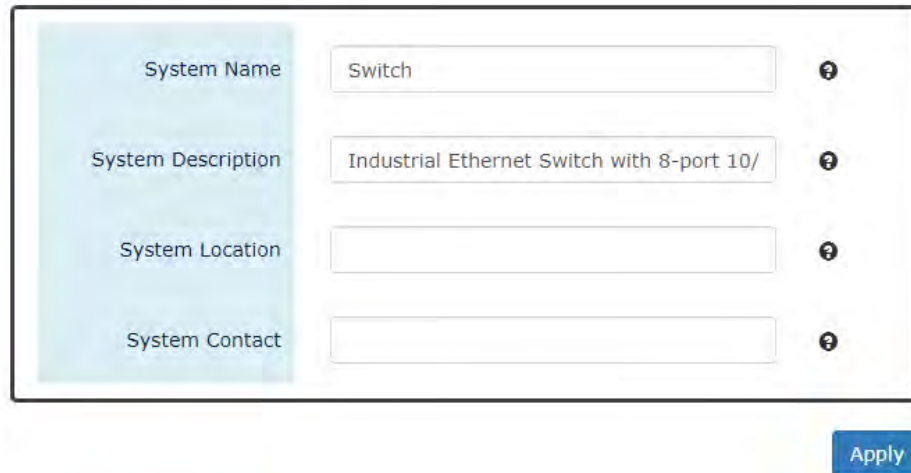

For more information, hover the mouse over the  icon in the system.

- Host Name**

It is useful to identify the difference between the switches, for example: CoreSwitch01.
The **max. length** for the Host Name is **32 characters**.
Note: #, \, ', ", ? are **invalid** characters.
- System Description**

The System Description is default defined by the system.
It contains the copper port number, fiber port number, and PoE information (if supported).
The **max. length** for the System Description is **68 characters**.
Note: #, \, ', ", ? are **invalid** characters.
- Switch Location**

It is useful to find the location of the switches, for example: Area01.
The **max. length** for the Switch Location is **32 characters**.
Note: #, \, ', ", ? are **invalid** characters.
- Contact Information**

Records the information of the person responsible for this device and also the contact details.
Note: #, \, ', ", ? are **invalid** characters.
-  (Apply Button)

After configuring above fields, click "**Apply**" button to make the changes effective.

IPv4

Internet Protocol Version 4 (IPv4) is the fourth version of the Internet Protocol. It is used on the packet-switched networks and with connectionless communication. IPv4 has four bytes (32 bits) address and the address space is limited to 4,294,967,296 (2^{32}) unique addresses. On the local area network (LAN), the "Private Network" is used. It starts from **192.168.0.0** and the address space contains 65,025 (2^{16}) IP addresses. The frames can only be sent to the host in the same subnet. For example, the default IP Address of the switch is "192.168.10.1". When the users want to connect to the web console of the switch, an IP address from "192.168.10.2" to "192.168.10.254" must be assigned to the host.

CONFIGURE IPv4 INFORMATION



IPv4 Mode Static DHCP Client

IP Address

Subnet Mask

Default Gateway

DNS Server 1

DNS Server 2

[Apply](#)

- IPv4 Mode**

There are 2 ways to configure IPv4 address - one is to configure a **static** IP address manually and another one is to get an IP address by **DHCP**.
If the IPv4 mode is "**DHCP Client**", IPv4 information fields will be set to "**Disabled**".
- IP Address**

Assigns a unique static IP Address in the subnet to access the system.
The default IP Address is "**192.168.10.1**".
- Subnet Mask**

Defines the type of network, to which this device is connected to.
The default Subnet Mask is "**255.255.255.0**".
- Default Gateway**

The IP address of the router used to connect a LAN to a WAN.

- [DNS Server 1 & 2](#)

Specifies the IP address of the DNS Server so that the users can connect to another device based on the **URL** instead of the IP address.

The default DNS Server is "**8.8.8.8**". It is provided by Google.

-  (Apply Button)

After configuring above fields, click "**Apply**" button to make the changes effective.

IPv6

Internet Protocol Version 6 (IPv6) is a solution to deal with the address space limitation of IPv4 and it is the most recent version of Internet Protocol. It is intended to replace IPv4. IPv6 is a **Layer 3** (Internet Layer) protocol, which is used on the packet-switched networks and with connectionless communication. There are 16 bytes (128 bits) for an IPv6 address and the address space is up to 2^{128} unique addresses. The IPv6 address is usually represented in hexadecimal digits, 8 groups of 4 digits, and each group is separated by a ":" (**colon**). For example, the DNS server address in IPv6 is "2001:4860:4860:0000:0000:0000:8888".

CONFIGURE IPv6 INFORMATION

IPv6 Settings

IPv6 Mode	<input checked="" type="radio"/> Enable <input type="radio"/> Disable
Default Address	fe80::6a02:35ff:fe66:701f / 64
Default Gateway	<input type="text"/>

IPv6 Addresses

IPv6 Address	/	Prefix	+
<input type="text"/>	/	<input type="text"/>	×

Apply

- [IPv6 Mode](#)
 "Enable" or "Disable" IPv6. When the IPv6 Mode is enabled, other devices can connect to this unit.
 The default IPv6 Mode is "Enable".
- [Default Address](#)
 This is the Default IPv6 Address for this device. It is a **Link-Local** address and is automatically generated from the **MAC Address** of the device.
- [Default Gateway](#)
 This is the **Default IPv6 Gateway** for this device. The IPv6 address of the router used to connect a LAN to a WAN when the devices are using IPv6 for communication.
- [IPv6 Addresses](#)
 Enables the users to define other IPv6 addresses for this device.
 The IPv6 address contains 2 section - **IPv6 address** and **prefix**. The default Prefix is **64-bit**.

+: Click the **plus icon** to add a IPv6 Address row.

X: Click the **remove icon** to delete the IPv6 Address row.

- **Apply** (Apply Button)

After configuring above fields, click "**Apply**" button to make the changes effective.

IPv6 NEIGHBOR TABLE

IPv6 Neighbor Table

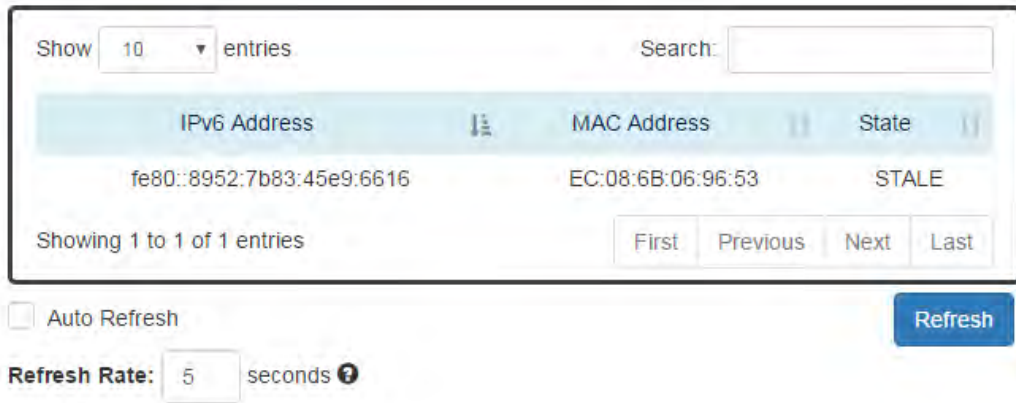

IPv6 Address	MAC Address	State
fe80::8952:7b83:45e9:6616	EC:08:6B:06:96:53	STALE

Showing 1 to 1 of 1 entries

First Previous Next Last

Auto Refresh Refresh

Refresh Rate: seconds 

- **IPv6 Address**
This field displays the IPv6 address of the neighbor.
- **MAC Address**
This field displays the MAC address of the neighbor.
- **State**
The connection state can be "DELAY", "REACHABLE", "STALE", "FAILED", or "PROBE".

System Time

The **System Time** represents the date and time. The system uptime defines the passing time after the system boots up. There is no battery on the switch and hence the system time cannot be saved in the system. Users can configure the time zone and system time manually by synchronizing the time with the browser or by enabling the “**NTP**” service to get the time from a **NTP Server**.

NTP

Network Time Protocol (NTP) is a clock synchronization protocol, which is used to synchronize the system time with the NTP server. NTP is one of the oldest Internet Protocols in use from 1985 until now. It works based on a client-server model, but it can also be used in peer-to-peer relationships. The NTP application on the switch follows the client-server model and the switch plays a role in the NTP Client.

CONFIGURE SYSTEM TIME INFORMATION

System Time

System Time Information

Current Time ⓘ	1970/01/01 04:15:41.352115737
System Uptime	0 Day 4 Hours 14 Minutes 40 Seconds

NTP Settings

NTP Mode	<input type="radio"/> Enable <input checked="" type="radio"/> Disable
NTP Server 1	<input type="text" value="2.pool.ntp.org"/>
NTP Server 2	<input type="text" value="2.pool.ntp.org"/>
NTP Sync Time ⓘ	<input type="text" value="1"/> <input type="text" value="Hour"/>

Manual Time Settings

Time Zone	<input type="text" value="Europe"/> <input type="text" value="London"/>
Date Selector	<input type="text" value="1970/01/01"/>
Time Settings	<input type="text" value="04"/> : <input type="text" value="14"/> : <input type="text" value="40"/>
Sync with Browser	<input type="checkbox"/> 2021/12/21 14:23:11

Apply

System Time Information

- Current Time: The current date time of the system.
Note: Time format: Year/Month/Day 24HR:Min:Sec.NanoSec
- System Uptime: The system boot up duration.
- **NTP Settings**
 - NTP Mode
"Enable" or "Disable" NTP Service. If NTP Mode is enabled, the system will sync time with NTP Server on an hourly basis.
 - NTP Server 1 & 2
This field displays the URL or the IP address of the host that provides the NTP Service. There are 2 server configurations supported.
 - NTP Sync Time
The system synchronize interval with the NTP server. Time scale can be **minute, hour, day, week** and **month**. The value range is **from 1 to 60**.
- **Manual Time Settings**
 - Time Zone
Select the Time Zone to define the local time offset from GMT.
 - Date Selector
Select the system date manually. The format is "**year/month/day**".
 - Time Setting
Define the system time manually. The format is "**hour:minute:second**".
 - Sync with Browser
Select the checkbox to synchronize the system time with the **browser time**.
-  (Apply Button)
After configuring above fields, click "**Apply**" button to make the changes effective.

Precision Time Protocol (PTP)

The **Precision Time Protocol (PTP)** is used to synchronize clocks and it is more accurate than NTP. PTP is majorly employed to synchronize the network devices that require precise timing like financial transactions. Synchronization and management of a PTP network is implemented by the exchange of messages across the communications devices.

PTP is working by a **Master** and **Slave** structure. There are three types of PTP clocks – **Ordinary Clock**, **Boundary Clock**, and **Transparent Clock** and currently we support **Ordinary Clock** and **Transparent Clock** on the **L2**, **Router**, and **L3** switches, and **Boundary Clock** on the **Router** and **L3** switches. If the switch is an Ordinary Clock, it can be configured as role Master or Slave. For the Boundary Clock and Transparent Clock, they can be both Master and Slave at the same time to synchronize with the Master and forward to Slaves.

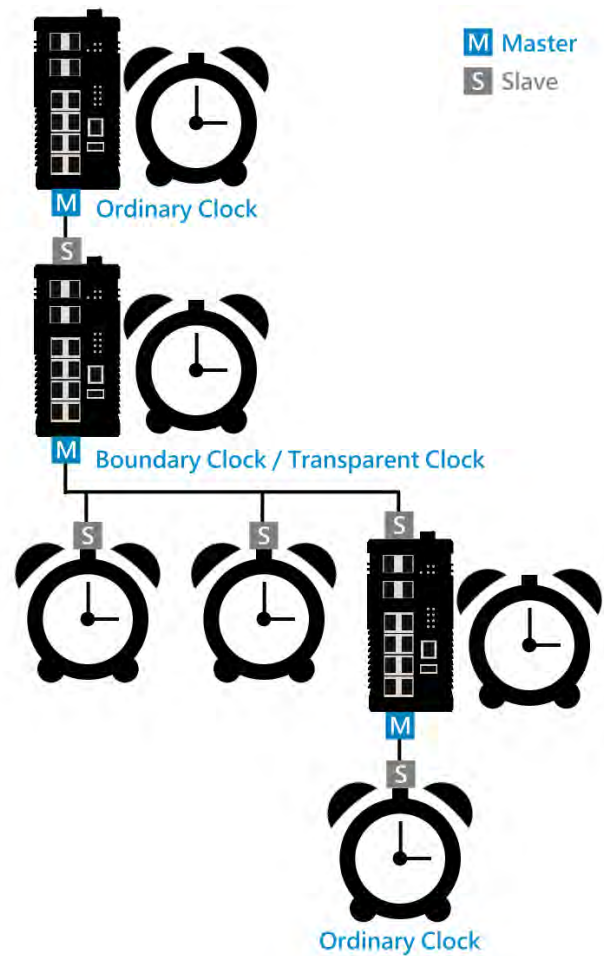

CONFIGURE PTP BASIC INFORMATION – ORDINARY CLOCK

⚙️ PTP Configuration

📍 Basic Settings

PTP Status	<input checked="" type="radio"/> Enable	<input type="radio"/> Disable
PTP Mode	<input checked="" type="radio"/> Master	<input type="radio"/> Slave
Domain ID	<input type="text" value="0"/> ⓘ	

For more information, hover the mouse over the ⓘ icon in the system.

- [PTP Status](#)

"Enable" or "Disable" the PTP protocol.

Note: The **PTP Slave** and **NTP Client** are mutually incompatible, if users want to enable PTP mode with role Slave, please make sure the NTP Client is disabled.

- [PTP Mode](#)

There are 2 modes of PTP that supported on the switch – **Master** and **Slave**. Masters provide clock time to Slaves and Slaves follow and adjust the clock time.

- **Domain ID**

The ID is the identifier of the PTP network. Only the nodes with the same Domain ID synchronize the time in the network.

The default value of **Domain ID** is **0**

The range of **Domain ID** is **from 0 to 127**

CONFIGURE PTP ADVANCED SETTINGS

Advanced Settings

Priority1	<input type="text" value="128"/>	?
Priority2	<input type="text" value="128"/>	?
Announce Interval	<input type="text" value="1"/>	▼
Announce Timeout	<input type="text" value="6"/>	?
Sync Interval	<input type="text" value="0"/>	▼
Period	<input type="text" value="0"/>	?

[Apply](#)

For more information, hover the mouse over the ? icon in the system.

- **Priority 1**

The Priority is used to decide the Best Master when there are several Master nodes in the PTP network. If there are 2 or more Masters with the same **Priority 1**, the system will refer to the **Priority 2**.

The default value of **Priority 1** is **128**

The range of **Priority 1** is **from 0 to 248**

Note: the lower the value the higher the priority

- **Priority 2**

The Priority is used to decide the Best Master when there are several Master nodes with the same **Priority 1** in the PTP network. If there are 2 or more Masters with the same **Priority 2**, the system will refer to the **Clock Identity (MAC Address)**.

The default value of **Priority 1** is **128**

The range of **Priority 1** is **from 0 to 248**

Note: the lower the value the higher the priority

- **Announce Interval**

The Announce Interval is the period to send Announce Message.

The range of **Announce Interval** is **from -1 to 7**

- **Announce Timeout**

The **Announce Timeout** is the timer for announcing timeout message.

The default value of **Announce Timeout** is **6**

The range of Announce Timeout is from 2 to 255

- Sync Interval

The Sync Interval is the period to send Sync Message.

The range of Sync Interval is from -7 to 7

The mapping for Announce Interval and Sync Interval to **second(s)** is as following table:

Interval	0	1	2	3	4	5	6	7
Seconds	1s	2s	4s	8s	16s	32s	64s	128s
Interval		-1	-2	-3	-4	-5	-6	-7
Seconds		512ms	256ms	128ms	64ms	32ms	16ms	8ms

- Period

The Period is a timeout period. The Slave node will wait n (Period Value) times that announce receipt timeout before resetting.

The default value of Period is 0

The range of Period is from 0 to 20

-  (Apply Button)

After configuring above fields, click "**Apply**" button to make the changes effective.

PTP STATUS – MASTER

PTP Status

PTP device type	MasterOnly Clock
Clock Domain	0
Clock ID	680235fffef1c441
Best master ID	680235fffef1c441
Priority1	128
Priority2	128
Class	13

- PTP Device Type

This field is the type/role of switch that in a PTP network. The switch can be “**Master Only**” or “**Slave Only**” currently because we only support **Ordinary Clock** now.

- Clock Domain

This field shows the Domain ID that the system is in now.

- Clock ID

This field is the identity of the switch in the PTP network. The Clock Identity is configured to the MAC Address of the switch by default.

- [Best Master ID](#)
The [Best Master ID](#) is the [Clock Identity](#) of the Best Master in a PTP network. If there are several Master in the PTP network, users can understand which one is the Best Master through this field.
- [Priority 1](#)
This field is the value of **Priority 1** that is configured.
- [Priority 2](#)
This field is the value of **Priority 2** that is configured.
- [Class](#)
The Class field is usually named **colckClass**. The values of PTP clock classes are based on the traditional quality levels from SSM/ESMC.

PTP STATUS – SLAVE

PTP Status

PTP device type	SlaveOnly Clock
Clock Domain	0
Clock ID	680235ffef1c441

- [PTP Device Type](#)
This field is the type/role of switch that in a PTP network. The switch can be “**Master Only**” or “**Slave Only**” currently because we only support **Ordinary Clock** now.
- [Clock Domain](#)
This field shows the Domain ID that the system is in now.
- [Clock ID](#)
This field is the identity of the switch in the PTP network. The Clock Identity is configured to the MAC Address of the switch by default.

CONFIGURE PTP BASIC INFORMATION – TRANSPARENT CLOCK

PTP Hardware Configuration

Port	Mode	Status
1	None	Disable
2	None	Disable
3	None	Disable
4	None	Disable
5	None	Disable
6	None	Disable
7	None	Disable
8	None	Disable
9	None	Disable
10	None	Disable
11	None	Disable
12	None	Disable

Apply

Known Limitations:

The Transparent Clock is only supported on the following conditions:

- **VLAN untagged mode**
- **L2 management switches**
- **Copper ports and 1G SFP Slots**
- **One-step Mode**
- **End-to-End delay mechanism**
- **Port**
Port 1 to Port N, where N is based on the total port number.
- **Mode**

Select Transparent Mode or Normal Mode (None) on the designated port.

- [Status](#)
“Enable” or “Disable” selected mode on the designated port.
-  (Apply Button)

After configuring above fields, click "**Apply**" button to make the changes effective.

Spanning Tree

The **Spanning-Tree Protocol** is a standard protocol that is defined in **IEEE 802.1D**. It is used to build a **logical loop-free** topology for layer-2 Networks. The basic function of the protocol is to prevent loops and broadcast flooding around the switches. STP allows spare links in the network design to provide **backup paths** when the active link fails and requires a **convergence time** of **30-50 seconds** to recover the topology when the topology is changed. This prompted the use of **Rapid Spanning-Tree Protocol** as it provides a faster convergence when the topology is changed.





RSTP was introduced by IEEE as **802.1w**. It can respond within **3 x "Hello Time"** when a topology is changed. The "Hello Time" is a configurable value and it is very important for RSTP. The default RSTP value is **2 seconds** and typically, the convergence time for RSTP is **under 6 seconds**. RSTP is much faster than STP. RSTP should be used instead of STP.

The **Multiple Spanning-Tree Protocol** defined in the **IEEE 802.1s** is an extension to RSTP for Virtual LANs. MSTP provides a better alternate path than STP/RSTP for different VLANs. It can make a group of VLANs more systemized in the topology.

CONFIGURE RSTP/CIST BASIC INFORMATION

RSTP/CIST Configuration

Bridge Settings

Mode	RSTP	
Priority	32768	
Hello Time	2	
Forward Delay	15	
Max Age	20	

For more information, hover the mouse over the  icon in the system.

- [System Time Information](#)

RSTP: Enable STP and run "RSTP" for redundancy.

MSTP: Enable STP and run "MSTP" for redundancy.

Disable: Disable STP. Users have to enable another protocol to prevent from loop.

- [Root Priority](#)

It is used to define the "**Root Bridge**". The bridge with the **lowest Root Priority** is the "Root Bridge". If all the bridges are set to the same Root Priority value, the system will select the Root Bridge based on the **MAC Addresses**.

The range of Root Priority is **from 0 to 61440 (multiple of 4096)**.

The default Root Priority is **32768**.

- **Hello Time**

It is very important and used to determine the interval to send BPDU (management frame) to check the RSTP topology and status.

The range of Hello Time is **from 1 to 10** second(s).

The default Hello Time is **2** seconds.

- **Forward Delay**

A delay/timer is used to determine when to change the **Path State** from Learning/Listening to Forwarding.

The range of Forward Delay is **from 4 to 30** seconds.

The default Forward Delay is **15** seconds.

- **Maximum Age**

A timer that is used to wait for the Hello BPDU from the Root Bridge. If this device receives the BPDU before the timer expires, the timer will be reset. Else, the device will send the topology changed BPDU to notify other devices.

The range of Maximum Age is **from 6 to 40** seconds.

The default Maximum Age is **20** seconds

The relationship between "Hello Time", "Forward Delay", and "Maximum Age" is:

$$2 \times (\text{Forward Delay} - 1 \text{ sec}) \geq \text{Max Age} \geq 2 \times (\text{Hello Time} + 1 \text{ sec})$$

CONFIGURE RSTP PORT INFORMATION

Port Settings

Port	Port Cost 	Port Priority	Admin P2P	Edge	Admin STP
1	0	128	Shared	Auto	Enable
2	0	128	Shared	Auto	Enable
3	0	128	Shared	Auto	Enable
4	0	128	Shared	Auto	Enable
5	0	128	Shared	Auto	Enable
6	0	128	Shared	Auto	Enable
7	0	128	Shared	Auto	Enable
8	0	128	Shared	Auto	Enable
9	0	128	Shared	Auto	Enable
10	0	128	Shared	Auto	Enable
11	0	128	Shared	Auto	Enable
12	0	128	Shared	Auto	Enable

Apply

For more information, hover the mouse over the  icon in the system.

- Port**
Port 1 to Port N, where N is based on the total port number.
- Path Cost**
The cost from the current node to another device.
The range of Path Cost is **from 0 to 200000000**.
The default Path Cost is **0**. This implies that the Path Cost is decided by the system.
- Port Priority**
Used to decide the port to be blocked in the Ring topology.
The range of Root Priority is **from 0 to 240** and are in **multiple of 16**.
The default Root Priority is **128**.

- [Admin P2P](#)
The Admin P2P is the link-type for each port.
P2P: It is a full-duplex link.
Shared: It is a half-duplex link.
- [Edge](#)
A port that can connect to a **non-STP device** is called an Edge port. Users can manually fix a port to non-Edge or Edge.
Auto: The system **automatically** identifies an Edge or Non-Edge.
Edge: The port is forced to be an Edge port. An edge port will directly be transitioned to the "**Forwarding**" state and is not required to wait for the "Forward Delay". If a port is directly connected to a non-STP device, users can manually set it to "Edge" and enable it to transmit faster.
Non-Edge: The port is forced to be a Non-Edge port. This implies that the port will go through Learning/Listening to Forwarding state even though it is connected to an end device or not.
- [Admin STP](#)
"Enable" or "Disable" the Spanning-tree protocol that is running on the specific port.
-  (Apply Button)
After configuring above fields, click "**Apply**" button to make the changes effective.

RSTP/CIST STATUS

RSTP/CIST Status

Bridge Information

Bridge ID	8.000.68:02:35:B7:89:05
Priority	32768
Root Bridge	Yes
Root Port	none
Root Path Cost	0
Hello Time	2
Forward Delay	15
Max Age	20

- [Bridge ID](#)
This field shows the **unique** identity of this node when it is part of a network. It contains **8 bytes** - the first 2 bytes are for **Bridge Priority** (configurable) and the remaining 6 bytes are for the **MAC Address** (unique).
- [Root Bridge](#)

It is elected from the switches in the STP topology via several **STP messages (BPDU)**. The Root Bridge is the node with the **lowest Root Priority**. If all of the nodes are with the same Root Priority, the Root Bridge will be selected based on their **MAC Addresses**.

- [Root Priority](#)

It is used to define the "**Root Bridge**". The bridge with the **lowest Root Priority** is the "Root Bridge". If all bridges are set to the same Root Priority value, the system will select the Root Bridge based on the **MAC Addresses**.

- [Root Port](#)

It is the port that is **connected to the Root Bridge** and with the **lowest cost**. If the Root Port shows "**none**", it implies this node is the Root Bridge.

- [Root Path Cost](#)

It is the cost from the current node to the Root Bridge.

- [Hello Time](#)

It is used to determine the interval to send BPDU (management frame) to check the RSTP topology and status.

- [Forward Delay](#)

It is used to determine when to change the **Path State** from Learning/Listening to Forwarding.

- [Max Age](#)

It is used during waiting for Hello BPDU from the Root Bridge.

Port Status

Port	Role	Port Status	Port Cost	Port Priority	Oper P2P	Oper Edge
1	Disabled	Discarding	200000000	128	Shared	Non-Edge
2	Designated	Forwarding	20000	128	P2P	Non-Edge
3	Disabled	Discarding	200000000	128	Shared	Non-Edge
4	Disabled	Discarding	200000000	128	Shared	Non-Edge
5	Disabled	Discarding	200000000	128	Shared	Non-Edge
6	Disabled	Discarding	200000000	128	Shared	Non-Edge
7	Disabled	Discarding	200000000	128	Shared	Non-Edge
8	Disabled	Discarding	200000000	128	Shared	Non-Edge
9	Disabled	Discarding	200000000	128	Shared	Non-Edge
10	Disabled	Discarding	200000000	128	Shared	Non-Edge
11	Disabled	Discarding	200000000	128	Shared	Non-Edge
12	Disabled	Discarding	200000000	128	Shared	Non-Edge

Auto Refresh

[Refresh](#)

- [Port](#)

Port 1 to Port N, N is based on the total port number.

- [Role](#)

This field shows the role of the STP port.

Root: This is the root port, which is connected to the Root Bridge with the lowest cost.

Designated: This is the designated port, which can send the best BPDU on the segment to other connected nodes.

Alternate: This is the alternate port, which is blocked. This port can still receive useful BPDU **from another bridge**. When it receives a useful BPDU, it will help to forward it on the segment.

Backup: This is the backup port, which is blocked. It corresponds with “Alternate Port” to the blocking state. This port also receives useful BPDU, but the BPDU is **from the same bridge**. When it receives a useful BPDU, it will help to forward it on the segment.

Disabled: The port is not linked up.

- **Path State**

This field shows the path state of this STP port.

Discarding: The port state can be “Disabled”, “Blocking”, or “Listening”. The incoming frames are dropped and learning MAC addresses are stopped.

Learning: The port is learning MAC addresses, but the incoming frames are dropped.

Forwarding: The port in the forwarding state forwards the incoming frames based on the learned MAC address table.

- **Port Cost**

This is the cost from the port to the Root Bridge. Spanning-tree Protocol assumes the path cost is determined by the **access speeds of the links**. The **default RSTP path cost** is shown in the following table:

Speed	RSTP Path Cost	Speed	RSTP Path Cost
4 Mbps	5,000,000	1000 Mbps (1Gbps)	20,000
10 Mbps	2,000,000	2000 Mbps (2 Gbps)	10,000
16 Mbps	1,250,000	10000 Mbps (10 Gbps)	2,000
100 Mbps	200,000		

- **Port Priority**

The Port Priority is used to determine the Root Port on a non-root bridge. The port with the lowest Port Priority value gets the higher priority.

- **Oper. P2P**

This field shows the link-type of the STP port. P2P means “**point-to-point**” and Shared means “**point-to-multiple**”.

- **Oper. Edge**

This field shows the edge state of this STP port.

CONFIGURE MSTI INFORMATION

⚙️ MSTI Configuration

📍 Basic Settings

Region Name	<input type="text" value="680235b78905"/>	?
Revision Number	<input type="text" value="0"/>	?

📍 Instance Settings

Instance	Included VLAN ?	Priority
1.	<input type="text"/>	32768 ▼
2.	<input type="text"/>	32768 ▼
3.	<input type="text"/>	32768 ▼
4.	<input type="text"/>	32768 ▼
5.	<input type="text"/>	32768 ▼
6.	<input type="text"/>	32768 ▼
7.	<input type="text"/>	32768 ▼
8.	<input type="text"/>	32768 ▼
9.	<input type="text"/>	32768 ▼
10.	<input type="text"/>	32768 ▼
11.	<input type="text"/>	32768 ▼
12.	<input type="text"/>	32768 ▼
13.	<input type="text"/>	32768 ▼
14.	<input type="text"/>	32768 ▼
15.	<input type="text"/>	32768 ▼

Apply

For more information, hover the mouse over the ? icon in the system.

- **Basic Settings**

- **Region Name**

The Region Name is the name of the MST Region. The switches in the same MST Region must be set to the same Region Name.

The **max. length** for the Region Name is **32 characters**.

Note: #, \, ', ", ? are **invalid** characters.

- **Revision Number**

The Revision Number is the level of the MST Revision. The switches in the same MST Region must be set to the same Revision Number.

The range of the Revision Number is **from 0 to 65535**.

The default Revision Number is **0**.

- **Instance Settings**

- **Instance**

The Instance is from 1 to 15.

- **Included VLAN**

The configured VLANs are involved in the specific Instance.

The format is: 10, 20, 30.... "Comma" is used to separate VLAN IDs.

- **Priority**

The priority is used to define the "Root Bridge" that is used to communicate with other MSTI Region.

The range of the Root Priority is **from 0 to 61440 (multiple of 4096)**.

The default Root Priority is **32768**.

- **Apply** (Apply Button)

After configuring above fields, click "**Apply**" button to make the changes effective.

CONFIGURE MSTI PORT INFORMATION

MSTI Port Settings

Instance 1

Instance 1

Port	Port Cost 	Port Priority
1	0	128
2	0	128
3	0	128
4	0	128
5	0	128
6	0	128
7	0	128
8	0	128
9	0	128
10	0	128
11	0	128
12	0	128

Apply

For more information, hover the mouse over the  icon in the system.

- [Instance Selector](#)
Select the instance to configure the ports. The Instance No. is from 1 to 15.
- [Port](#)
Port1 to PortN, where N is based on the total port number.
- [Path Cost](#)
The Path Cost is the cost from the current node to another device.
The range of the Path Cost is **from 0 to 200000000**.
The default Path Cost is **0**. This implies that the Path Cost is decided by the system.
- [Port Priority](#)
This is used to identify the port to be blocked in the Ring topology.
The range of the Root Priority is **from 0 to 240** and is in **multiples of 16**.
The default Root Priority is **128**.
-  (Apply Button)
After configuring above fields, click "**Apply**" button to make the changes effective.

ERPS

Ethernet Ring Protection Switching (ERPS) applies the protection switching mechanism for Ethernet traffic in a ring topology. This mechanism is defined in **ITU-T G8032**. You can have a protection switching and avoid the possible loops in a network by implementing the ERPS function. This is done by blocking the flow of traffic to the **Ring Protection Link (RPL)** there by protecting the entire Ethernet ring.

When an ERPS is implemented in a ring topology, only one switch is allocated as the **owner**. This switch is in charge of blocking the traffic in the RPL to avoid loops. The switch adjacent to the RPL owner is called the **RPL neighbor** node and it is responsible for blocking the end of the RPL during normal condition. The participating switches that are adjacent to the RPL owner or neighbor in a ring are called the members or RPL next-neighbor nodes. The primary function of these switches is to forward the received traffic.

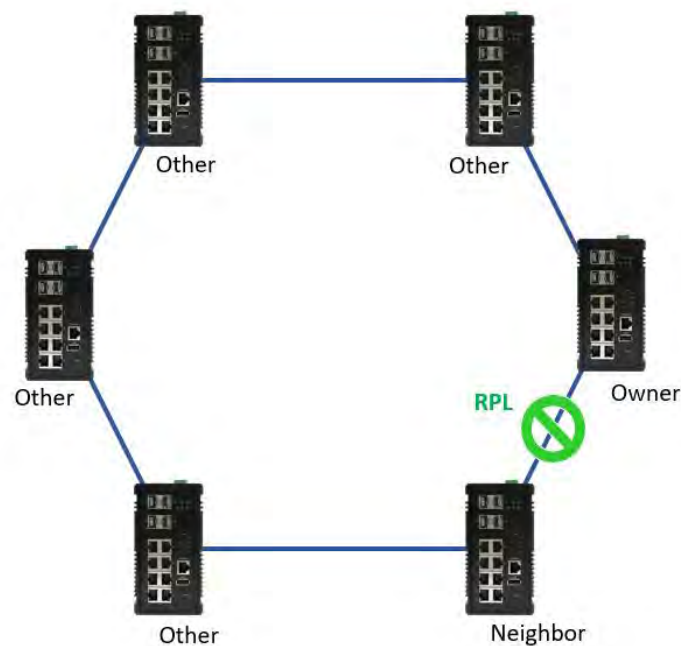

The benefit of the ERPS ring protection switching architecture are:

- ◆ Protection switching on Ethernet layer
- ◆ Preventing loop by blocking mechanism
- ◆ VLAN based protection
- ◆ **Sub-50msec** protection switching
- ◆ Support administration command
- ◆ **250 switches** and links in singled ring tested

To make sure that a ring is up and loop-free, **Ring Automatic Protection Switching** message is sent regularly as control messages by nodes on the ring. The RPL owner identifies a signal failure (SF) in a ring when the RPL owner misses the poll packets or reads from the fault detection packets. When the fault is identified, the RPL owner unblocks the ring protection link (RPL) and permits the protected VLAN traffic through.

ERPS, similar to STP, provides a **loop-free** network by using polling packets to detect faults. If a fault occurs, ERPS restores itself by sending traffic over a protected reverse path rather than making a calculation to identify the forwarding path. The fault detection mechanism in the ERPS enables the ERPS to join in **less than 50 milliseconds** and recovers quickly to forward traffic. In a real test case, the protection switching time is 15ms in 250 devices single ring topology.

In the new ERPS version, G.8032 v2, it supports multiple ring or ladder topology. Rings can conjoin by one or more interconnection nodes. The major ring controls a full physical ring. Sub ring does not constitute a closed ring. It is connected to a major ring at the interconnection nodes.

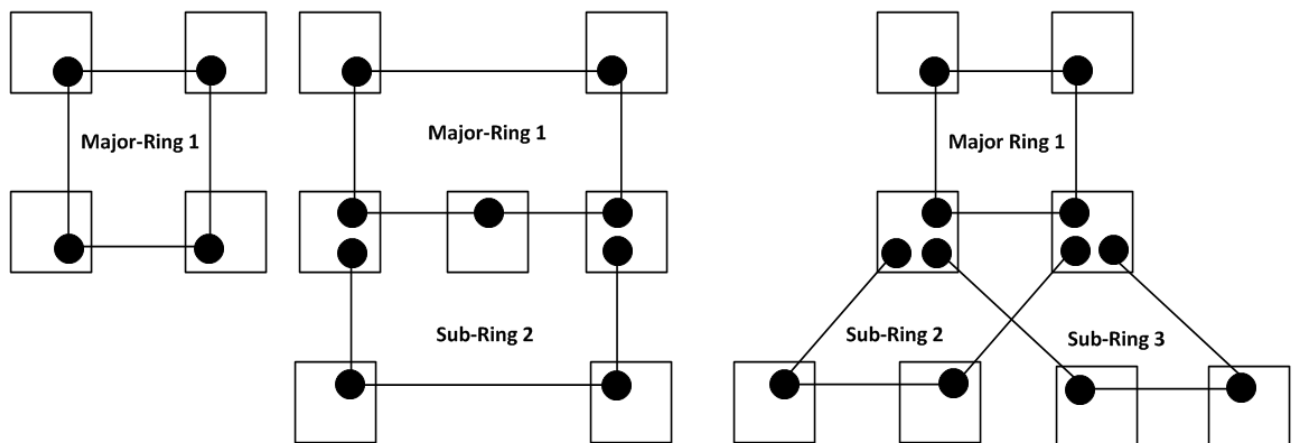

Using major ring and sub ring can design multiple ring or ladder topology. With these topologies, ERPS can append to variance application with different level of ring network. For example, core ring and branch ring architecture has application in campus and the area with central control node. Ladder topology has lots of case for tunnel and train application. The benefit of small ring is less effect nodes if ring caused of recovery.

CONFIGURE ERPS INFORMATION

ERPS Configuration

Ring 1

Basic Settings

ERPS Status	<input type="radio"/> Enable <input checked="" type="radio"/> Disable
Ring Type	<input checked="" type="radio"/> Major-ring <input type="radio"/> Sub-ring
Port 0(West)	Port 1 <input type="text"/> None <input type="text"/>
Port 1(East)	Port 2 <input type="text"/> None <input type="text"/>
ERPS Ring ID	1 <input type="text"/> ?
R-APS Channel	1000 <input type="text"/> ?
WTR Timer Interval	5 <input type="text"/> ?
Advanced Settings	<input checked="" type="checkbox"/> Enable

Advanced Settings

Major-Ring Virtual Channel	0 <input type="text"/> ?
Sub-Ring Virtual Channel	<input type="radio"/> Enable <input checked="" type="radio"/> Disable Support only when Ring Type set to "Sub-ring"
Revertive Mode	<input checked="" type="radio"/> Enable <input type="radio"/> Disable
MEL Value	7 <input type="text"/> ?

Apply

For more information, hover the mouse over the ? icon in the system.

- [ERPS Ring](#)
There are three rings supported on a device. Using the dropdown select to change the ERPS Rings.
- [Basic Settings](#)
 - [ERPS Status](#)

“Enable” or “Disable” ERPS protocol running on the switch. By default, the ERPS protocol is **disabled**.

- Ring Type

Major-ring: controls a full physical ring.

Sub-ring: connected to another ring. It does not constitute a closed ring.

- ERPS Port 0

The ERPS Port 0 is also called “**West Port**”. Select one of the switch ports to be the Port 0 of ERPS and decide the role of the port.

- ERPS Port 1

The ERPS Port 1 is also called “**East Port**”. Select one of the switch ports to be the Port 1 of ERPS and decide the role of the port.

Note: Only One of the switch ports can be configured as ERPS Port 0 or ERPS Port 1.

Role	Description
Owner	There is only one “Owner” in the ERPS ring topology. The Owner is responsible for blocking the traffic in RPL and protects one side of the RPL.
Neighbor	There is only one “Neighbor” in the ERPS ring topology. The Neighbor is the port connected with the Owner port and protects another side of the RPL.
Interconnection	The Interconnection port connects a major-ring and a sub-ring. If one of the ports on the switch is set to “Interconnection” role, the other port will be set to “Disabled” automatically.
None	The “None” implies that the port is other than an Owner or a Neighbor.

- ERPS Ring ID

The ID is the identifier of the ring. The members in the same ring must be set to the same ERPS Ring ID.

The range of the ERPS Ring ID is **from 1 to 239**.

The default ERPS Ring ID is **1**.

- R-APS Channel

The R-APS Channel is used to forward ERPS information and is mapped to the VLAN IDs. These VLAN IDs cannot be set as traffic VLAN ID. The members in the same ring must be set to the same R-APS Channel.

The range of the R-APS Channel is **from 1 to 4094**.

The default R-APS Channel is **1000**.

- WTR Timer Interval

The WTR Timer Interval is used to initial an RPL block. It happen when both revertive mode of operation or before reverting to idle state.

The range of the WTR Timer Interval is **from 1 to 12** in minutes.

The default WTR Timer Interval is **5** minutes.

- [Advanced Settings](#)

The Advanced Settings field is only displayed when the “Advanced Settings” checkbox is selected in the Basic Settings.

- [Major-Ring Virtual Channel](#)

This field is used to configure the specific virtual channel for transmitting the management packets of the sub-ring through the major-ring.

- [Sub-Ring Virtual Channel](#)

“Enable” or “Disable” using virtual channel in the sub-ring. When the Sub-Ring Virtual Channel is enabled, ERPS protocol will transmit management packets by the configured virtual channel.

- [Revertive Mode](#)

“Enable” or “Disable” the ERPS Revertive Mode. If the Revertive Mode is enabled, the blocked link will revert to the RPL link after the failed link is recovered.

By default, the ERPS Revertive Mode is **enabled**.

- [MEL Value](#)

MEL field is for the compliance with other devices which are running ITU-T G.8031 from third-party. The MEL implies the MEG Level. It is a field in the R-APS PDU. A large MEL value involves more devices. For example, level 7 contains levels 0 to 6.

The range of the MEL Value is **from 0 to 7**.

The default MEL Value is **7**.

-  (Apply Button)

After configuring above fields, click "**Apply**" button to make the changes effective.

ERPS STATUS

ERPS Status

Ring 1

Basic Information

Ring Type	Major-ring
ERPS Status	Disable
Ring State	Normal
Node State	Initial
ERPS Ring ID	1
R-APS Channel	1000
Virtual Channel	default
Revertive Mode	Yes
MEL Value	7

Port Status

	Interface	Role
Port 0(West)	Lan1	None
Port 1(East)	Lan2	None

Auto Refresh Refresh

Refresh Rate: seconds

- [ERPS Ring](#)

There are three rings supported on a device. Using the dropdown select to change the ERPS Rings.

- [Basic Information](#)

- [Ring Type](#)

The type of the selected ERPS Ring shows “Major-ring”, “Sub-ring with virtual channel”, or “Sub-ring without virtual channel”.

- [ERPS Status](#)

The status of ERPS is “Enable” or “Disable” in the selected ERPS Ring.

- [Ring State](#)

There are two states for ERPS Rings: **Normal** and **Abnormal**.

- [Node State](#)

There are three states for ERPS Nodes: **Initial**, **Idle**, **Pending**, and **Protection**.

State	Description
Initial	The ERPS protocol is disabled in the selected ring.
Idle	The ERPS protocol is enabled in the selected ring and the ERPS ring is under control by the RPL Owner.
Pending	The ERPS protocol is enabled in the selected ring. The ERPS ring is recovery from Protection state and is waiting for the wtr timer expired.
Protection	The ERPS protocol is enabled in the selected ring but one of the

	links in the ring is broken. The RPL changes to forward to keep the ring working.
--	---

- ERPS Ring ID
The ID is the identity for the selected ERPS Ring.
- R-APS Channel
This field shows the configured R-APS Channel.
- Virtual Channel
This field shows the virtual channel of sub-ring. If the field shows “default” implies the virtual channel follows the R-APS Channel.
- Revertive Mode
Show the Revertive Mode is enabled (Yes) or disabled (No).
- MEL Value
The field is the configured MEL value.
- Port Status
 - Interface
The configured port presents the ERPS port 0/1 in the ERPS protocol.
 - Role
Display the configured role for the configured port.

MRP

NOTE: MRP function can be requested as a possible project related option - as default it is not supported on the CNGE20FX4TX16MSP

Media Redundancy Protocol (MRP) is an IEC standard protocol to prevent the ring topology from loops, and it is defined as **IEC 62439-2**. The recovery time of MRP is much faster than STP and even than RSTP, so it is suitable in most Industrial Ethernet applications.

In the ring topology with MRP, the manager is called **Media Redundancy Manager (MRM)**, and the clients are called **Media Redundancy Clients (MRC)**. The **MRM** send test packets from both of its ring ports periodically to confirm the health of ring topology.

There are three states for MRP Ring Ports – **Disabled**, **Blocked**, and **Forwarding**. When the **MRP** ring is under normal operation, the network works in the **Ring-Closed** state. In the closed state, one of the **MRM** Ring Ports is blocked and the other one is forwarding, while both of the ring ports of **MRCs** are forwarding. Due to the blocked port, the topology is a logical stub and the loops are avoided. If one of the forwarding links is failed, the ring topology goes to open state, and the blocked port of **MRM** will be forwarding state to insure the transmission in the ring.

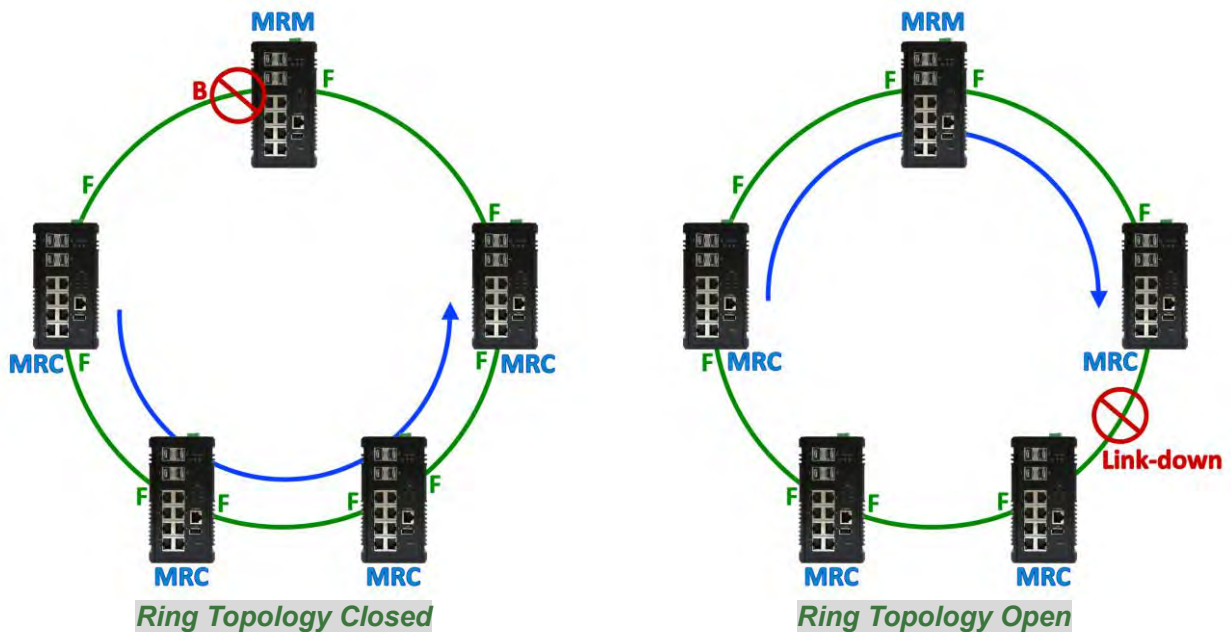

If the **MRC** detects a link down at one of the ring ports, it can notify this event to the **MRM** initiatively. In **Advanced Mode**, the **MRM** can activate the blocked ring port to speed-up recovery rather than wait till sufficient loss of test packets.

MRP standard guarantees the recovery time in the specifications. The recovery time are 500ms, 200ms, 30ms with maximum 50 switches, and 10ms with up to 14 switches in a ring. Currently, we support the recovery delay of 500ms and 200ms.

CONFIGURE MRP INFORMATION

MRP Configuration

Settings

MRP Status	<input type="radio"/> Enable <input checked="" type="radio"/> Disable
MRP Role	<input type="radio"/> Manager <input checked="" type="radio"/> Client
MRP Recovery Delay	<input checked="" type="radio"/> 500 ms <input type="radio"/> 200 ms
MRP Port 1(Primary)	None ▼
MRP Port 2(Second)	None ▼
MRP Domain Name	<input type="text"/> ?
MRP Domain ID	255.255.255.255.255.255.255.255.2 ?
Advanced Mode	<input checked="" type="checkbox"/> Enable

Apply

For more information, hover the mouse over the ? icon in the system.

• **MRP Status**

“Enable” or “Disable” MRP protocol running on the switch. By default, the MRP protocol is disabled.

• **MRP Role**

Configure the role of the switch when running MRP protocol. The “Manager” item implies MRM and the “Client” item implies MRC.

• **MRP Recovery Delay**

The MRP Recovery Delay implies to the amount of lost packets. The IEC 62439-2 standard defines 4 recovery delays – **500ms, 200ms, 30ms, and 10ms**. Currently, we only support 500ms and 200ms.

• **MRP Port 1 (Primary)**

The MRP Port 1 is the **primary port** of MRP. Select one of the switch ports to be the primary port of MRP. The Primary port is default configured to be **forwarding** when the Ring is closed.

• **MRP Port 2 (Second)**

The MRP Port 2 is the **secondary port** of MRP. Select one of the switch ports to be the secondary port of MRP. The secondary port is default configured to be **blocking** when the Ring is closed.

• **MRP Domain Name**

The MRP Domain Name is a unique string for the MRP domain to identify MRP domains

- [MRP Domain ID](#)

The MRP Domain ID is the key attribute to define the members in the same MRP ring.

The default MRP Domain ID is

255.255.255.255.255.255.255.255.255.255.255.255.255.255.

- [Advanced Mode](#)

The Advanced Mode is supported only when the MRP Role is configured to “**Manager**”. If the Advanced Mode is checked, it implies the Advanced Mode is enabled. Under the advanced mode, when the MRM received a link-down signal, the MRM activates the backup port immediately rather than waiting for the sufficient loss of test packets.

MRP STATUS – BASIC & CONFIGURE INFORMATION

MRP Status

Basic Information

Instance ID	1
Domain ID	255.255.255.255.255.255.255.255.255.255.255.255.255.255

Configure Information

Advanced Mode(react on link change)	Enabled
Role of Switch (administrative setting)	Manager
Role of Switch (real operating state)	Manager
Domain Name	
Recovery delay	500 (msec)
Port Number, Secondary	3, State: Blocked
Port Number, Primary	4, State: Blocked
Operation	Enabled

- [Basic Information](#)

- [Instance ID](#)

The Instance ID is the Ring ID. We only support one ring currently, so the Instance ID displays always **1**.

- [Domain ID](#)

The Domain ID is the identity of current MRP ring. Only the members with the same Domain ID will be regarded as working in the same ring.

- [Configured Information](#)

- [Advanced Mode](#)

The field shows the status of Advanced Mode. Advanced Mode is only supported when the switch is configured as a **MRM (Manager)**.

- [Role of Switch](#)

There are 2 roles of switches in the MRP – **Manager** and **Client**

Administrative Setting: the role that users configured for the switch.

Real Operating State: the role that the switch is working as.

- [Domain Name](#)

This field shows the configured name of this MRP Domain.

- Recovery Delay

This field shows current operating Recovery Delay. It may be **500** or **200 (msec)**.

- Port Number, Secondary

- Port Number, Primary

These two fields shows two parts of information. The first one is the switch port number configured as Primary / Secondary Port, and the other one is the state of this port. There are 3 states for MRP ports when the MRP is enabled: **Forwarding**, **Blocked**, and **Disabled**. If the MRP is disabled, the state shows **"N/A"**.

- Operation

This field shows current Operation State – **Enabled** or **Disabled**.

📍 **Operating States**

Ring State	Open
Topology Change Interval	20.0 (msec)
Topology Change Repeat Count	3
Short Test Interval	30.0 (msec)
Default Test Interval	50.0 (msec)
Test Monitoring Count	5
Nonblocking Client Supported	Enabled
Test Monitoring Extended Count	15
Check Media Redundancy	Enabled

- **Operating States (Master)**

- Ring State

The Ring State displays the actual ring state of MRP, and the state may be

Open: some of the links in the MRP ring are down or MRC failure.

Closed: the MRP ring is closed and under normal operation without error.

- Topology Change Interval

The interval is the period to send **MRP_TopologyChange** frames.

- Topology Change Repeat Count

The count is the repeat times to transmit **MRP_TopologyChange** frames.

- Short Test Interval

This interval is a timer used after **link changes** to send **MRP_Test** frames on the MRP ring ports.

- Default Test Interval

The interval is the **default** period to send **MRP_Test** frames on the MRP ring ports.

- Test Monitoring Count

This field is the interval count for monitoring the reception of **MRP_Test** frames.

- Non-blocking Client Supported

This field displays the ability of the MRM to support MRCs without **BLOCKED** port state support in the ring.

- Test Monitoring Extended Count

This field is an **optional** parameter. It is an extended interval count for monitoring the reception of **MRP_Test** frames.

- Check Media Redundancy

Check the current state of MRM. The state may be “**Enabled**” or “**Disabled**”.

📍 **Operating States**

Link Down Interval	20.0 (msec)
Link Up Interval	20.0 (msec)
Link Change Count	4
Blocked Support	Enabled

Auto Refresh Refresh

Refresh Rate: seconds ⓘ

- **Operating States (Client)**

- Link Down Interval

The Link-down Interval shows the period that MRP Link-down frames sent on the ring port. The default value of Link-down Interval is **20ms**.

- Link Up Interval

The Link-up Interval shows the period that MRP Link-up frames sent on the ring port. The default value of Link-up Interval is **20ms**.

- Link Change Count

The Link-change Count controls the repeated times to transmit MRP Link-Change frames. The default Link-change Count is **4** times.

- Blocked Support

The Blocked Support is default **enabled**. The MRM with Blocked Support will block the secondary port when there is no Blocked Port in the MRM ring topology to avoid loops.

SNMP

Simple Network Management Protocol (SNMP) is a standard for collecting and structuring information on the managed devices of the IP network. It can also modify some of the information to change the behavior of the devices. SNMP is usually used in monitoring the network. The users can remotely query the information provided by the devices running SNMP.

The switches support SNMP v1, v2c, and v3. SNMP v1 and v2c authenticates with a community string for “**read-only**” or “**read-write**” permission. The SNMP v3 authentication requires to select an authentication level (**MD5** or **SHA**) and also supports data encryption to make the data safer.

For the SNMP version and authentication method relationship, refer to the table below:

Version	Web Setting	Authentication	Encryption	Method
v1 & v2c	Read Only Community	Community String	No	String match for authentication
	Read-Write Community	Community String	No	String match for authentication
v3	Security Level – No Authentication, No Privacy	No	No	Access by an account (admin or user)
	Security Level – Authentication, No Privacy	MD5 / SHA	No	Access by an account (admin or user) and password with more than 8 characters, which is based on MD5 or SHA
	Security Level – Authentication, Privacy	MD5 / SHA	Yes AES / DES	Access by an account (admin or user) and password more than 8 characters, which is based on MD5 or SHA. The data encryption is based on AES or DES and the key requires 8 to 32 characters.

CONFIGURE SNMP SERVER INFORMATION

⚙️ SNMP Server

📍 Basic Settings

SNMP Version	v1, v2c and v3	
Read Only Community	public	?
Read-Write Community	private	?

📍 SNMPv3 Settings

👤 Admin		
Security Level	No Authentication, No Privacy	
Authentication Type	<input type="radio"/> MD5 <input checked="" type="radio"/> SHA	
Authentication Password	administrator	?
Encryption Type	<input type="radio"/> AES <input type="radio"/> DES	
Encryption Password	administrator	?
👤 User		
Security Level	No Authentication, No Privacy	
Authentication Type	<input type="radio"/> MD5 <input checked="" type="radio"/> SHA	
Authentication Password	administrator	?
Encryption Type	<input type="radio"/> AES <input type="radio"/> DES	
Encryption Password	administrator	?

Apply

*For more information, hover the mouse over the **?** icon in the system.*

- **Basic Settings**

- **SNMP Version**

The system enables the SNMP “v1, v2c and v3” authentication by default. The users can enable the SNMP server on only “v1 and v2c” or “v3”. “None” refers to disabling the SNMP server.

- **Read Only Community**

The community used to access the SNMP server with the “read-only” privilege.

The **max. length** for the Read Only Community is **32 characters**.

Note: #, \, ', ", ? are **invalid** characters.

- Read-Write Community
The community used to access the SNMP server with the “**read-write**” privilege.
The **max. length** for the Read-Write Community is **32 characters**.
Note: #, \, ', ", ? are **invalid** characters.

- **SNMPv3 Settings**

This section is displayed only when the **SNMP Version** is set to “v3” or “v1, v2c and v3”. Two accounts are provided – Admin and User to access the SNMP agent. The users can set different levels for the 2 accounts.

- Security Level
No Authentication, No Privacy: Access by an account “admin” or “user”.
Authentication, No Privacy: Access by an account “admin” or “user” with password.
Authentication, Privacy: Access by an account “admin” or “user” with password and the data will be encrypted.
- Authentication Type
Two algorithms are provided - **MD5** and **SHA** for authentication password.
- Authentication Password
A string/key is used to authenticate the SNMP Server and obtain the access permission. It will be hashed by MD5 or SHA before authentication.
The min. length for the Read-Write Community is **8 characters**.
The max. length for the Read-Write Community is **32 characters**.
Note: Only digits, letters and underline are valid.
- Encryption Type
Two algorithms are provided - **AES** and **DES** for data encryption.
- Encryption Password
A string/key is used to encrypt the data that is sent to the SNMP server.
The min. length for the Read-Write Community is **8 characters**.
The max. length for the Read-Write Community is **32 characters**.
Note: Only digits, letters and underline are valid.

-  (Apply Button)

After configuring above fields, click "**Apply**" button to make the changes effective.

CONFIGURE SNMP TRAP INFORMATION

SNMP Trap

Basic Settings

Trap Version	v3 Trap	
Inform Retry	5	?
Inform Timeout	1	?
Trap Receiver IP 1		?
Trap Receiver IP 2		?
Community	public	?

SNMPv3 Trap Settings

Username		?
Engine ID	0x8000000080f189e37802010000	?
Security Level	Authentication, No Privacy	
Authentication Type	<input checked="" type="radio"/> MD5 <input type="radio"/> SHA	
Authentication Password		?
Encryption Type	<input checked="" type="radio"/> AES <input type="radio"/> DES	
Encryption Password		?

Apply

For more information, hover the mouse over the ? icon in the system.

- Basic Settings**

- Trap Mode**

The system enables the SNMP “v1, v2c and v3” authentication by default. Users can enable the SNMP server only on “v1 and v2c” or “v3”. “None” indicates disabling the SNMP server.

- Inform Retry**

The SNMP trap will send “Retry” times when the trap set to “v2 Inform” or “v3 Inform” mode.

The range of the Inform Retry is **from 1 to 100**.

The default Inform Retry is **5**.

- Inform Timeout**

The interval is used to send trap when the trap set to “v2 Inform” or “v3 Inform” mode.

The range of the Inform Retry is **from 1 to 300 second(s)**.

The default Inform Retry is **1 second**.

- Trap Receiver IP 1 & 2

The IP address is the IP address of the trap server to receive the trap information. The system supports both **IPv4** and **IPv6** addresses for the receiver. There are 2 Trap Receiver IP supported.

- Community

The string in the SNMP trap is the identity of the device.

The max. length for the Community is **32 characters**.

Note: #, \, ', ", ? are **invalid** characters.

- SNMPv3 Trap/Inform Settings

This section is displayed only when **Trap Mode** are set to "v3 Trap" or "v3 Inform".

- Username

Specify the username for authentication with the SNMP trap server.

- Engine ID

The Engine ID is the identifier for the given SNMP application.

- Security Level

No Authentication, No Privacy: Access using the username assigned to the users.

Authentication, No Privacy: Access using the username assigned to the users with password.

Authentication, Privacy: Access using the username assigned to the users with password and the data will be encrypted.

- Authentication Type

Two algorithms are provided - **MD5** and **SHA** for authentication password.

- Authentication Password

A string/key is used to authenticate the SNMP trap server and obtain the permission. It will be hashed by MD5 or SHA before authentication.

The min. length for the Read-Write Community is **8 characters**.

The max. length for the Read-Write Community is **32 characters**.

Note: #, \, ', ", ? are **invalid** characters.

- Encryption Type

Two algorithms are provided - **AES** and **DES** for data encryption.

- Encryption Password

A string/key is used to encrypt the data sent to the SNMP trap server.

The min. length for the Read-Write Community is **8 characters**.

The max. length for the Read-Write Community is **32 characters**.

Note: #, \, ', ", ? are **invalid** characters.

-  (Apply Button)

After configuring above fields, click "**Apply**" button to make the changes effective.

DHCP

DHCP SERVER/CLIENT

DHCP, **Dynamic Host Configuration Protocol**, is a standardized protocol used in the IP networks. The DHCP Server holds an **IP address pool** and when a DHCP Client request for an IP address, the DHCP Server picks an IP address from the pool and assigns it to the client. DHCP Server also manages other IP information such as **Default Gateway** and **DNS Server**. DHCP is very useful to configure the IP information for a number of devices. Only the administrator can enable the DHCP Client for each device and setup the DHCP Server. The clients will then obtain a unique IP address and other IP settings to connect to the network.

DHCP OPTION66 & 67

Option 66 & 67 is an open standard. RFC 2132 defines it. Option 66 is used to identify a TFTP server when the **sname** field in the DHCP header. Option 67 is used to identify a boot file when the **file** field in the DHCP header has been used for DHCP options.

DHCP SERVER BINDING

Apart from dynamically allocating an IP address to a DHCP Client, the DHCP Server also provides a function to manually assign a **static IP address** to the device with a specific MAC Address. This is called as DHCP Server Binding.

DHCP RELAY/OPTION82

In a large network, there might be several subnets existed and the DHCP Client is not able to serve by DHCP Servers directly. In this case, we need a relay agent to help to transmit the request frames to the DHCP Servers. When a relay agent receives the broadcast request frame from a DHCP Client, the relay agent will transmit the frame to the DHCP Servers, which are in the same subnet by unicast.

Option 82 is an information option to identify the clients by **Circuit ID** and **Remote ID**. The **Circuit ID** is an identity containing the **interface** name and/or **VLAN** information, and the **Remote ID** is to identify the **remote host** (the relay agent). The DHCP Server can distribute an IP address to the DHCP Client according to Option 82 information and make the IP addresses more controllable.

The frame format for the **Circuit ID** is as below:

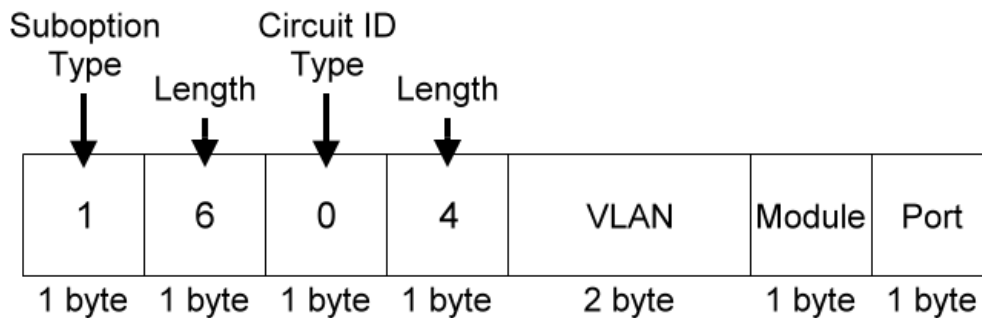

- **VLAN**
The VLAN field is for the **management VLAN ID**, which is natively set to **1**.
- **Module**
The stack number for the device sending the DHCP request is on. For industrial switches, this byte is always filled as **0**.
- **Port**
The port number identifies the incoming DHCP request frame/DHCP Client.

The frame format for the **Remote ID** is as below:

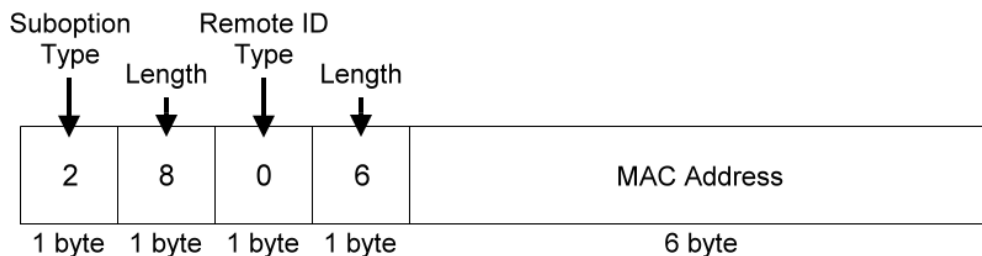

- **MAC Address**
By default, the MAC address is set to the MAC address of DHCP relay agent.

CONFIGURE DHCP CLIENT

⚙️ IPv4 Settings

The screenshot displays the IPv4 Settings configuration window. It features a light blue sidebar on the left and a white main area with a light blue background. The settings are as follows:

- IPv4 Mode:** Radio buttons for 'Static' (selected) and 'DHCP Client'.
- IP Address:** Text input field containing '192.168.10.1'.
- Subnet Mask:** Text input field containing '255.255.255.0'.
- Default Gateway:** Empty text input field.
- DNS Server:** Text input field containing '8.8.8.8'.

An 'Apply' button is positioned at the bottom right of the configuration area.

- **IPv4 Mode**

Set the **IPv4 Mode** to “**DHCP Client**” to enable the DHCP Client. The system sends a **discovery frame** to the network and tries to obtain an IP address from the DHCP Server.



After enabling the DHCP Client, users need to connect to the **Console Port** to get the IP address by using “**show ip address**” on the CLI.

-  (Apply Button)

After configuring above fields, click "**Apply**" button to make the changes effective.

CONFIGURE DHCP SERVER INFORMATION

DHCP Server

Server Status	DHCP Server Down	
Server Mode	<input type="radio"/> Enable <input checked="" type="radio"/> Disable	
Start IP Address	<input type="text"/>	
End IP Address	<input type="text"/>	
Default Gateway	<input type="text"/>	
DNS Server	<input type="text"/>	
Lease Time	<input type="text" value="86400"/>	
Option 66	<input type="text"/>	
Option 67	<input type="text"/>	

For more information, hover the mouse over the  icon in the system.

- **Server Status**
Shows the status of the DHCP server: **Down** or **Up**.
- **Server Mode**
“Enable” or “Disable” the DHCP Server function.
- **Start IP Address**
Set the range of the IP pool. The “Start IP Address” is the starting.
“Start IP Address” must be in the **same subnet** as that of the switch itself.
- **End IP Address**
Set the range of IP pool. The “End IP Address” is the end.
“End IP Address” must be in the **same subnet** as that of the switch itself.
- **Default Gateway**
Set the Default Gateway for the DHCP Clients to make them connect to the WAN.
“Default Gateway” must be in the **same subnet** as that of the switch itself.
- **DNS Server**

Set the DNS Server for the DHCP Clients to make them connect to another device based on the **URL** instead of IP address.

- [Lease Time](#)
DHCP Server leases an IP address to a device for a **period of time**. When the lease time expires, the DHCP server may assign a different IP address in the pool to the device.
- [Option 66](#)
The **URL or IP address** of provisioning sever presents in DHCP option 66 messages.
- [Option 67](#)
The **boot file name** of provisioning sever presents in DHCP option 67 messages.
-  (Apply Button)

After configuring above fields, click "**Apply**" button to make the changes effective.

DHCP LEASED TABLE

DHCP Leased Table

Show entries Search:

IP Address	MAC Address	Expired Time
192.168.10.100	68:02:35:00:16:ee	1970/01/07 22:55:49

Showing 1 to 1 of 1 entries

Auto Refresh

Refresh Rate: seconds. 

- [IP Address](#)
This field implies the IP Address that this device acquired from DHCP Server.
- [MAC Address](#)
The MAC Address of the device that acquired mapped IP Address. Administrators can use MAC Address to map to the device's IP Address.
- [Expired Time](#)
The Expired Time implies the deadline of designated IP Address that leased from DHCP Server. After Expired Time, the DHCP Client has to communicate with DHCP Server and ask for the IP Address again.



CONFIGURE DHCP SERVER BINDING INFORMATION

DHCP Server Binding

Binding ID 	MAC Address	Binding IP Address	+
<input type="text"/>	<input type="text"/>	<input type="text"/>	✕

Apply

For more information, hover the mouse over the  icon in the system.





- [Binding ID](#)
An ID used to identify the binding.
The range of the Binding ID is **from 1 to 32**.
- [MAC Address](#)
The device with the specified MAC Address will be assigned to the static Binding IP Address.
- [Binding IP Address](#)
A static IP Address will be assigned to the specified MAC Address.
- : Click the **plus icon** to add a DHCP Binding row.
- : Click the **remove icon** to delete the DHCP Binding row.
-  (Apply Button)

After configuring above fields, click "**Apply**" button to make the changes effective.

CONFIGURE DHCP RELAY INFORMATION

DHCP Relay

Basic Settings

Relay Mode	<input type="radio"/> Enable <input checked="" type="radio"/> Disable
Relay Option82	<input type="radio"/> Enable <input checked="" type="radio"/> Disable
Helper Address 1	<input type="text"/> 
Helper Address 2	<input type="text"/> 
Helper Address 3	<input type="text"/> 
Helper Address 4	<input type="text"/> 

Relay Untrust

Port	Untrust Status 
1	<input type="radio"/> Enable <input checked="" type="radio"/> Disable
2	<input type="radio"/> Enable <input checked="" type="radio"/> Disable
3	<input type="radio"/> Enable <input checked="" type="radio"/> Disable
4	<input type="radio"/> Enable <input checked="" type="radio"/> Disable
5	<input type="radio"/> Enable <input checked="" type="radio"/> Disable
6	<input type="radio"/> Enable <input checked="" type="radio"/> Disable
7	<input type="radio"/> Enable <input checked="" type="radio"/> Disable
8	<input type="radio"/> Enable <input checked="" type="radio"/> Disable
9	<input type="radio"/> Enable <input checked="" type="radio"/> Disable
10	<input type="radio"/> Enable <input checked="" type="radio"/> Disable
11	<input type="radio"/> Enable <input checked="" type="radio"/> Disable
12	<input type="radio"/> Enable <input checked="" type="radio"/> Disable

Apply

For more information, hover the mouse over the  icon in the system.

- Relay Basic Settings

- Relay Mode

“Enable” or “Disable” the DHCP Relay function.

- Relay Option82

“Enable” or “Disable” the DHCP Relay with Option82 tag.

- Helper Address 1 - 4

The **IP Addresses** of the **DHCP Servers** provide IP addresses to the DHCP Clients. A backup of Four Helper Addresses are available during breakdown.

- Relay Untrust
 - Port
Port1 to Port N, where N is based on the total port number.
 - Untrust Status
“Enable” or “Disable” to untrust the specific port. If the untrusted status is enabled on a port, the system will **drop** the DHCP management frames on the port.
-  (Apply Button)

After configuring above fields, click "**Apply**" button to make the changes effective.

PoE

The **PoE**, or **Power over Ethernet**, allows switches to provide electric power along with data on the twisted pair Ethernet cables. The Power over Ethernet defined the property as the following table. It requires category 5 cables or better to support high power levels. **PoE** is helpful when the AC power is not available or is available with high cost. It is usually used in surveillance IP cameras, I/O sensors, wireless access points, and IP telephones.

Property	802.3af (802.3at Type 1)	802.3at Type 2	802.3bt Type 3	802.3bt Type 4
Max. power delivered	15.40 W	30.0 W	60 W	100 W
Voltage range	44.0–57.0 V	50.0–57.0 V	50.0–57.0 V	52.0–57.0 V
Maximum current I _{max}	350 mA	600 mA	600 mA per pair	960 mA per pair

POWER DE-RATING PROTECTION

Due to the power supply is designed inside the devices for some models, so the power budget will decrease by the operating temperature. To ensure the functionality of PoE, we do the protection by software in the background and adjust the budget as temperature rises. Please refer to the **Hardware User Manual** for the detail of the relationship of power budget and temperature.

POE DEBUG CODE

We provide **PoE Debug Command** on the “**CLI**” for troubleshooting. When users find that the PoE functions work abnormal, users can use the command to acquire the error code. The error codes are mapping to different situations, users can understand the error codes from the following table:

Code	Description
0x00	PoE port is on.
0x01	
0x02	
0x03	
0x04	
0x06	PoE port is off. Mains voltage is higher than maximum voltage limitation.
0x07	PoE port is off. Mains voltage is lower than minimum voltage limitation.
0x11	PoE port is not defined yet, please check the PoE power input.
0x20	PoE port is off because of power budget exceeded.
0x1F	PoE port is off because of over-load state according to 802.3AF/AT.
0x43	PoE port is off because of class error.
0x81	802.3BT - compliant PD was detected using BT Port (30w)
0x85	802.3BT - SSPD was detected using BT Port (60w/95w) and operates as BT Port (30w) if requested class =< 4.

0x86	802.3BT - SSPD was detected using BT Port (60w 95w) and operates as BT Port (60w/95w) if requested class > 4.
0x90	BT Port (30w) and delivers power due to force power command.
0x91	BT Port (60w/95w) and delivers power due to force power command.
0x1B	PoE port is off because detection is in process.
0xA8	PoE port is not connected.
Others	Please contact your system administrator!!

CONFIGURE POWER OVER ETHERNET (POE)

PoE Configuration

Port	Mode			Status	Class	Voltage	Power
1	<input checked="" type="radio"/> Enable	<input type="radio"/> Disable	<input type="radio"/> Force	Off	0	-	-
2	<input checked="" type="radio"/> Enable	<input type="radio"/> Disable	<input type="radio"/> Force	Off	0	-	-
3	<input checked="" type="radio"/> Enable	<input type="radio"/> Disable	<input type="radio"/> Force	Off	0	-	-
4	<input checked="" type="radio"/> Enable	<input type="radio"/> Disable	<input type="radio"/> Force	Off	0	-	-
5	<input checked="" type="radio"/> Enable	<input type="radio"/> Disable	<input type="radio"/> Force	Off	0	-	-
6	<input checked="" type="radio"/> Enable	<input type="radio"/> Disable	<input type="radio"/> Force	Off	0	-	-
7	<input checked="" type="radio"/> Enable	<input type="radio"/> Disable	<input type="radio"/> Force	Off	0	-	-
8	<input checked="" type="radio"/> Enable	<input type="radio"/> Disable	<input type="radio"/> Force	Off	0	-	-

Apply

- Port**

Port1 to PortN, where N is based on the total PoE port number.
- Mode**

“Enable”, “Disable”, or “Force” PoE function on the specific port. If the mode is configured to “Force”, the system will provide power forcedly on the specific port even there is no device connected to this port.
- Status**

The field shows the PoE status of the specific port.

On: PoE is enabled or configured to force on the port and power is delivered on the port.

Off: PoE is enabled on the port but no Powered Device (PD) is connected.

Disabled: PoE is disabled on the port.
- Class**

The field shows the class followed by the PD. The acceptable power of the class is defined in the IEEE 802.3af/at.
- Voltage**

This field shows the output voltage that PSE provided. The power output of the boost switch will be boosted to 53V.
- Power**



The Consumption field contains provided power in watts. The PSE can provide up to 30Watts and the PDs can receive up to 25.5Watts.

-  (Apply Button)

After configuring above fields, click "**Apply**" button to make the changes effective.

CONFIGURE POE KEEP ALIVE

PoE Keep Alive

Port	Detect	IP Address 	Ping Interval 	Hold Time 
1	<input type="checkbox"/> Enable	<input type="text"/>	<input type="text" value="30"/>	<input type="text" value="60"/>
2	<input type="checkbox"/> Enable	<input type="text"/>	<input type="text" value="30"/>	<input type="text" value="60"/>
3	<input type="checkbox"/> Enable	<input type="text"/>	<input type="text" value="30"/>	<input type="text" value="60"/>
4	<input type="checkbox"/> Enable	<input type="text"/>	<input type="text" value="30"/>	<input type="text" value="60"/>
5	<input type="checkbox"/> Enable	<input type="text"/>	<input type="text" value="30"/>	<input type="text" value="60"/>
6	<input type="checkbox"/> Enable	<input type="text"/>	<input type="text" value="30"/>	<input type="text" value="60"/>
7	<input type="checkbox"/> Enable	<input type="text"/>	<input type="text" value="30"/>	<input type="text" value="60"/>
8	<input type="checkbox"/> Enable	<input type="text"/>	<input type="text" value="30"/>	<input type="text" value="60"/>



For more information, hover the mouse over the  icon in the system.

- **Port**
Port1 to PortN, where N is based on the total PoE port number.
- **Detect**
"Enable" or "Disable" to detect the Powered Device (PD) on the specific port. When the detection is enabled, the system pings the configured IP Address on every Ping Interval.
- **IP Address**
The field is the IP Address of the Powered Device (PD).
- **Ping Interval**
The Ping Interval is the duration to ping the Powered Device (PD).
The range of the Ping Interval is **from 1 to 65535** seconds.
The default Ping Interval is **30** seconds.
- **Hold Time**
The Hold Time is used when the ping fails. The system will wait for the Hold Time to expire and then try to ping the PD again.
The range of the Hold Time is **from 1 to 65535** seconds.
The default Hold Time is **60** seconds.

- **Apply** (Apply Button)

After configuring above fields, click "**Apply**" button to make the changes effective.

CONFIGURE POE SCHEDULE

PoE Schedule

Port 1

Schedule Mode
 Enable
 Disable

	Sun	Mon	Tue	Wed	Thu	Fri	Sat
00	<input type="checkbox"/>	<input type="checkbox"/>	<input type="checkbox"/>	<input type="checkbox"/>	<input type="checkbox"/>	<input type="checkbox"/>	<input type="checkbox"/>
01	<input type="checkbox"/>	<input type="checkbox"/>	<input type="checkbox"/>	<input type="checkbox"/>	<input type="checkbox"/>	<input type="checkbox"/>	<input type="checkbox"/>
02	<input type="checkbox"/>	<input type="checkbox"/>	<input type="checkbox"/>	<input type="checkbox"/>	<input type="checkbox"/>	<input type="checkbox"/>	<input type="checkbox"/>
03	<input type="checkbox"/>	<input type="checkbox"/>	<input type="checkbox"/>	<input type="checkbox"/>	<input type="checkbox"/>	<input type="checkbox"/>	<input type="checkbox"/>
04	<input type="checkbox"/>	<input type="checkbox"/>	<input type="checkbox"/>	<input type="checkbox"/>	<input type="checkbox"/>	<input type="checkbox"/>	<input type="checkbox"/>
05	<input type="checkbox"/>	<input type="checkbox"/>	<input type="checkbox"/>	<input type="checkbox"/>	<input type="checkbox"/>	<input type="checkbox"/>	<input type="checkbox"/>
06	<input type="checkbox"/>	<input type="checkbox"/>	<input type="checkbox"/>	<input type="checkbox"/>	<input type="checkbox"/>	<input type="checkbox"/>	<input type="checkbox"/>
07	<input type="checkbox"/>	<input type="checkbox"/>	<input type="checkbox"/>	<input type="checkbox"/>	<input type="checkbox"/>	<input type="checkbox"/>	<input type="checkbox"/>
08	<input type="checkbox"/>	<input type="checkbox"/>	<input type="checkbox"/>	<input type="checkbox"/>	<input type="checkbox"/>	<input type="checkbox"/>	<input type="checkbox"/>
09	<input type="checkbox"/>	<input type="checkbox"/>	<input type="checkbox"/>	<input type="checkbox"/>	<input type="checkbox"/>	<input type="checkbox"/>	<input type="checkbox"/>
10	<input type="checkbox"/>	<input type="checkbox"/>	<input type="checkbox"/>	<input type="checkbox"/>	<input type="checkbox"/>	<input type="checkbox"/>	<input type="checkbox"/>
11	<input type="checkbox"/>	<input type="checkbox"/>	<input type="checkbox"/>	<input type="checkbox"/>	<input type="checkbox"/>	<input type="checkbox"/>	<input type="checkbox"/>
12	<input type="checkbox"/>	<input type="checkbox"/>	<input type="checkbox"/>	<input type="checkbox"/>	<input type="checkbox"/>	<input type="checkbox"/>	<input type="checkbox"/>
13	<input type="checkbox"/>	<input type="checkbox"/>	<input type="checkbox"/>	<input type="checkbox"/>	<input type="checkbox"/>	<input type="checkbox"/>	<input type="checkbox"/>
14	<input type="checkbox"/>	<input type="checkbox"/>	<input type="checkbox"/>	<input type="checkbox"/>	<input type="checkbox"/>	<input type="checkbox"/>	<input type="checkbox"/>
15	<input type="checkbox"/>	<input type="checkbox"/>	<input type="checkbox"/>	<input type="checkbox"/>	<input type="checkbox"/>	<input type="checkbox"/>	<input type="checkbox"/>
16	<input type="checkbox"/>	<input type="checkbox"/>	<input type="checkbox"/>	<input type="checkbox"/>	<input type="checkbox"/>	<input type="checkbox"/>	<input type="checkbox"/>
17	<input type="checkbox"/>	<input type="checkbox"/>	<input type="checkbox"/>	<input type="checkbox"/>	<input type="checkbox"/>	<input type="checkbox"/>	<input type="checkbox"/>
18	<input type="checkbox"/>	<input type="checkbox"/>	<input type="checkbox"/>	<input type="checkbox"/>	<input type="checkbox"/>	<input type="checkbox"/>	<input type="checkbox"/>
19	<input type="checkbox"/>	<input type="checkbox"/>	<input type="checkbox"/>	<input type="checkbox"/>	<input type="checkbox"/>	<input type="checkbox"/>	<input type="checkbox"/>
20	<input type="checkbox"/>	<input type="checkbox"/>	<input type="checkbox"/>	<input type="checkbox"/>	<input type="checkbox"/>	<input type="checkbox"/>	<input type="checkbox"/>
21	<input type="checkbox"/>	<input type="checkbox"/>	<input type="checkbox"/>	<input type="checkbox"/>	<input type="checkbox"/>	<input type="checkbox"/>	<input type="checkbox"/>
22	<input type="checkbox"/>	<input type="checkbox"/>	<input type="checkbox"/>	<input type="checkbox"/>	<input type="checkbox"/>	<input type="checkbox"/>	<input type="checkbox"/>
23	<input type="checkbox"/>	<input type="checkbox"/>	<input type="checkbox"/>	<input type="checkbox"/>	<input type="checkbox"/>	<input type="checkbox"/>	<input type="checkbox"/>

Apply

- **Port Selector**
Select the port number to configure the PoE Schedule.
Port1 to PortN, where N is based on the total PoE port number.
- **Schedule Mode**
“Enable” or “Disable” to provide power by the schedule on the specific port.
- **Enable** (for each day)

The week is from Sunday to Saturday.

- **Week** (The x-ray of the table)
The week is from Sunday to Saturday.

- **Hour** (The y-ray of the table)
The hour is from 00 (00:00) to 23 (23:00).

Users can select the checkbox with the Week and Hour in the table to enable the PoE Schedule on the specific time. For example, if the user wants the PoE to be enabled only on Monday from 6:00 to 7:00 and on Wednesday from 13:00 to 15:00, the following checkboxes must be selected – “Mon-06”, “Mon-07”, “Wed-13”, “Wed-14”, and “Wed-15”.

- **Apply** (Apply Button)

After configuring above fields, click "**Apply**" button to make the changes effective.

CONFIGURE POE PRIORITY

From **v1.1.48**, we remove “**Priority Mode**” and “**Power Limit**” for each port configurations in the PoE Priority Page because of the support of the PoE chipset.

From **v1.1.77**, all PoE Models (including MP/MT/MH/MQ/CP/CT/CH/CQ) support PoE Priority function including 60W/95W 802.3bt switches.

PoE Priority

Basic Settings

Power Budget	<input type="text" value="240"/>	
--------------	----------------------------------	---

Power Settings

Port	Priority
1	<input type="text" value="Low"/>
2	<input type="text" value="Low"/>
3	<input type="text" value="Low"/>
4	<input type="text" value="Low"/>
5	<input type="text" value="Low"/>
6	<input type="text" value="Low"/>
7	<input type="text" value="Low"/>
8	<input type="text" value="Low"/>

Apply

For more information, hover the mouse over the  icon in the system.

- **Basic Setting**

- Power Budget

This field defines the **maximum power** that can provide to all the connected PDs.

The range of Power Budget is **from 1 to 240** Watt.

The default Power Budget is **240** Watt.

- Power Settings

- Port

Port1 to PortN, where N is based on the total PoE port number.

- Priority

Assign the PoE priority to **high, middle, or low** for the specific port.

-  (Apply Button)

After configuring above fields, click "**Apply**" button to make the changes effective.

Industrial Protocols

Industrial Protocols are supported on all models **except** 0802GA series.

There are three industrial protocols provided in the switch – **EtherNet/IP**, **PROFINET**, and **Modbus/TCP**.

EtherNet/IP is an **industrial network protocol** that linked up the Common Industrial Protocol (CIP) with standard Ethernet. EtherNet/IP takes advantage of both of the **Internet Protocol suite** and **IEEE 802 standard**, which are the most widely deployed collections of Ethernet standards, to define the features and functions for its transportation, networking, data link and physical layers. CIP makes use of **object-oriented design** to provide EtherNet/IP with the services and device profiles needed for real-time control applications. The object-oriented design of the CIP is also used to promote consistent implementation of automation functions into a diverse ecosystem of products. EtherNet/IP defines how to organize the data in a TCP/UDP packet and transfers the packet in the application layer.

Modbus is a popular communication protocol used for the **industrial serial devices**. It is usually working as “**master-slave**” architecture and working with **programmable logic controllers** which are also called **PLCs**. The Modbus/TCP implies to provide Modbus Messaging service on the TCP/IP, so that the devices which are running Modbus can communicate with each other with Modbus messages. The Modbus messages are encapsulated with an Ethernet TCP/IP wrapper on the basis of the standard. During the transmission, the switches can only acquire the encapsulated information when the Modbus/TCP is enabled. If users would like to understand the real content of Modbus message, users have to install other utilities such as “ModScan”. Our switches implement the Modbus/TCP registers including system information, firmware information, port information, and packet information. The details refer to the “Modbus Data Mapping Information” section.

PROFINET is a technical standard for automation data communication over Industrial Ethernet. It is designed for collecting data and controlling devices in industrial systems. **PROFINET** is maintained and supported by **PROFIBUS & PROFINET International (PI)**. It defines entire data exchange not only IO-controllers and IO-devices but also parameter setting and diagnosis. **PROFINET** is useful for production and process automation, safety applications, and all range of drive technology while these applications are implemented.

MODBUS DATA FORMAT AND FUNCTION CODE

The primary four types of Modbus/TCP data format are as following:

Data Access Type		Function Code	Function Name
Bit Access	Physical Discrete Inputs	2	Read Discrete Inputs
	Internal Bits or Physical Coils	1	Read Coils
Word Access (16-bit Access)	Physical Input Registers	4	Read Input Registers
	Physical Output Registers	3	Read Holding Registers

MODBUS DATA MAPPING INFORMATION

In the following tables, we assume the total port number is **28**.

The following table is for **Function Code 3 (Holding Registers) / Function Code 6**.

Address Offset	Data Type	Interpretation	Description
System Information			
0x0000 to 0x0008	1 word	HEX	Port 1 to Port 8 Status Configuration 0x0000: Disable 0x0001: Enable

The following table is for **Function Code 4 (Input Registers)**. The data map addresses in the following table starts from **Modbus address 30001**. For example, the address offset 0x0000H equals Modbus address 30001, and the address offset 0x0030H equals Modbus address 30049. All the information read from our switches is in the **HEX mode** and users can refer to the ASCII table for the translation (e.g. 0x4B='K', 0x74='t').

Address Offset	Data Type	Interpretation	Description
System Information			
0x0030	20 words	ASCII	Product Name = "MT-0804G" Word 0 Hi byte = 'M' Word 0 Lo byte = 'T' Word 1 Hi byte = '-' Word 1 Lo byte = '0' Word 2 Hi byte = '8' Word 2 Lo byte = '0' Word 3 Hi byte = '4' Word 3 Lo byte = 'G'
0x0050	1 word		Product Serial Number
0x0051	2 words	HEX	Firmware Version For example: Word 0 = 0x0103 Word 1 = 0x0200 Firmware version is 1.3.2
0x0053	2 words	HEX	Firmware Release Date

			For example: Word 0 = 0x1719 Word 1 = 0x1506 Firmware was released on 2015-06-17 at 19 o'clock
0x0056	3 words	HEX	Ethernet MAC Address Ex: MAC = 01:02:03:0A:0B:0C Word 0 Hi byte = 0x01 Word 0 Lo byte = 0x02 Word 1 Hi byte = 0x03 Word 1 Lo byte = 0x0A Word 2 Hi byte = 0x0B Word 2 Lo byte = 0x0C
0x0059	1 word	HEX	Power 1 0x0000: Off 0x0001: On
0x005A	1 word	HEX	Power 2 0x0000: Off 0x0001: On
0x005B	1 word	HEX	Fault LED Status 0x0000: Boot error 0x0001: Normal 0x0002: Fault
0x0082	1 word	HEX	DO1 0x0000: Off 0x0001: On
Port Information			
0x1000 to 0x1008	1 word	HEX	Port 1 to Port 8 Status 0x0000: Link down 0x0001: Link up 0x0002: Disable 0xFFFF: No port
0x1100 to 0x1108	1 word	HEX	Port 1 to Port 8 Speed 0x0000: 10M-Half 0x0001: 10M-Full 0x0002: 100M-Half 0x0003: 100M-Full 0xFFFF: No port
0x1200 to 0x1208	1 word	HEX	Port 1 to Port 8 Flow Ctrl 0x0000: Off

			0x0001: On 0xFFFF: No port
0x1300 to 0x1313 (Port 1) 0x1314 to 0x1327 (Port 2) ... 0x138C to 0x139F (Port 8)	20 words	ASCII	Port 1 to Port 8 Description Port Description = "100Tx,RJ45." Word 0 Hi byte = '1' Word 0 Lo byte = '0' Word 1 Hi byte = '0' Word 1 Lo byte = 'T' ... Word 4 Hi byte = '4' Word 4 Lo byte = '5' Word 5 Hi byte = '.' Word 5 Lo byte = '\0'
0x1500 to 0x1508	1 Word	HEX	Port 1 to Port 8 PoE Status 0x0000: PoE Off 0x0001: PoE On
0x1600 to 0x1608	1 Word	HEX	Port 1 to Port 8 PoE Power in Watt
Packet Information			
0x2000 to 0x200F	2 words	HEX	Port 1 to Port 8 Tx Packets Ex: port 1 Tx Packet Amount = 13248635 Received Modbus response: 0x13248635 Word 0 = 1324 Word 1 = 8635
0x2080 to 0x208F	2 words	HEX	Port 1 to Port 8 Tx Bytes Ex: port 1 Tx Bbytes Amount = 13248635 Received Modbus response: 0x13248635 Word 0 = 1324 Word 1 = 8635
0x2100 to 0x21(Y Y*2-1)	2 words	HEX	Port 1 to YY Rx Packets Ex: port 1 Rx Packet Amount = 13248635 Received Modbus response: 0x13248635 Word 0 = 1324 Word 1 = 8635
0x2180 to 0x218F	2 words	HEX	Port 1 to Port 8 Rx Bytes Ex: port 1 Rx Bbytes Amount = 13248635 Received Modbus response: 0x13248635 Word 0 = 1324 Word 1 = 8635

ETHERNET/IP CIP OBJECT MAPPING INFORMATION

The following communication objects that defined in Common Industrial Protocol (CIP) are supported in switches for PLCs and SCADA systems to monitor:

- Identity Object
- TCP/IP Interface Object
- Ethernet Link Object
- Proprietary Object

The following tables introduce the supported attributes, including access rules for each attribute, and services for the above objects. Users can also refer to the official documents of CIP introduction (Vol. 1) and the Ethernet/IP Adaption of CIP (Vol. 2) to understand the details of each attribute of the standard objects.

Identity Object

The Class code of Identity object is defined in **CIP Vol 1, 5-2** and the value is **0x01**.

Class Attribute List

Addr ID	Access Rule	Name	Data Type	Description
1	Get	Revision	UINT (16)	Revision of this object
2	Get	Max Instance	UINT (16)	Maximum instance number of an object currently created in this class level of the device
3	Get	Number of Instances	UINT (16)	Number of object instances currently created in this class level of the device.
6	Get	Maximum ID Number Class Attributes	UINT (16)	The attribute ID number of the last class attribute of the class definition implemented in the device
7	Get	Maximum ID Number Instance Attributes	UINT (16)	The attribute ID number of the last instance attribute of the class definition implemented in the device

Instance Attribute List

Addr ID	Access Rule	Name	(Struct.)	Data Type	Description
1	Get	Vendor ID		UINT (16)	The vendor ID of company
2	Get	Device Type		UINT (16)	0x0, "Managed Ethernet Switch"
3	Get	Product Code		UINT (16)	N/A
4	Get	Revision		(Struct.)	The version of the Identity object
			Major	USINT (8)	The structure member, major
			Minor	USINT (8)	The structure member, minor

5	Get	Status		WORD (16)	Not used
7	Get	Product Name		SHORT_STRING	The product name in human-readable format
101	Get	Serial Number		UDINT (32)	The serial number of each device

Common Service List

Service Code	Implementation		Service Name	Description
	Class	Instance		
0x01	✓	✓	Get_Attributes_All	Return the contents of all attributes of the class
0x0E	✓	✓	Get_Attributes_Single	Used to read an object instance attribute
0x10		✓	Set_Attributes_Single	Used to write an object instance attribute
0x05		✓	Reset	Invokes the reset service for the device

TCP/IP Interface Object

The Class code of TCP/IP Interface object is defined in **CIP Vol 2, 5-3** and the value is **0xf5**.

Class Attribute List

Addr ID	Access Rule	Name	Data Type	Description
1	Get	Revision	UINT (16)	Revision of this object
2	Get	Max Instance	UINT (16)	Maximum instance number of an object currently created in this class level of the device
3	Get	Number of Instances	UINT (16)	Number of object instances currently created in this class level of the device.
6	Get	Maximum ID Number Class Attributes	UINT (16)	The attribute ID number of the last class attribute of the class definition implemented in the device
7	Get	Maximum ID Number Instance Attributes	UINT (16)	The attribute ID number of the last instance attribute of the class definition implemented in the device

Instance Attribute List

Addr ID	Access Rule	Name	(Struct.)	Data Type	Description
1	Get	Status		DWORD (32)	Interface status 0 = The Interface Configuration attribute has not been configured. 1 = The Interface Configuration attribute contains valid configuration obtained from BOOTP, DHCP or non-volatile storage

2	Get	Configuration Capability		DWORD (32)	Interface capability flags Bit map of capability flags: Bit 0: BOOTP Client Bit 1: DNS Client Bit 2: DHCP Client Bit 3: DHCP-DNS Update Bit 4: Configuration Settable
3	Get/Set	Configuration Control		DWORD (32)	Interface control flags Bit map of control flags: Bit 0 to 3: Startup Configuration 0 = The device shall use the interface configuration values previously stored (for example, in non-volatile memory or via hardware switches). 1 = The device shall obtain its interface configuration values via BOOTP. 2 = The device shall obtain its interface configuration values via DHCP upon start-up. 3 to15 = Reserved.
4	Get	Physical Link Object		(Struct.)	Path to physical link object
			Path Size	UINT (16)	Size of Path
			Path	Padded EPATH	Logical segments identifying the physical link object
5	Get/Set	Interface Configuration		(Struct.)	TCP/IP network interface configuration
			IP Address	UDINT (32)	The device's IP address
			Network Mask	UDINT (32)	The device's network mask
			Gateway Address	UDINT (32)	Default gateway address
			Name Server	UDINT (32)	Primary name server
			Name Server 2	UDINT (32)	Secondary name server
			Domain Name	STRING	Default domain name
6	Get/Set	Host Name		UDINT (32)	Host name

Common Service List

Service Code	Implementation		Service Name	Description
	Class	Instance		
0x01	✓	✓	Get_Attributes_All	Return the contents of all attributes of the class

0x0E	✓	✓	Get_Attributes_Single	Used to read an object instance attribute
0x10		✓	Set_Attributes_Single	Used to write an object instance attribute

Ethernet Link Object

The Class code of TCP/IP Interface object is defined in **CIP Vol 2, 5-4** and the value is **0xf6**. There is an instance for each switch port, and mapping as the following table:

Instance Number	Mapping to
0	Ethernet Link class
1	1 st switch port
2	2 nd switch port
3	3 rd switch port
...	N th switch port

Class Attribute List

Addr ID	Access Rule	Name	Data Type	Description
1	Get	Revision	UINT (16)	Revision of this object
2	Get	Max Instance	UINT (16)	Maximum instance number of an object currently created in this class level of the device
3	Get	Number of Instances	UINT (16)	Number of object instances currently created in this class level of the device.
6	Get	Maximum ID Number Class Attributes	UINT (16)	The attribute ID number of the last class attribute of the class definition implemented in the device
7	Get	Maximum ID Number Instance Attributes	UINT (16)	The attribute ID number of the last instance attribute of the class definition implemented in the device

Instance Attribute List

Addr ID	Access Rule	Name	(Struct.)	Data Type	Description
1	Get	Interface Speed		UDINT (32)	Interface speed currently in use (Speed in Mbps, e.g., 0, 10, 100, 1000, 10000, etc.)
2	Get	Interface Flags		DWORD (32)	Refer to the Interface Flags table
3	Get	Physical Address		ARRAY of 6 USINT (8)	MAC layer address (The System MAC address)
4	Get	Interface Counters		(Struct.)	Counters relevant to the receipt of packets
			In Octets	UDINT (32)	Octets received on the interface.
			In Ucast Packets	UDINT (32)	Unicast packets received on the interface
			In NUCast Packets	UDINT (32)	Non-unicast packets received on the interface

			In Discards	UDINT (32)	Inbound packets received on the interface but are discarded
			In Errors	UDINT (32)	Inbound packets that contain Errors (does not include In Discards)
			In Unknown Protos	UDINT (32)	Inbound packets with unknown protocol
			Out Octets	UDINT (32)	Octets sent on the interface
			Out Ucast Packets	UDINT (32)	Unicast packets sent on the interface
			Out NUcast Packets	UDINT (32)	Non-unicast packets sent on the interface
			Out Discards	UDINT (32)	Discarded outbound packets
			Out Errors	UDINT (32)	Outbound packets that contain errors
6	Get/Set	Interface Control		(Struct.)	Configuration for physical interface
			Control Bits	WORD (16)	Bit 0 : Auto-Negotiate Value 0: Force Value 1: Auto-Nego Bit 1 : Half/Full Duplex Value 0: half duplex Value 1: full duplex Bit 2 to 15 : Reserved, all zero
			Forced Interface Speed	UINT (16)	Speed at which the interface shall be forced to operate
7	Get	Interface Type		USINT	Value 0 : Unknown interface type. Value 1 : The interface is internal to the device, for example, in the case of an embedded switch. Value 2 : Twisted-pair (e.g., 10Base-T, 100Base-TX, 1000Base-T, etc.) Value 3 : Optical fiber (e.g., 100Base-FX) Value 4 to 256 : Reserved
8	Get	Interface State		USINT	Value 0 : Unknown interface state Value 1 : The interface is enabled and is ready to send and receive data Value 2 : The interface is disabled Value 3 : The interface is testing Value 4 to 256 : Reserved
9	Get	Admin State		USINT	Value 0 : Reserved Value 1 : Enable the interface Value 2 : Disable the interface. If this is the only CIP communications

					interface, a request to disable the interface shall result in an error (status code 0x09). Value 3 to 256 : Reserved
10	Get	Interface Label		SHORT_STRING	Human readable identification
101	Get	PoE Status		USINT (8)	Value 1 : PoE On Value 2 : PoE Off
102	Get	PoE Power		UDINT (32)	PoE Power in Watt
103	Get/Set	PoE Mode		UDINT (32)	Value 0 : Unknown Value 1 : Enable Value 2 : Disable Value 3 : Force

Interface Flags

Bit(s)	Called	Definition
0	Link Status	0 indicates an inactive link; 1 indicates an active link.
1	Half/Full Duplex	0 indicates half duplex; 1 indicates full duplex.
2-4	Negotiation Status	Indicates the status of link auto-negotiation 0 = Auto-negotiation in progress. 1 = Auto-negotiation and speed detection failed. Using default values for speed and duplex. Default values are product-dependent; recommended defaults are 10Mbps and half duplex. 2 = Auto negotiation failed but detected speed. Duplex was defaulted. Default value is product-dependent; recommended default is half duplex. 3 = Successfully negotiated speed and duplex. 4 = Auto-negotiation not attempted. Forced speed and duplex.
5	Manual Setting Requires Reset	0 indicates the interface can activate changes to link parameters (auto-negotiate, duplex mode, interface speed) automatically. 1 indicates the device requires a Reset service be issued to its Identity Object in order for the changes to take effect.
6	Local Hardware Fault	0 indicates the interface detects no local hardware fault; 1 indicates a local hardware fault is detected. The meaning of this is product-specific. For example, an AUI/MII interface might detect no transceiver attached, or a radio modem might detect no antenna attached. In contrast to the soft, possibly self-correcting nature of the Link Status being inactive, this is assumed a hard-fault requiring user intervention.
7-31	Reserved	Shall be set to zero

Common Service List

Service Code	Implementation		Service Name	Description
	Class	Instance		
0x0E	✓	✓	Get_Attributes_Single	Used to read an object instance attribute
0x10		✓	Set_Attributes_Single	Used to write an object instance attribute

Proprietary Object

The Class code of Proprietary object is defined by vendor, and the value is **0x1C1**.

Class Attribute List

Addr ID	Access Rule	Name	Data Type	Description
1	Get	Power 1	USINT (8)	Power 1 status. Value 1 : On Value 0 : Off
2	Get	Power 2	USINT (8)	Power 2 status. Value 1 : On Value 0 : Off
3	Get	Alarm Relay	USINT (8)	Alarm Relay status. Value 1 : On Value 0 : Off
4	Get	Digital Input	USINT (8)	Digital Input status. Value 1 : High Value 0 : Low
5	Get	System Time	UDINT (32)	System Time encodes as unix time.
6	Get	All Interface Speed	ARRAY of 28 UDINT(32)	Array list of all interface speed currently in use
7	Get	All Interface Flags	ARRAY of 28 DWORD(32)	Array list of all interface flags. Refer to the Interface Flags table
8	Get	All Interface States	UDINT (32)	Bitwise of all current interface states. Bit 0 : Port 1 Value 0 : Link down Value 1 : Link up Bit 1 : Port 2, and so on

ETHERNET/IP ELECTRONIC DATA SHEET (EDS) FILE

The EDS (Electronic Data Sheet) file includes electronic descriptions of all relevant communication parameters and objects of an EtherNet/IP device. It is required for I/O controllers to recognize switch and its CIP capability.

The list includes the sections which are described in our EDS file.

- [\[File\]](#)
- [\[Device\]](#)
- [\[Device Classification\]](#)
- [\[Port\]](#)
- Icon should be **32 * 32** in pixel.

PROFINET PARAMETERS MAPPING INFORMATION

There are three categories of parameters – Device Parameters, Device Status, and Port Parameters.

- r/w: Read and Write
- ro: Read Only

Device Parameters

Byte	Name	Access	Value	Description	Default Value
0	Status Alarm	rw	0	Do not send any alarms	0: No Alarms
			1	Send alarm if any status change	
1	Power Alarm 1	rw	0	Do not send power failed alarms	0: No Alarms
			1	Send alarm if power supply 1 fails	
2	Power Alarm 2	rw	0	Do not send power failed alarms	0: No Alarms
			1	Send alarm if power supply 2 fails	

Device Status

Byte	Name	Access	Value	Description
0	Overall Device Status	ro	0	Unavailable
			1	OK
			2	Device Error
1	Fault Status	ro	0	Unavailable
			1	OK
			2	Device Detect Fault
2	Power 1 Status	ro	0	Unavailable
			1	OK
			2	Power 1 Fails
3	Power 2 Status	ro	0	Unavailable
			1	OK
			2	Power 2 Fails
4	Relay 1	ro	0	Unavailable
			1	Closed
			2	Open
5	Relay 2	ro	0	Unavailable
			1	Closed
			2	Open
6	Redundant Mode	ro	0	Unavailable
			1	RSTP
			2	ERPS
			3	ERPS Sub-ring 1
			4	ERPS Sub-ring 2

7	Ring Status	ro	0	Unavailable
			1	Healthy
			2	Break
8	Redundant Port 1 Status	ro	0	Unavailable
			1	Forwarding
			2	Blocking
			3	Link Down
9	Redundant Port 2 Status	ro	0	Unavailable
			1	Forwarding
			2	Blocking
			3	Link Down
10	Sub-ring Mode	ro	0	Unavailable
			1	Healthy
			2	Break
11	Sub-ring Port 1 Status	ro	0	Unavailable
			1	Forwarding
			2	Blocking
			3	Link Down
12	Sub-ring Port 2 Status	ro	0	Unavailable
			1	Forwarding
			2	Blocking
			3	Link Down
13	Connection	ro	0	Unavailable
			1	OK
			2	Connection Failure

Port Parameters

Byte	Name	Access	Value	Description
0	Port Alarm	rw	0	Off, do not send alarm
			1	On, send alarm when port link down
1	Port Admin State	rw	0	Unavailable
			1	Off, inactive
			2	On, active
2	Port Link State	ro	0	Unavailable
			1	Link is down
			2	Link is up
3	Port Speed	ro	0	Unavailable
			1	Unknown
			2	10M
			3	100M
			4	1G
			5	10G
4	Port Duplex	ro	0	Unavailable
			1	Half
			2	Full

5	Port Auto-negotiation	ro	0	Unavailable
			1	Off
			2	On
6	Port Flow Control	ro	0	Unavailable
			1	Off
			2	On
7	Port MDI/MDIX	ro	0	Unavailable
			1	MDI
			2	MDIX

CONFIGURE INDUSTRIAL PROTOCOLS INFORMATION

Note: For PoE models, the system will take around **10 seconds** to read PoE status.

Industrial Protocols

Modbus/TCP

Modbus Mode Enable Disable

Ethernet/IP

Ethernet/IP Mode Enable Disable

Profinet

Profinet Mode Enable Disable

Apply

- [Modbus Mode](#)
"Enable" or "Disable" the Modbus/TCP function.
- [Ethernet/IP Mode](#)
"Enable" or "Disable" the Ethernet/IP function.
- [PROFINET Mode](#)
"Enable" or "Disable" the PROFINET function.
-  (Apply Button)

After configuring above fields, click "**Apply**" button to make the changes effective.

UPnP

UPnP is **Universal Plug and Play**, a set of networking protocols that permit the network devices to seamlessly discover each other in the networks. It is promoted by the UPnP Forum, but since 2016, all UPnP efforts are managed by the Open Connectivity Foundation.

UPnP extends “**plug and play**” to connect to a network device without configuration. When an UPnP device such as printer, Wi-Fi AP, or mobile device connects to a network, it will automatically establish the working configurations with another devices.

CONFIGURE UPnP INFORMATION

UPnP



For more information, hover the mouse over the  icon in the system.

- [UPnP Mode](#)

“Enable” or “Disable” the UPnP function.

- [Advertisement Interval](#)

A time period used to send the UPnP advertisement frame.

The range of the Advertisement Interval is **from 300 to 86400** seconds.

The default Advertisement Interval is **1800** seconds.

-  (Apply Button)

After configuring above fields, click "**Apply**" button to make the changes effective.

Port Management

Port Management contains a “Description” field that is used to describe the port, “Enable” or “Disable” option to turn on or turn off a specific port, configure the speed-duplex for the port, and Flow Control on the port. In the Port Status page, the users can obtain information such as Link Status, Speed, Duplex, Flow Control, Tx and Rx in Bytes, and PoE status. These are very helpful for the administrator to manage the interfaces on the switch.

CONFIGURE PORT INFORMATION

Port Settings

Port	Description 	Link Status	Admin Status	Speed	Flow Control
1	<input type="text"/>	Down	Enable ▾	Auto ▾	Off ▾
2	<input type="text"/>	Up	Enable ▾	Auto ▾	Off ▾
3	<input type="text"/>	Down	Enable ▾	Auto ▾	Off ▾
4	<input type="text"/>	Down	Enable ▾	Auto ▾	Off ▾
5	<input type="text"/>	Down	Enable ▾	Auto ▾	Off ▾
6	<input type="text"/>	Down	Enable ▾	Auto ▾	Off ▾
7	<input type="text"/>	Down	Enable ▾	Auto ▾	Off ▾
8	<input type="text"/>	Down	Enable ▾	Auto ▾	Off ▾
9	<input type="text"/>	Down	Enable ▾	Auto ▾	Off ▾
10	<input type="text"/>	Down	Enable ▾	Auto ▾	Off ▾
11	<input type="text"/>	Down	Enable ▾	Auto ▾	Off ▾
12	<input type="text"/>	Down	Enable ▾	Auto ▾	Off ▾

Apply

For more information, hover the mouse over the  icon in the system.

- **Port**
Port1 to PortN, where N is based on the total port number.
- **Description**
The description for the port is helpful for the administrator to identify the difference between the ports.
The **max. length** for the Description is **32 characters**.
Note: #, \, ', ", ? are **invalid** characters.

- [Link Status](#)

Link Status shows “Up”, “Down”, or “Disable” to reflect the link status of the port.

- [Admin Status](#)

“Enable” or “Disable” the Admin Status of the port to restrict the transmission on the port.

Note: Administrator can **turn off the un-used port** to **secure** the network with unexpected device.

- [Speed](#)

The users are able to manually fix the speed and duplex or automatically run auto-negotiation to determine the speed and duplex for copper ports.

- [Auto](#): The port follows IEEE 802.3 protocol to auto-negotiate with connected device.
- 100M-Full: The port transmits frames with **100Mbps** per second speed and **full duplex**.
- 100M-Half: The port transmits frames with **100Mbps** per second speed and **half duplex**.
- 10M-Full: The port transmits frames with **10Mbps** per second speed and **full duplex**.
- 10M-Half: The port transmits frames with **10Mbps** per second speed and **half duplex**.

The users have to manually configure SFP ports to fix the speed and duplex. The default setting is the highest speed for the SFP slot.

- Auto: The port follows IEEE 802.3 protocol to auto-negotiate with connected device.
- 10G-Full (**Only supported on 10G models**)
The port transmits frames with **10Gbits** per second speed and **full duplex**.
- 1G-Full: The port transmits frames with **1Gbits** per second speed and **full duplex**.
- 100M-Full (**Only supported on dual speed SFP ports**)
The port transmits frames with **100Mbps** per second speed and **full duplex**.
- Copper-Full: Select Copper-Full when using **copper SFP** module.

Note1: 1G(Auto, 1G-Full, Copper-Full) and 10G(10G-Full) of fiber ports cannot exist at the same time.

Note2: Configure the port speed to "1G-Full" if users need the **VDSL2 SFP** supported.

Configure the port speed to “Auto” if the connected device is unmanaged.

For **Copper SFP Module**, please refer to the following instructions to configure the correct speed:

Copper SFP Module Type	Speed Config	Note
SGMII (10/100/1000M)	Copper-Full	Only support transmitting on 1000M
Multi-Speed (1G/10G)	10G-Full	Depends on the connected speed
10G	10G-Full	
1G / VDSL2	1G-Full	

- [Flow Control](#)

“Enable” or “Disable” the Flow Control when the speed is set to “Auto”. Enabling the Flow Control helps to prevent the traffic from losing when the network is in congestion.

-  (Apply Button)

After configuring above fields, click "**Apply**" button to make the changes effective.

SFP DDM STATUS

SFP DDM

SFP Port 9

Transceiver Info

Vendor Name	-
Part number	-
Transceiver Type	Unknown
Laser wavelength	0nm
Link length	-

- [SFP Port Selector](#)

Select the SFP port number to display SFP DDM information.

- [Transceiver Info](#)

If there is no SFP module inserted or the information cannot be read, the field will show “-”.

- [Vendor Name](#)

This field shows the **brand or vendor name** of the SFP module.

- [Part Number](#)

This field shows the **model name (part number)** of the SFP module.

- [Transceiver Type](#)

This field shows the **transceiver type** of the SFP module including transmitting **speed** and the **type of fiber**. If there is no SFP module inserted or the transceiver type cannot be read, the field will show “**Unknown**”.

- [Laser Wavelength](#)

This field shows the **laser operating wavelength** of the SFP module.

- [Link Length](#)

This field shows the **maximum link length** of the SFP module.

DDM Module

Real-Time Value	
Temperature	57.000deg
Voltage	0.0mV
Current	0.000mA
Tx Power	0.0000mW
Rx Power	0.0000mW

Alarm Warning				
	HI ALARM	HI WARNING	LOW WARNING	LOW ALARM
TEMP	57.000deg	0.000deg	0.000deg	0.000deg
VOLT	1459.2mV	0.0mV	0.0mV	0.0mV
CURR	29.184mA	0.000mA	0.000mA	0.000mA
TX PW	1.4592mW	0.0000mW	0.0000mW	0.0000mW
RX PW	1.4592mW	0.0000mW	0.0000mW	0.0000mW

- [DDM Module](#)

This section only shows when the **SFP DDM** is supported on the inserted SFP module.

- [Real Time Value](#)

The current operating information including **temperature, voltage, current, Tx power, and Rx power**.

- [Alarm Warning](#)

The default configured threshold for triggering the alarm and system warning. There are 5 types of information (**temperature, voltage, current, Tx power, and Rx power**) and 4 levels of alarm and warning (**high alarm/warning, low alarm/warning**).

DETAILED PORT STATUS

There are two methods to link to **detailed port status (RMON)**. One is from **menu** and the other is from the **front panel** picture. Users can directly click the port on the front panel and then the page will redirect to the detailed port status page of the specific port. The RMON is a set of standard Simple Network Management Protocol (SNMP) and it is useful to monitor and manage the incoming and outgoing traffic.

Detailed Port Status

Port 1

→ Received Packets

Rx Octets	210214768
Rx Unicast	0
Rx Multicast	431649
Rx Broadcast	1391
Rx Pause	0

→ Received Size Counter

Rx 64 Bytes	512514
Rx 65-127 Bytes	9572
Rx 128-255 Bytes	35690
Rx 256-511 Bytes	433090
Rx 512-1023 Bytes	19
Rx 1024-1518 Bytes	57136

→ Received Error Counter

Rx Collision	0
Rx CRC/Alignment	0
Rx Drop	0
Rx Fragment	0
Rx Jabber	0
Rx Oversize	0
Rx Undersize	0

← Transmitted Packets

Tx Octets	108301443
Tx Unicast	17
Tx Multicast	531719
Tx Broadcast	83245
Tx Pause	0

← Transmitted Error Counter

Tx Discard	0
Tx Error	0

- [Port Selector](#)

Select the port number to monitor the RMON information.

Port 1 to N, where N is based on the total port number.

- **Received Packets**
 - **Rx Octets**: the total received traffic in bytes
 - **Rx Unicast**: the number of received unicast packets
 - **Rx Multicast**: the number of received multicast packets
 - **Rx Broadcast**: the number of received broadcast packets
 - **Rx Pause**: the number of MAC Control packets received on the specific interface with an opcode indicating the PAUSE operation.
- **Received Size Counter**
 - **Rx 64 Bytes**: the number of received packets that were 64 octets
 - **Rx 65-127 Bytes**: the number of received packets that were from 65 to 127 octets
 - **Rx 128-255 Bytes**: the number of received packets that were from 128 to 255 octets
 - **Rx 256-511 Bytes**: the number of received packets that were from 256 to 511 octets
 - **Rx 512-1023 Bytes**: the number of received packets that were from 512 to 1023 octets
 - **Rx 1024-1518 Bytes**: the number of received packets that were from 1024 to 1518 octets
- **Received Error Counter**
 - **Rx Collision**: the total number of collisions on the Ethernet segment.
 - **Rx CRC/Alignment**: the total number of received packets that have either a bad Frame Check Sequence (FCS) with an integral number of octets (FCS Error) or a bad FCS with a non-integral number of octets (Alignment Error).
 - **Rx Drop**: the total number of dropped packets due to lack of resources.
 - **Rx Fragment**: the total number of received packets that are less than 64 octets and had either a bad Frame Check Sequence (FCS) with an integral number of octets (FCS Error) or a bad FCS with a non-integral number of octets (Alignment Error).
 - **Rx Jabber**: the total number of received packets that are longer than 1518 octets and had either a bad Frame Check Sequence (FCS) with an integral number of octets (FCS Error) or a bad FCS with a non-integral number of octets (Alignment Error).
 - **Rx Oversize**: the total number of received packets that are longer than 1518 octets.
 - **Rx Undersize**: the total number of received packets that are less than 64 octets.
- **Transmitted Packets**
 - **Tx Octets**: the total transmitted traffic in bytes.
 - **Tx Unicast**: the number of transmitted unicast packets
 - **Tx Multicast**: the number of transmitted multicast packets
 - **Tx Broadcast**: the number of transmitted broadcast packets
 - **Tx Pause**: the number of MAC Control packets transmitted on the specific interface with an opcode indicating the PAUSE operation.
- **Transmitted Error Counter**

- **Tx Discard**: the number of outbound packets which are chosen to be discarded even though no errors had been detected. One possible reason for discarding such a packet could be to free up buffer space.
- **Tx Error**: the number of outbound packets that could not be transmitted because of errors.

EEE STATUS

Energy-Efficient Ethernet (EEE) is a feature to save power when the link is idle, which means the port is linked up but there is no traffic on the link. The EEE function can be enabled or disabled by port

EEE Status

Port	State	TxIdleTime	TxWakeupTime	TxEventCount	TxDuration	RxEventCount	RxDuration	Enable
1	Disable	60	30	-1	-1	-1	-1	<input type="checkbox"/>
2	Disable	60	30	-1	-1	-1	-1	<input type="checkbox"/>
3	Disable	60	30	-1	-1	-1	-1	<input type="checkbox"/>
4	Disable	60	30	-1	-1	-1	-1	<input type="checkbox"/>
5	Disable	60	30	-1	-1	-1	-1	<input type="checkbox"/>
6	Disable	60	30	-1	-1	-1	-1	<input type="checkbox"/>
7	Disable	60	30	-1	-1	-1	-1	<input type="checkbox"/>
8	Disable	60	30	-1	-1	-1	-1	<input type="checkbox"/>

Auto Refresh

Refresh Rate: seconds 

- **Port**
Port 1 to N, where N is based on the total port number.
- **State**
Display the state, Enable or Disable, of EEE function.
- **TxIdleTime**
The TxIdleTime is the required time to enter the EEE low-power mode.
- **TxWakeupTime**
The TxWakeupTime is the required time to exit the EEE low-power mode.
- **TxEventCount**
The TxEventCount is the EEE Low Power Idle (LPI) event counter of Tx. This counter implies the number of times that the LPI mode has been enforced by EEE function on the transmitting side.
- **TxDuration**
The TxDuration is an LPI event duration on the transmitting path which is updated if the port is in the EEE LPI mode.

- RxEventCount**

The RxEventCount is the EEE LPI event counter of Rx. This counter implies the number of times that the LPI mode has been enforced by EEE function on the receiving side.
- RxDuration**

The RxDuration is an LPI event duration on the receiving path which is updated if the port is in the EEE LPI mode.
- Enable**

Select the specific ports or deselect the selected ports and then click the “**Apply Selected**” button to enable or disable the EEE function. Directly click “**Enable All**” to enable EEE function on all ports or “**Disable All**” to disable EEE function on all ports.

PORT STATUS

Port Status

Port	Link Status	Speed	Duplex	Flow Control	Rx Byte	Tx Byte	PoE	Clear Rx/Tx
1	Up	1000	Full	Off	1704675	33021829	No_PD	<input type="checkbox"/>
2	Up	100	Full	Off	17960092	13197836	Delivery	<input type="checkbox"/>
3	Down	-	-	Off	0	0	No_PD	<input type="checkbox"/>
4	Up	100	Full	Off	5927919	25182558	Delivery	<input type="checkbox"/>
5	Up	1000	Full	Off	1175481	31105465	No_PD	<input type="checkbox"/>
6	Down	-	-	Off	0	0	No_PD	<input type="checkbox"/>
7	Up	1000	Full	Off	3192398	28409537	No_PD	<input type="checkbox"/>
8	Down	-	-	Off	0	0	No_PD	<input type="checkbox"/>
9	Down	-	-	Off	0	0	None	<input type="checkbox"/>
10	Down	-	-	Off	0	0	None	<input type="checkbox"/>
11	Down	-	-	Off	0	0	None	<input type="checkbox"/>
12	Down	-	-	Off	0	0	None	<input type="checkbox"/>

Auto Refresh

Refresh Rate: seconds 

- Port**





Port 1 to N, where N is based on the total port number.
- Link Status**

Link Status displays the link state (“Up” or “Down”) of the port. If the port is disabled, it displays “Disabled”.

- [Speed](#)
Speed displays the access speed in bit per second of the port. If the port is linked down, it displays “-”.
- [Duplex](#)
Duplex displays the link-type (Full or Half) of the port. If the port is linked down, it displays “-”.
- [Flow Control](#)
It is the state (On or Off) of the Flow Control.
- [Rx Byte](#)
This is the total **received** frames formatted in byte.
- [Tx Byte](#)
This is the total **transmitted** frames formatted in byte.
- [PoE \(PoE Model Only\)](#)
PoE displays the PoE state (Delivery, No PD, Disabled, None) of the port. If the port does not support PoE function, it displays “None”.
Note: This information is displayed on the system that supports the PoE function.
- [Clear Rx/Tx](#)
Select the specific ports and click the “**Click Selected**” button to clear the Tx/Rx Byte information or click “**Click All**” button to clear all ports’ Tx/Rx Byte information.

PORT RATE LIMIT

Port Rate Limit

Port	Ingress Limit 	Unit	Egress Limit 	Unit
1	<input type="text" value="500"/> 	Mbps	<input type="text" value="200"/> 	Mbps
2	<input type="text" value="0"/>	Mbps	<input type="text" value="0"/>	Mbps
3	<input type="text" value="0"/>	Mbps	<input type="text" value="0"/>	Mbps
4	<input type="text" value="0"/>	Mbps	<input type="text" value="0"/>	Mbps
5	<input type="text" value="0"/>	Mbps	<input type="text" value="0"/>	Mbps
6	<input type="text" value="0"/>	Mbps	<input type="text" value="0"/>	Mbps
7	<input type="text" value="0"/>	Mbps	<input type="text" value="0"/>	Mbps
8	<input type="text" value="0"/>	Mbps	<input type="text" value="0"/>	Mbps
9	<input type="text" value="0"/>	Mbps	<input type="text" value="0"/>	Mbps
10	<input type="text" value="0"/>	Mbps	<input type="text" value="0"/>	Mbps
11	<input type="text" value="0"/>	Mbps	<input type="text" value="0"/>	Mbps
12	<input type="text" value="0"/>	Mbps	<input type="text" value="0"/>	Mbps

Apply

- Port**
Port 1 to N, where N is based on the total port number.
- Ingress Limit**
Ingress Rate limit. Rate unit is in 1M bits per second. Range is from 1Mbps to maximum speed of the port. Value 0 means disabled.
- Egress Limit**
Egress Rate limit. Rate unit is in 1M bits per second. Range is from 1Mbps to maximum speed of the port. Value 0 means disabled.

IGMP / MLD Snooping

Internet Group Management Protocol (IGMP) and **Multicast Listener Discovery (MLD)** are used in communicating among hosts and establishing a multicast group membership on the IP networks (Layer 3). IGMP provides IPv4 network and MLD provides IPv6 network the ability to prune **multicast traffic** to those who need this kind of traffic and reduce the amount of traffic on the network. However, switches work on the MAC Layer (Layer 2) and are unable to obtain IGMP or MLD information. **IGMP Snooping** and **MLD Snooping** allow the switch to listen to the IGMP or MLD communication between hosts and routers, and maintains a table of multicast IPs and group members. **IGMP Snooping** and **MLD Snooping** can prevent the hosts on the LAN from receiving traffic from a non-joined multicast group and save bandwidth of the network.

CONFIGURE IGMP / MLD SNOOPING INFORMATION

⚙️ IGMP Snooping Settings

📍 Basic Settings

Mode	<input checked="" type="radio"/> Enable <input type="radio"/> Disable	
Last-Member Count	<input type="text" value="2"/>	?
Last-Member Interval	<input type="text" value="1"/>	?

📍 Fast-Leave Settings

Port	Fast-Leave Mode
1	<input type="radio"/> Enable <input checked="" type="radio"/> Disable
2	<input type="radio"/> Enable <input checked="" type="radio"/> Disable
3	<input type="radio"/> Enable <input checked="" type="radio"/> Disable
4	<input type="radio"/> Enable <input checked="" type="radio"/> Disable
5	<input type="radio"/> Enable <input checked="" type="radio"/> Disable
6	<input type="radio"/> Enable <input checked="" type="radio"/> Disable
7	<input type="radio"/> Enable <input checked="" type="radio"/> Disable
8	<input type="radio"/> Enable <input checked="" type="radio"/> Disable
9	<input type="radio"/> Enable <input checked="" type="radio"/> Disable
10	<input type="radio"/> Enable <input checked="" type="radio"/> Disable
11	<input type="radio"/> Enable <input checked="" type="radio"/> Disable
12	<input type="radio"/> Enable <input checked="" type="radio"/> Disable

Apply

⚙️ MLD Snooping Settings

📍 Basic Settings

Mode	<input checked="" type="radio"/> Enable <input type="radio"/> Disable	
Last-Member Count	<input type="text" value="2"/>	?
Last-Member Interval	<input type="text" value="1"/>	?

📍 Fast-Leave Settings

Port	Fast-Leave Mode ?
1	<input type="radio"/> Enable <input checked="" type="radio"/> Disable
2	<input type="radio"/> Enable <input checked="" type="radio"/> Disable
3	<input type="radio"/> Enable <input checked="" type="radio"/> Disable
4	<input type="radio"/> Enable <input checked="" type="radio"/> Disable
5	<input type="radio"/> Enable <input checked="" type="radio"/> Disable
6	<input type="radio"/> Enable <input checked="" type="radio"/> Disable
7	<input type="radio"/> Enable <input checked="" type="radio"/> Disable
8	<input type="radio"/> Enable <input checked="" type="radio"/> Disable
9	<input type="radio"/> Enable <input checked="" type="radio"/> Disable
10	<input type="radio"/> Enable <input checked="" type="radio"/> Disable
11	<input type="radio"/> Enable <input checked="" type="radio"/> Disable
12	<input type="radio"/> Enable <input checked="" type="radio"/> Disable

Apply

For more information, hover the mouse over the ? icon in the system.

- **Basic Setting**

- **Mode**

“Enable” or “Disable” the IGMP Snooping or MLD Snooping function.

- **Last-Member Count**

The count is the number of times that the router sends IGMP or MLD query messages to receive the leave message.

The range of the **Last-Member Count** is **from 2 to 10**.

The default **Last-Member Count Interval** is **2**.

- **Last-Member Interval**

The interval is the period to send IGMP or MLD query messages.

The range of the **Last-Member Interval** is **from 1 to 25** seconds.

The default Last-Member Interval is 1 second.

- **Fast-Leave Setting**

- Port

- Port 1 to N, where N is based on the total port number.

- Fast-Leave Mode

- “Enable” or “Disable” the fast-leave function on the specific port. If the fast-leave mode is enabled on the port, the switch will close the multicast stream when receiving a leave message on this port without further action.

- **Apply** (Apply Button)

After configuring above fields, click "**Apply**" button to make the changes effective.



CONFIGURE IGMP SNOOPING QUERIER INFORMATION

IGMP Snooping Querier

Basic Settings

Mode	<input type="radio"/> Enable <input checked="" type="radio"/> Disable
Query Interval	<input type="text" value="125"/>
Max Response Time	<input type="text" value="10"/>

Query Version Settings

VLAN ID 	State	Version	
<input type="text" value="1"/>	<input type="text" value="Enable"/>	<input type="text" value="v2"/>	

Apply

MLD Snooping Querier

Basic Settings

Mode	<input type="radio"/> Enable <input checked="" type="radio"/> Disable
Query Interval	125 ?
Max Response Time	10 ?

MLD Query Version Settings

VLAN ID ?	State	Version	
1	Enable ▼	v1 ▼	+ ×

Apply

For more information, hover the mouse over the ? icon in the system.

- **Basic Settings**

- **Mode**

“Enable” or “Disable” the IGMP Snooping or MLD Snooping Querier function. If it is enabled, the system sends IGMP snooping **version 1 and 2** queries or MLD snooping **version 1** queries.

- **Querier Interval**

This period is the interval to send the IGMP snooping or MLD snooping queries.

The range of the **Querier Interval** is **from 1 to 3600** seconds.

The default **Querier Interval** is **125** seconds.

- **Query Max Response Time**

This is a timer to wait for the member response of the IGMP or MLD groups. It is used in **removing** the information of the IGMP or MLD groups if no member responds to the query.

- **Query Version Settings**

The Query Version Settings is configured for per-VLAN query.

- **VLAN ID**

The field is to fill in the VLAN ID to configure the IGMP Snooping or MLD Snooping query version.

- **State**

“Enable” or “Disable” the IGMP Snooping or MLD Snooping query on the configured VLAN ID.

- **Version**

Set the IGMP Snooping version (v1, v2c, v3) or MLD Snooping on the specific VLAN.

- **Apply** (Apply Button)

After configuring above fields, click "**Apply**" button to make the changes effective.

CONFIGURE UNKNOWN MULTICAST INFORMATION

Unknown Multicast

Action Setting

Unknown-Multicast

Flooding

Router Port Settings

Port	Router Port	Status
1	<input type="checkbox"/>	-
2	<input type="checkbox"/>	-
3	<input type="checkbox"/>	-
4	<input type="checkbox"/>	-
5	<input type="checkbox"/>	-
6	<input type="checkbox"/>	-
7	<input type="checkbox"/>	-
8	<input type="checkbox"/>	-
9	<input type="checkbox"/>	-
10	<input type="checkbox"/>	-
11	<input type="checkbox"/>	-
12	<input type="checkbox"/>	-

Apply

- **Action Settings**
 - Unknown-Multicast
Configure the action when the system receives an unknown-multicast packet.
Flooding: flood the unknown-multicast packet to all other ports.
Discarding: discard the unknown-multicast packet.
Router: forward the unknown-multicast packet to the router port.
- **Router Port Settings**
 - No.
Port 1 to N, where N is based on the total port number.
 - Router Port
Set the specific port to router port or not.
 - Status
The status field shows the port's status which "-" implies not a router port and "static" implies set to router port.

IGMP SNOOPING TABLE

⚙️ IGMP Snooping Table

Show entries Search:

Multicast IP	Group
224.0.1.60	Port 5
239.255.255.250	Port 5

Showing 1 to 2 of 2 entries

Auto Refresh

Refresh Rate: seconds ?

⚙️ MLD Snooping Table

Show entries Search:

VLAN ID	Multicast IP	Group
1	ff02:0000:0000:0000:0000:0000:00ed	1
1	ff02:0000:0000:0000:0000:0000:00ee	1
1	ff02:0000:0000:0000:0000:0000:00ef	1
1	ff02:0000:0000:0000:0000:0000:00f0	1
1	ff02:0000:0000:0000:0000:0000:00f1	1
1	ff02:0000:0000:0000:0000:0000:000c	12
1	ff02:0000:0000:0000:0000:0000:00fb	12
1	ff02:0000:0000:0000:0000:0000:0001:0003	12
1	ff02:0000:0000:0000:0000:0000:0001:ff00:0001	12
1	ff02:0000:0000:0000:0000:0000:0001:ffb1:0f88	12

Showing 1 to 10 of 10 entries

Auto Refresh

Refresh Rate: seconds ?

- [Multicast IP](#)
The Multicast IP is the IP address of the multicast group.
- [Group](#)
The group shows the port number, which joined the group.

802.1Q VLAN

802.1Q VLAN

Virtual Local Area Network (VLAN) is a structure that can ease Network planning. The devices in a VLAN can be located anywhere without the restriction of physical connections, but work like they are on the same physical segment.

IEEE 802.1Q defines **VLAN tagging** conception for the Ethernet frames. VLAN tagging supports frames in the different VLAN groups transmitting on a link (called **VLAN trunk**). The maximum number of VLANs on the Ethernet network is 4096. The VLAN 0 and VLAN 4095 are for specific use and hence the usable VLAN number is **4094**.

VLAN Q-IN-Q

VLAN Q-in-Q, also called **Stacked VLAN**, is an extension for 802.1Q VLAN. It supports a maximum of 4096*4096 VLAN groups. VLAN Q-in-Q can apply a port to a provider, customer, or tunnel for different applications. The header of the stacked VLAN frame contains two 802.1Q Headers with different Ethertype (TPID). The TPID "0x88A8" is the outer tag by default and the TPID "0x8100" is the inner tag for 802.1Q VLAN. Customized ethertype called **Specific Provider Ethertype** are supported if one or more ports are set to "**Specific Provider**".





CONFIGURE 802.1Q VLAN INFORMATION

VLAN Settings

Management VLAN

VLAN ID	<input type="text" value="1"/>	
---------	--------------------------------	---

VLAN Member Settings

VLAN ID 	Name 	Untagged Ports	Tagged Ports	
<input type="text" value="1"/>	<input type="text" value="-"/>	12 items selected 	Nothing selected 	

For more information, hover the mouse over the  icon in the system.

- **Management VLAN**

- **VLAN ID**

The VLAN ID is for the native VLAN. Only the ports in the same VLAN as Management VLAN can **access the switch** configuration console via **Ethernet**.

The range of the VLAN ID is **from 1 to 4094**.

The default Management VLAN ID is **1**.

- [VLAN Member Settings](#)

- [VLAN ID](#)

Assigns a unique VLAN ID to this VLAN group.

The range of the VLAN ID is **from 1 to 4094**.

- [Name](#)

Assigns a name to this VLAN group to identify the different VLANs.

The **max. length** for the [Name](#) is **32 characters**.

Note: #, \, ', ", ? are **invalid** characters.

- [Untagged Ports](#)

Sets the untagged ports for this VLAN group. The system **removes the VLAN tag** before transmitting from the port that is set to “**untagged**”. Usually, this port is connected to the end device that belongs to this VLAN.

- [Tagged Ports](#)

Sets the tagged ports for this VLAN group. The system **keeps the VLAN tag** when transmitting from the port that is set to “**tagged**”. Usually this port is connected to another switch and uses the VLAN tag to transfer the VLAN information.

- **+**: Click the **plus icon** to add a VLAN Member row.

- **X**: Click the **remove icon** to delete the VLAN Member row.

802.1Q VLAN TABLE

VLAN Table

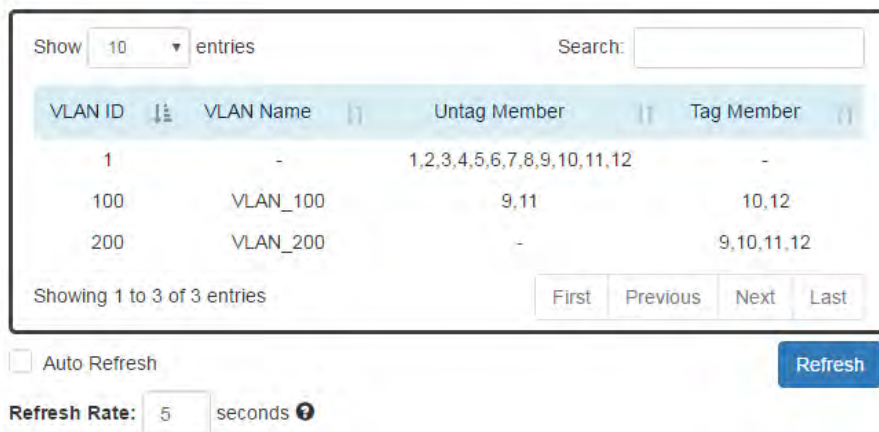

VLAN ID	VLAN Name	Untag Member	Tag Member
1	-	1,2,3,4,5,6,7,8,9,10,11,12	-
100	VLAN_100	9,11	10,12
200	VLAN_200	-	9,10,11,12

Showing 1 to 3 of 3 entries

Auto Refresh: Refresh Rate: 5 seconds

Refresh

- [VLAN ID](#)

This is the assigned unique **VLAN ID** for this VLAN group.

- [VLAN Name](#)

This is the assigned **VLAN Name** for this VLAN group.

- [Untag Member](#)

These ports are assigned as VLAN untagged ports.

- [Tag Member](#)

These ports are assigned as VLAN tagged ports.

CONFIGURE 802.1Q VLAN PVID & ACCEPT TYPE

VLAN PVID

Port	PVID
1	1
2	1
3	1
4	1
5	1
6	1
7	1
8	1
9	1
10	1
11	1
12	1

Accept Type

Port	Filter
1	All
2	All
3	All
4	All
5	All
6	All
7	All
8	All
9	All
10	All
11	All
12	All

For more information, hover the mouse over the icon in the system.

- [VLAN PVID](#)

- [Port](#)

Port1 to PortN, where N is based on the total port number.

- [PVID](#)

Assign a VLAN ID to the frames without a VLAN tag that come into the specific port.

- [Accept Type](#)

- [No.](#)

Port1 to PortN, where N is based on the total port number.

- [Filter](#)

Three types of filters are provided: All, Tagged Only, Untagged Only.

All: Accept both tagged and untagged frames that come into the port.

Tagged Only: Accept only tagged frames that come into the port.

Untagged Only: Accept only untagged frames that come into the port.

- (Apply Button)

After configuring the above fields, click "**Apply**" button to make it effective.

CONFIGURATION EXAMPLE FOR MANAGEMENT VLAN



Key Points

2. Implement VLAN 777 and apply only Lan7 to VLAN 777
3. Implement VLAN 123 and apply the ports which are connected to IP cameras
4. Assign Management VLAN to VLAN 777

Step-by-step Configuration

1. Login Web Console and click menu "L2 Switching" -> "802.1Q VLAN" -> "VLAN Settings"
2. Add rows for VLAN 123 and 777. Apply assigned ports (untagged) to the VLAN.
Why untagged? The connected devices are all hosts which are unable to deal with the VLAN tag, so we have to remove the VLAN tag when the frame is sending out through the port.

VLAN Member Settings

VLAN ID	Name	Untagged Ports	Tagged Ports	
1	-	12 items selected	Nothing selected	✕
123	IP Camera	Nothing selected	Nothing selected	✕
777	Management	Nothing selected	Nothing selected	✕

3. Configured the PVID for the applied ports.
The PVID of Port 1 to 5 is 123 and the PVID of Port 7 is 777.

VLAN PVID

Port	PVID
1	123 ✓
2	123 ✓
3	123 ✓
4	123 ✓
5	123 ✓
6	1
7	777 ✓
8	1
9	1
10	1
11	1
12	1

- Configure Management VLAN to VLAN 777

Management VLAN

VLAN ID

✓
?

- Click the “Apply” button to apply the above configurations.

Note: After applying the configurations, the user can only access the management interface via specific interface (in this case: Lan7).

CONFIGURE VLAN Q-IN-Q

Q-in-Q Settings

Specific Provider Ethertype

Ethertype

?

For more information, hover the mouse over the ? icon in the system.

- [Specific Provider Ethertype](#)

This is a global configuration and an Ethertype is assigned for all ports, which are configured as “**Specific Provider**”. This field is locked (disabled) until at least one port is configured to the “**Specific Provider**” in the “**Q-in-Q Port Settings**” section.

The range of the Provider Ethertype is from **0x0000** to **0xFFFF**, but **0x8100** is **invalid**.

The default Provider Ethertype is **0x88A8**.

Q-in-Q Port Settings

Port	Mode
1	Customer
2	Customer
3	Customer
4	Customer
5	Customer
6	Customer
7	Customer
8	Customer
9	Customer
10	Customer
11	Customer
12	Customer

Apply

- **Q-in-Q Port Settings**

- **Port**

Port1 to PortN, where N is based on the total port number.

- **Mode**

Set the port to one of the Q-in-Q mode.

The Egress is dependent on the connected device and hence the egress action is skipped.

Mode	Ingress
Q-in-Q Tunnel	Untagged Frames: Add TPID:0x88A8 tag and forward. Tagged Frames: <ol style="list-style-type: none"> 5. TPID:0x8100: Add TPID:0x88A8 tag and forward. 6. TPID:0x88A8: Forward the frames.
Mode	Ingress
Customer	A port set to "Customer" runs typically 802.1Q VLAN. Untagged Frames: Add TPID:0x8100 tag and forward. Tagged Frames: <ol style="list-style-type: none"> 1. TPID:0x8100: <ol style="list-style-type: none"> a. Same VLAN ID: Forward the frames. b. Different VLAN ID: Discard the frames. 2. TPID:0x88A8: Discard the frames.

Provider	<p>Untagged Frames: Add TPID:0x88A8 tag and forward.</p> <p>Tagged Frames:</p> <ol style="list-style-type: none"> 1. TPID:0x8100: Discard the frames. 2. TPID:0x88A8: <ol style="list-style-type: none"> a. Same VLAN ID: Forward the frames. b. Different VLAN ID: Discard the frames.
Specific Provider	<p>Users define the Ethertype for the Provider service.</p> <p>Untagged Frames: Add the user-defined TPID tag and forward.</p> <p>Tagged Frames:</p> <ol style="list-style-type: none"> 1. TPID:0x8100: Discard the frames. 2. TPID:0x88A8: Discard the frames. 3. TPID: [user-defined]: <ol style="list-style-type: none"> a. Same VLAN ID: Forward the frames. b. Different VLAN ID: Discard the frames.

-  (Apply Button)

After configuring above fields, click "**Apply**" button to make the changes effective.

Quality of Service

Quality of Service which known as **QoS** provides a stable and predictable transmitting service. It is useful to manage the bandwidth more efficiently based on the requirement of applications. Users are able to set **different priorities** for different traffics to satisfy the services which need a fixed bandwidth and have more sensitive of delay. **Quality of Service** can also optimize the restrict bandwidth resource and control the network traffic of the switches.









CONFIGURE QoS INFORMATION

QoS Settings

Queue Scheduling

Scheduling Mode	WRR (Weighted) ▼
-----------------	------------------

Queue Weight

Queue	Weight		Queue	Weight	
1	<input type="text" value="1"/>		5	<input type="text" value="5"/>	
2	<input type="text" value="2"/>		6	<input type="text" value="6"/>	
3	<input type="text" value="3"/>		7	<input type="text" value="7"/>	
4	<input type="text" value="4"/>		8	<input type="text" value="8"/>	

For more information, hover the mouse over the  icon in the system.

- [Queue Scheduling](#)
 - [Scheduling Mode](#)
Select the scheduling mode for the Quality of Service.
WRR: Weighted Round Robin. WRR ensures that every queue takes turns to transmit the traffic by its weight.
Strict: Strict Priority Queue. The traffic is transmitted based on the priority, which is from highest to lowest.
- [Queue Weight](#)
 - [Queue](#)
Eight queues from queue 0 to queue 7 are supported.
 - [Weight](#)
Enables you to configure a specific weight for the port.
The range of the Weight is **from 1 to 100**. There is no need to sum all queues to 100.
The default Weight for each queue is displayed in the table:

Queue	0	1	2	3	4	5	6	7
Weight	1	2	3	4	5	6	7	8

CONFIGURE QOS TRUST MODE AND DEFAULT COS

Trust Mode

Port	Mode
1	CoS
2	CoS
3	CoS
4	CoS
5	CoS
6	CoS
7	CoS
8	CoS
9	CoS
10	CoS
11	CoS
12	CoS

Default CoS

Port	Class
1	0
2	0
3	0
4	0
5	0
6	0
7	0
8	0
9	0
10	0
11	0
12	0

- **Trust Mode**
 - **Port**
Port1 to PortN, where N is based on the total port number.
 - **Mode**
CoS: Class of Service. Use the 3-bit “PRI” field in the VLAN tag. It enables you to assign traffic to 8 different classes **from 0 to 7**.
DSCP: Use 6-bit field “DSCP” in the Type of Service (ToS) tag. It enables you to assign traffic to 64 different types **from 0 to 63**.
- **Default CoS**
 - **Port**
Port1 to PortN, where N is based on the total port number.
 - **Class**
You can assign a default class to the port. The system follows the assigned CoS classes to transmit frames if there is **no VLAN tag** in the frame header.

The default Class for each port is **0**.

-  (Apply Button)

After configuring above fields, click "**Apply**" button to make the changes effective.

CONFIGURE COS MAPPING

CoS Mapping

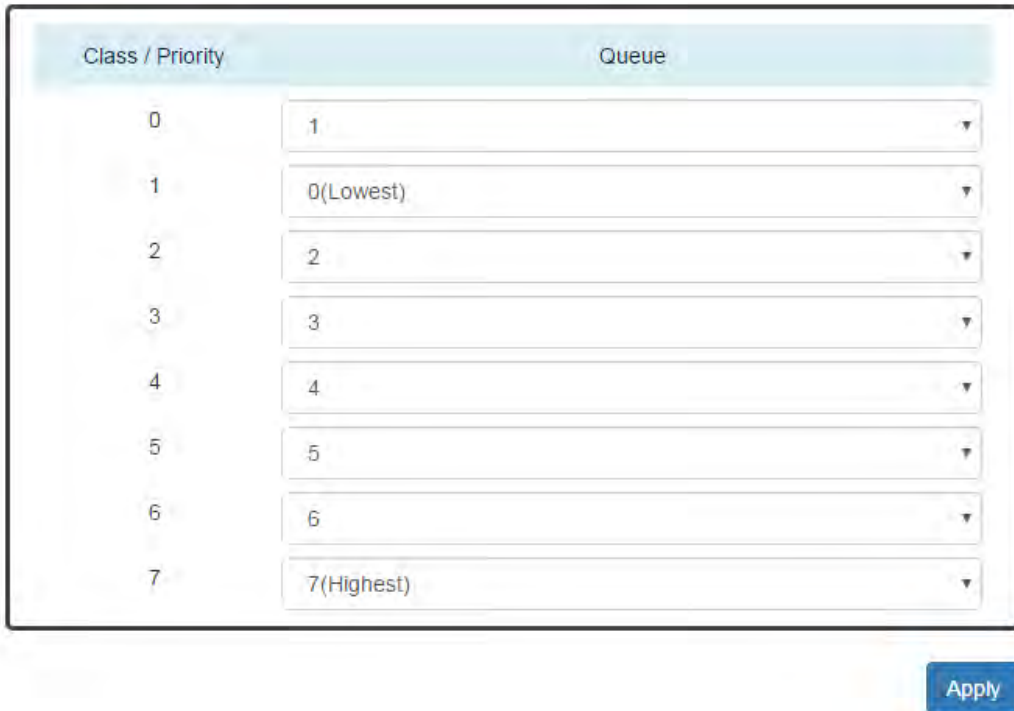

Class / Priority	Queue
0	1
1	0(Lowest)
2	2
3	3
4	4
5	5
6	6
7	7(Highest)



- [Class / Priority](#)

There are **3 bits** for the “Class of Service” field called “**PRI**” in the VLAN tag and there are 8 classes **from 0 to 7**.

- [Queue](#)

The chipset supports **8 queues from queue 0 to queue 7**. The queue 0 is the lowest priority queue and the queue 7 is the highest priority queue.

The default Queue for each class is displayed in the table:

Class	0	1	2	3	4	5	6	7
Queue	1	0	2	3	4	5	6	7

CONFIGURE TOS MAPPING

DSCP Mapping

DSCP	Queue	DSCP	Queue	DSCP	Queue	DSCP	Queue
0	0(Lov)	16	2	32	4	48	6
1	0(Lov)	17	2	33	4	49	6
2	0(Lov)	18	2	34	4	50	6
3	0(Lov)	19	2	35	4	51	6
4	0(Lov)	20	2	36	4	52	6
5	0(Lov)	21	2	37	4	53	6
6	0(Lov)	22	2	38	4	54	6
7	0(Lov)	23	2	39	4	55	6
8	1	24	3	40	5	56	7(Hig)
9	1	25	3	41	5	57	7(Hig)
10	1	26	3	42	5	58	7(Hig)
11	1	27	3	43	5	59	7(Hig)
12	1	28	3	44	5	60	7(Hig)
13	1	29	3	45	5	61	7(Hig)
14	1	30	3	46	5	62	7(Hig)
15	1	31	3	47	5	63	7(Hig)

Apply

- **DSCP**
There are **6 bits** for the “DSCP” in ToS tag and hence there are 64 classes **from 0 to 63**.
- **Queue**
The chipset supports **8 queues from queue 0 to queue 7**. The queue 0 is the least priority queue and the queue 7 is the highest priority queue.

The default Queue for each type is displayed in the table:

Type	0-7	8-15	16-23	24-31	32-39	40-47	48-55	56-63
Queue	0	1	2	3	4	5	6	7

- **Apply** (Apply Button)

After configuring above fields, click "**Apply**" button to make the changes effective.

Port Trunk

Port Trunk is also known as **Link Aggregation**, and it is a protocol to group links to a trunk. A total of **8** trunk groups are provided. It is a good method to reach load balance and link backup. For example, when port 1 to port 4 are combined to trunk 1 and all ports support 100Tx and set to full-duplex, the bandwidth of the trunk will be 800Mbps. The traffic transmitting on the trunk is distributed to one of the link by the source **MAC address** to reach the load balance. When the trunk mode is set to LACP and when one of the link is broken, the traffic will transmit on another link on the group.

CONFIGURE PORT TRUNK INFORMATION

Trunking Settings

Group	Trunking Mode	Member Ports
Trunk 1	LACP	Nothing selected
Trunk 2	LACP	Nothing selected
Trunk 3	LACP	Nothing selected
Trunk 4	LACP	Nothing selected
Trunk 5	LACP	Nothing selected
Trunk 6	LACP	Nothing selected
Trunk 7	LACP	Nothing selected
Trunk 8	LACP	Nothing selected

Apply

- **Group**
Eight trunk groups from **Trunk 1** to **Trunk 8** are supported.
- **Trunking Mode**
Two trunking modes are available: "LACP" and "Static".
Static: The traffic is transmitted on one of the links in the group. The link is determined by the MAC Address in the frame header. If the link is broken, the traffic cannot transmit on the other links in the group.

LACP: It is also known as “Dynamic” trunking. If the current transmitting link is broken, the traffic can be transmitted on another link in the group.

- **Member Ports**

Select member ports to be joined in the specified Trunk group. A port can only be in one of the Trunk group. Each Trunk group supports maximum 8 member per ports.

- **Apply** (Apply Button)

After configuring above fields, click "**Apply**" button to make the changes effective.

PORT TRUNK STATUS

Trunking Status

Group	Type	Ports	Link Status
Trunk 1	-	-	-
Trunk 2	-	-	-
Trunk 3	Static	9	Down
		10	Down
		12	Down
Trunk 4	-	-	-
Trunk 5	LACP	7	Down
		8	Down
Trunk 6	-	-	-
Trunk 7	-	-	-
Trunk 8	-	-	-

Auto Refresh **Refresh**

Refresh Rate: seconds 

- **Group**

The supported trunk groups are from **Trunk 1** to **Trunk 8**.

- **Type**

The trunk mode set for this group may be “**LACP**” or “**Static**”. This field displays “-” if no members are in the group.

- **Ports**

The selected member ports in the group will be displayed in this column.

- **Link Status**

This field displays the link state (Up or Down) for the specific port.

Voice VLAN

Configuring the Voice VLAN can improve Voice over IP (VoIP) service quality. IP voice traffic transmitting from IP phones are going to transfer to the specific VLAN. Voice VLAN provides Quality of Service (QoS) to have limited latency that ensure the quality of the call.

Using the **Extended ACL Configuration** can apply the configure of Voice VLAN. This is a example about the Voice VLAN configuration.

CONFIGURE VOICE VLAN INFORMATION

Extended ACL Configuration



ACL Entry ID: 1

ACL Action: Priority 7

ACL Qualifier: [Empty field]

Buttons: Set, Apply

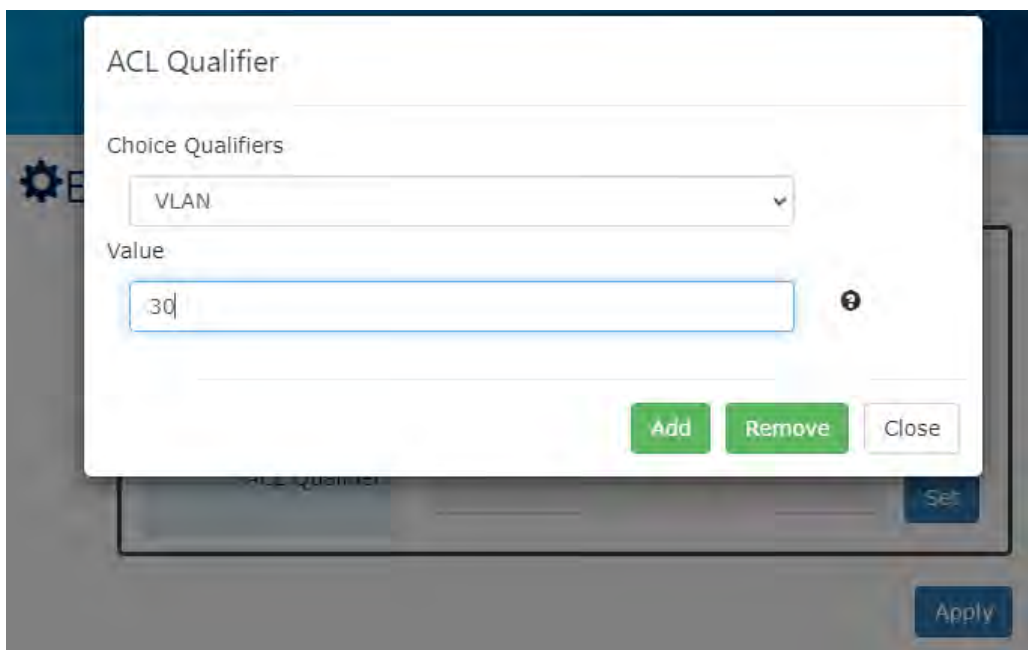

ACL Qualifier

Choice Qualifiers: VLAN

Value: 30

Buttons: Add, Remove, Close

- [ACL Entry ID](#)

Entry number in the ACL table. The range of the Index is from **1 to 128**

- [ACL Action](#)

Select **Priority**, fill in priority level with **7**.

- [ACL Qualifier](#)

 (Set Button)

After click the "Set" button, it is going to appear the ACL Qualifier window.

Choice Qualifier: Select "VLAN"

Value: Assign the ID of the Voice VLAN

 (Add Button)

-  (Apply Button)

After configuring above fields, click "**Apply**" button to make the changes effective.

Storm Control

A traffic storm happens when there is excessive packets **flood** to the LAN and decreases the performance. The **Storm Control** function is used to prevent the system from breaking down by the broadcast, multicast, or unknown unicast traffic storm. When the **Storm Control** is enabled on the specific traffic type, the system will monitor the incoming traffic. If the traffic is more than the configured level, the traffic will be dropped to avoid the storm.

CONFIGURE STORM CONTROL INFORMATION

Storm Control

Traffic Type	Mode	Level
Broadcast	<input type="radio"/> Enable <input checked="" type="radio"/> Disable	High (2500fps) ▼
Multicast	<input type="radio"/> Enable <input checked="" type="radio"/> Disable	High (2500fps) ▼
Unknown Unicast	<input type="radio"/> Enable <input checked="" type="radio"/> Disable	High (2500fps) ▼

[Apply](#)

- Traffic Type**

Three types of traffics are supported in the Storm Control: **Broadcast**, **Multicast**, and **Unknown Unicast**.
- Mode**

“Enable” or “Disable” Storm Control function in the specific traffic type.
- Level**

Three frame levels are available: **High**, **Middle**, and **Low**. If the frames of specific traffic type are more than the set level, the system will drop the type of frames to prevent the system from breaking down.

High: More than 2500 frame per second.
Mid: More than 1000 frame per second.
Low: More than 500 frame per second.
-  (Apply Button)

After configuring above fields, click "**Apply**" button to make the changes effective.

802.1X Settings

802.1X is an **IEEE** standard defined **Port-based Network Access Control**. It provides a more secured authentication mechanism for the devices, which would like to connect to a LAN or a WAN. The **Port-based** Network Access Control protocol is a convenient method for the users because the authentication is per-port and once the port passes the authentication, it is not required to authenticate again when changing to another device, i.e., without security. Therefore, **MAC-based** access control is provided. It is a more secure, but less convenient method for authentication. Only the device with the MAC Address that has passed the authentication can be added to the networks. These two methods are optional on each port and the users can select one of them on different ports.

CONFIGURE 802.1X BASIC INFORMATION

802.1X Settings

Basic Settings



For more information, hover the mouse over the  icon in the system.

- Basic Settings

- 802.1X Mode

“Enable” or “Disable” 802.1X function on the switch.

- Server Type

Select the 802.1X server type to “Local Database” or “RADIUS Server”.

Local Database: The database is maintained in a table stored in the switch. The client has to send the username and password to authenticate with the switch’s database.

RADIUS Server: The database is maintained in other devices running RADIUS service. The authentication follows the RADIUS protocol including communication and encryption.

CONFIGURE 802.1X PORT INFORMATION

📍 Port Settings

Port	Enable	Mode	Re-Auth	Re-Auth Period 
1	No ▾	Multi 802.1 ▾	No ▾	period: <input type="text"/>
2	No ▾	Multi 802.1 ▾	No ▾	period: <input type="text"/>
3	No ▾	Multi 802.1 ▾	No ▾	period: <input type="text"/>
4	No ▾	Multi 802.1 ▾	No ▾	period: <input type="text"/>
5	No ▾	Multi 802.1 ▾	No ▾	period: <input type="text"/>
6	No ▾	Multi 802.1 ▾	No ▾	period: <input type="text"/>
7	No ▾	Multi 802.1 ▾	No ▾	period: <input type="text"/>
8	No ▾	Multi 802.1 ▾	No ▾	period: <input type="text"/>
9	No ▾	Multi 802.1 ▾	No ▾	period: <input type="text"/>
10	No ▾	Multi 802.1 ▾	No ▾	period: <input type="text"/>
11	No ▾	Multi 802.1 ▾	No ▾	period: <input type="text"/>
12	No ▾	Multi 802.1 ▾	No ▾	period: <input type="text"/>

For more information, hover the mouse over the  icon in the system.

- **Port Settings**
 - **Port**
Port1 to PortN, where N is based on the total port number.
 - **Enable**
Yes: Enable 802.1x authentication on this port, un-authenticated traffic transmissions are blocked.
No: Disable 802.1x authentication on this port, allows to send and receive traffic without 802.1x authentication of the attached client.
 - **Mode**
Port-based: Only one of the attached clients on this port needs to authenticate. After it is authorized, all other clients connected to this port are granted network access.
Multi 802.1X: Every attached client on this port requires authentication individually.

- [Re-Auth](#)

“Enable” or “Disable” re-authentication on the port. “Yes” means re-authentication is enabled on the port and the port has to re-authenticate with the server every re-auth period.

- [Re-Auth Period](#)





This is a time interval, which is used in re-authenticating the server.

-  (Apply Button)

After configuring above fields, click "**Apply**" button to make the changes effective.

CONFIGURE LOCAL DATABASE INFORMATION

Local Database

User Name 	Password 	Confirm Password 	
<input type="text"/>	<input type="password"/>	<input type="password"/>	



For more information, hover the mouse over the  icon in the system.

- [User Name](#)

The User Name is used in authentication.

The **max. length** for the User Name is **32 characters**.

Note: #, \, ', ", ? are **invalid** characters.

- [Password](#)



The Password is used in authentication.

The **max. length** for the Password is **20 characters**.

Note: #, \, ', ", ? are **invalid** characters.

- [Confirm Password](#)

The Confirm Password field must be the same as Password field.



- : Click the **plus icon** to add a Username/Password row.
- : Click the **remove icon** to delete the Username/Password row.
-  (Apply Button)

After configuring above fields, click "**Apply**" button to make the changes effective.



CONFIGURE RADIUS SERVER INFORMATION

 **RADIUS Server**

 **RADIUS Server 1**

Server IP	<input type="text" value="127.0.0.1"/>	
Service Port	<input type="text" value="1812"/>	
Shared Key	<input type="password" value="....."/>	

 **RADIUS Server 2**

Server IP	<input type="text" value="127.0.0.1"/>	
Service Port	<input type="text" value="1812"/>	
Shared Key	<input type="password" value="....."/>	



For more information, hover the mouse over the  icon in the system.

- [Server IP](#)
The Server IP is the IP address of the server.
- [Service Port](#)
The Service Port is the listening port on the RADIUS server.
- [Shared Key](#)
The key is used in establishing the connection between the server and the authenticator before authentication.
-  (Apply Button)
After configuring above fields, click "**Apply**" button to make the changes effective.

Service Control

We provide 5 types of interface which are **HTTP**, **HTTPS**, **SSH**, **Telnet**, and **Console Port** to access the management interface of the switch. Users can configure the authority for each type of service to be enabled or disabled. **Reset Button** is another method to reboot or reset factory default. We also provide the configuration for the Reset Button to enable or disable its function. All of the services are enabled by default and users can disable unused service to make the system more secure.

CONFIGURE SERVICE CONTROL INFORMATION

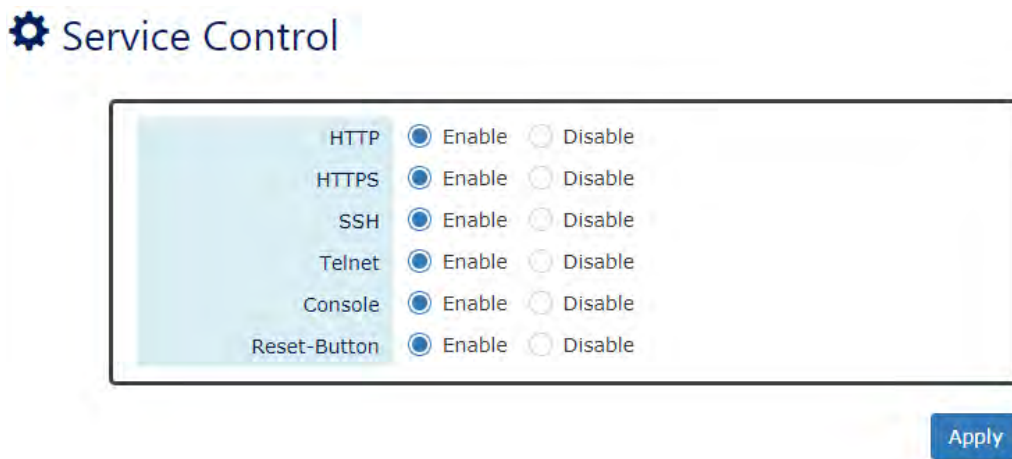

- [HTTP](#)**

Enable or Disable to access management interface by **HTTP** which is the foundation of data communication for the **World Wide Web (WWW)**.
- [HTTPS](#)**

Enable or Disable to access management interface by **HTTPS** which is an adaptation of HTTP for security. The communication will be **encrypted** in HTTPS.
- [SSH](#)**

Enable or Disable to access management interface by **SSH**, which is a **cryptographic network** protocol. SSH provides a **secure channel** over an unsecured network in the client-server architecture. The switch plays the role of SSH server and hosts plays the role of SSH client.
- [Telnet](#)**

Enable or Disable to access management interface by **Telnet** which is a **text-oriented** virtual terminal connection. It's less secure than SSH because it doesn't encrypt any data even password when the data is transmitting.
- [Console](#)**

Enable or Disable to access management interface by **Serial Console Port**. Disable the Console Port can avoid the misconfiguration by someone who can access the device on-site.

- [Reset Button](#)

Enable or Disable to react when users press the **Reset Button**. The Reset Button provides different functions including reboot and reset factory default. Disable Reset Button is a protection from mistaking the button to reboot the system or restore the system to default state.

-  (Apply Button)

After configuring above fields, click "**Apply**" button to make the changes effective.

Access Control List

An access control list is a list of rules associated with a switch fabric. An ACL specifies which packet takes specific action to transfer to destination port. There are two kinds of ACL group, Basic and Extended.

Standard ACL provides rules to apply all network ports. The inbound traffic checked the entries in the ACL table. Each entry can be the MAC entry for layer 2 address and IP entry for the layer 3 address. And it can check the source address or destination address. User can adjust the address mask to provide the group setting in one entry. Entry has two actions that can permit or deny network packet transmitting to another port.

CONFIGURE STANDARD ACCESS CONTROL LIST

```
Switch(config)# acl mac
Usage: acl mac [Entry ID] [drop|permit] [SrcMac|DstMac] [Mac] [Wildcard]
```

```
Switch(config)# acl ip
Usage: acl ip [Entry ID] [drop|permit] [SrcIp|DstIp] [IP] [Wildcard]
```

- [Index](#)
Entry number in the ACL table. Traffic packet will be checked with the index sequence.
The range of the [Index](#) is from **1 to 128**
- [Action](#)
Drop: Packet will discarded if it hit the address rule.
Permit: Packet will forwarded if it hit the address rule.
- [Address Type](#)
Src: Address rule bases on the source address
Dst: Address rule bases on the destination address
- [Address](#)
MAC address with byte colon format. For example: 00:80:C2:01:23:45
IP Address with decimal dot format. For example: 192.168.1.123
- [Wildcard Mask](#)
A wildcard mask is a mask of bits that indicates which parts of an IP or MAC address are available for examination. A wild card mask is a matching rule. The rule for a wildcard mask is:

- 0 means that the equivalent bit must match
- 1 means that the equivalent bit does not matter

Bit mask for MAC address with byte colon. Bit 0 is checking the rule. Otherwise bit 1 is excluded in the checking rule.

Subnet mask for IP address with decimal dot. To decide the type of network

Extended ACL provides advance rules to apply enhance action. The inbound traffic checked the entries of qualifier. Entry of qualifier can be the ether-type, VLAN, QoS, MAC entry for layer 2 header, IP entry for the layer 3 address, TCP/UDP port for the layer 4. There are 4 kinds of actions for extended ACL, drop, permit, redirect interface and priority modified.

CONFIGURE EXTENDED ACCESS CONTROL LIST

Extended ACL Configuration

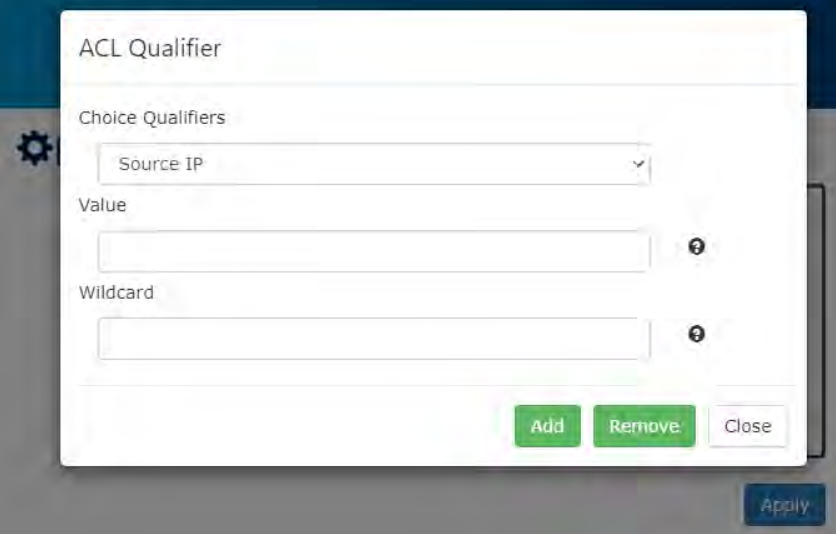
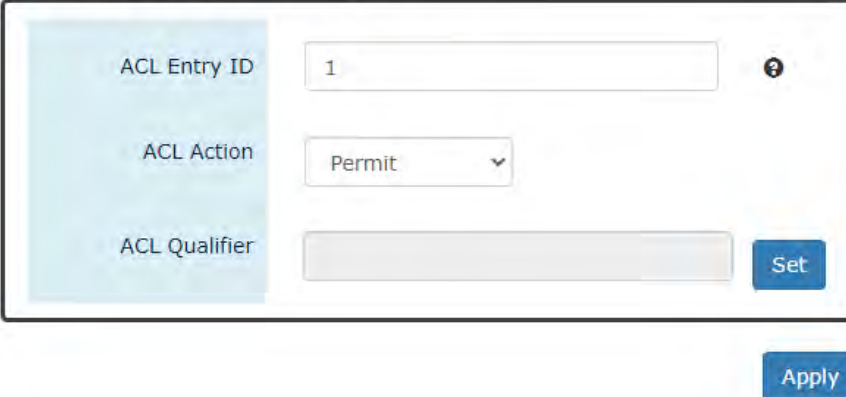

CLI COMMAND

```
Switch(config)# acl extended
Usage: acl extended [Entry ID: 1 - 128]

Switch(config)# acl extended 1
```

- [Index](#)

Entry number in the ACL table. Traffic packet will be checked with the index sequence.

The range of the [Index](#) is from **1 to 128**

User are going to enter the extended ACL interface with the index “**ext-aclx**”.

Extended ACL has qualifier that can apply complex rule for the entry. It can have multiple rules in a qualifier. An entry will take action when all rules match in the qualifier. In the other word, qualifier take AND algorithm for several rule apply.

After setting qualifier and action, entry request ENABLE command to make it works. User can take DISABLE command for unapplied and keep the setting.

```
Switch(config-ext-acl1)# qualifier dstip
Usage: qualifier dstip [IP_ADDR] [WILDCARD]

Switch(config-ext-acl1)# qualifier dstmac
Usage: qualifier dstmac [MAC_ADDR] [WILDCARD]
e.g. qualifier dstmac 00:11:22:33:44:55 00:00:00:FF:FF:FF

Switch(config-ext-acl1)# qualifier dstport
Usage: qualifier dstport [1 - 65535]

Switch(config-ext-acl1)# qualifier ethertype
Usage: [0x0 - 0xFFFF]

Switch(config-ext-acl1)# qualifier interface
Usage: qualifier interface [1 - 12]

Switch(config-ext-acl1)# qualifier qos
Usage: qualifier qos [0 - 7]

Switch(config-ext-acl1)# qualifier srcip
Usage: qualifier srcip [IP_ADDR] [WILDCARD]

Switch(config-ext-acl1)# qualifier srcmac
Usage: qualifier srcmac [MAC_ADDR] [WILDCARD]
e.g. qualifier srcmac 00:11:22:33:44:55 00:00:00:FF:FF:FF

Switch(config-ext-acl1)# qualifier srcport
Usage: qualifier srcport [1 - 65535]

Switch(config-ext-acl1)# qualifier vlan
Usage: [1 - 4094]
```

- [Qualifier](#)

Destination IP (dstip): Destination IP address. IP Address forms of decimal dot format. For example: 192.168.1.123. A wild card mask is a matching rule. Bit 0 is checking the rule. Otherwise bit 1 is excluded in the checking rule. For example: 0.0.0.255 checks the 24bits of the highest bit.

Destination MAC (dstmac): Destination MAC address. MAC address forms of byte colon format. For example: 00:80:C2:01:23:45. A wild card mask is a matching rule. Bit 0 is checking the rule. Otherwise bit 1 is excluded in the checking rule. For example: 00:00:00:00:ff:ff checks the 32bits of the highest bit.

Destination Port (dstport): Destination TCP/UDP port number. The range of the port is from **1 to 65535**

Ether Type (ethertype): EtherType filed of MAC header. It has 2 bytes. Format in hex **0x0000~0xFFFF**.

Interface (interface): Interface number of incoming packet.

QoS (qos): Class of Service (CoS) or Priority Code Point (PCP) filed of MAC header. The range of the qos is from **0 to 7**

Source IP (srcip): Source IP address. IP Address forms of decimal dot format. A wild card mask is a matching rule. Bit 0 is checking the rule. Otherwise bit 1 is excluded in the checking rule.

Source MAC (srcmac): Source MAC address. MAC address forms of byte colon format. A wild card mask is a matching rule. Bit 0 is checking the rule. Otherwise bit 1 is excluded in the checking rule.

Source Port (srcport): Source TCP/UDP port number. The range of the port is from **1 to 65535**.

VLAN (vlan): VLAN ID of the incoming packet. The range of the vlan is from **1 to 4094**.

```
Switch(config-ext-acl)# action
Usage: action [drop|permit|redirect [interface]|priority [qos]]
```

- [Action](#)

Drop: Packet will discard if it hit the address rule.

Permit: Packet will be forwarded if it hit the address rule.

Redirect: Packet outgoing will redirect to the specific interface if it hit the qualifier rule.

Priority: Packet will send the specific priority queue if it hit the qualifier rule. The range of the qos is from **0 to 7**.

- [Vaule](#)

The value is going to apply to the qualifier.

- [Wildcard](#)

A wildcard mask is a mask of bits that indicates which parts of an IP or MAC address are available for examination. A wild card mask is a matching rule. The rule for a wildcard mask is:

```
Switch(config-ext-acl1)# enable
enable Enable Extended ACL entry

Switch(config-ext-acl1)# disable
disable Disable Extended ACL entry
```

- [Enable](#)

Enable the extended ACL entry.

- [Disable](#)

Disable the extended ACL entry.

One status page can check all rules that apply to the switch.

Extended ACL Status

Entry ID	Action	Qualifier	Edit	Remove
1	Permit	Src IP 192.168.10.30 0.0.0.0		
10	Permit	Src Port 5000		
20	Permit	Src IP 192.168.10.90 0.0.0.0		
120	Drop	Src IP 0.0.0.0 255.255.255.255		

Showing 1 to 4 of 4 entries

First Previous Next Last

ACCESS CONTROL LIST EXAMPLE

Admin's PC

MAC Address: 68:02:35:FF:AB:01

IP Address: 192.168.1.99

Scenario 1

Only allow Admin's PC to access database

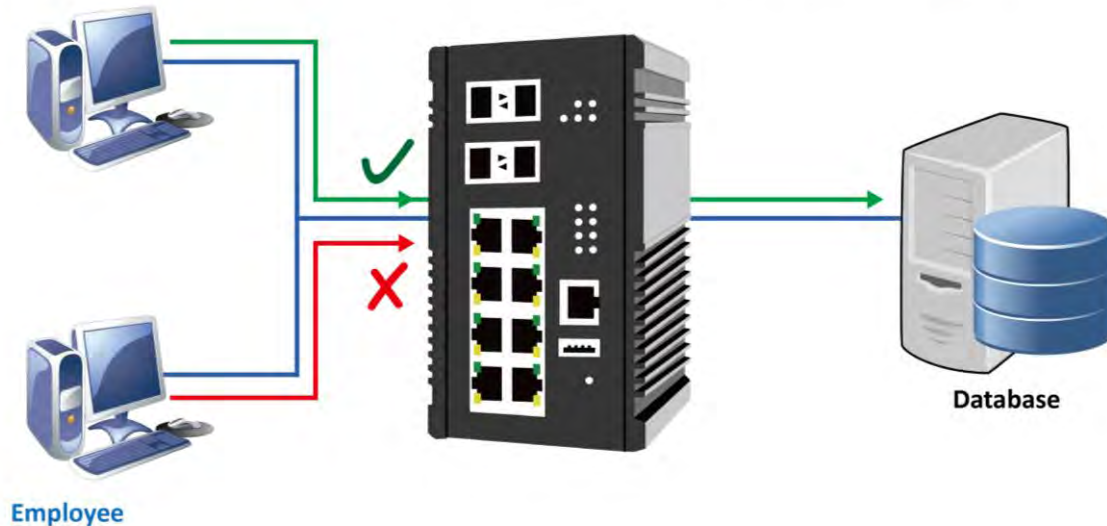

Configure **Permission** by **MAC Address**

1. Login Command Line Interface (CLI) with username and password which are admin/admin by default.
2. Configure ACL rule for the MAC Address of Admin's PC by issuing:

```
acl mac 1 permit src 68:02:35:FF:AB:01 00:00:00:00:00:00
```

Note: the index ID is from 1 to 128

Configure **Permission** by **IP Address**

1. Login Command Line Interface (CLI) with username and password which are admin/admin by default.
2. Configure ACL rule for the IP Address Subnet 192.168.1.0/24 of Admin's PC by issuing:

```
acl ip 1 permit src 192.168.1.99 0.0.0.255
```

Note: the index ID is from 1 to 128

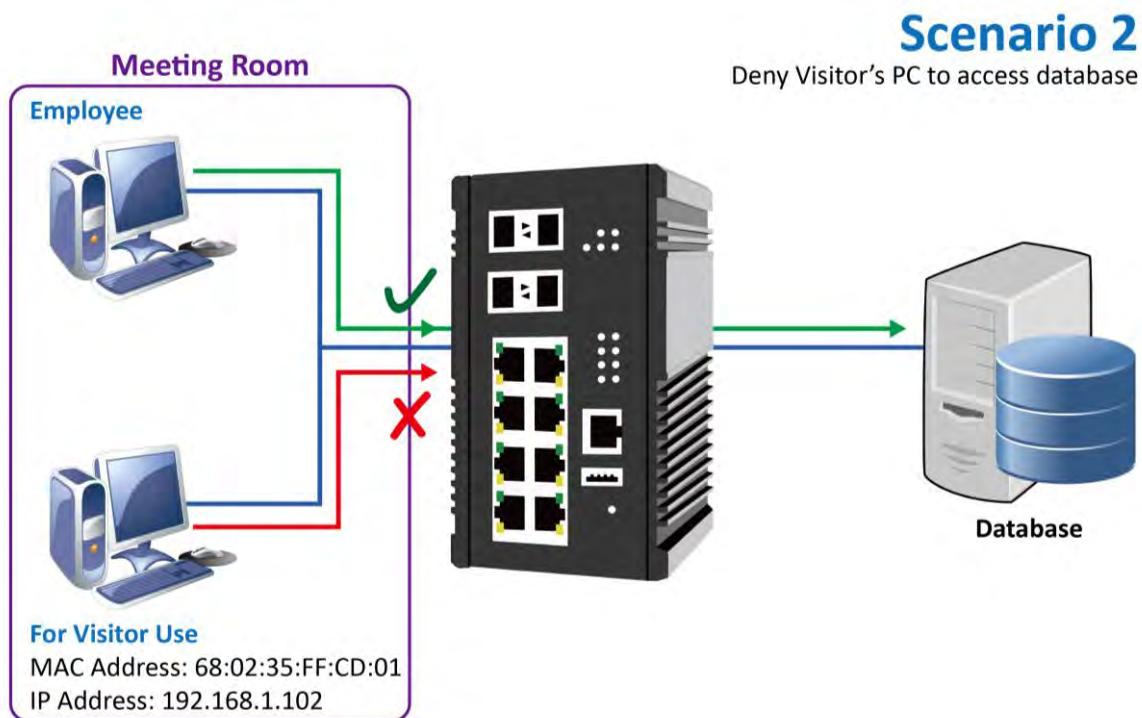

Configure **Deny** by **MAC Address**

3. Login Command Line Interface (CLI) with username and password which are admin/admin by default.
4. Configure ACL rule for the MAC Address of Visitor's PC by issuing:
acl mac 1 drop src 68:02:35:FF:CD:01 ff:ff:ff:ff:ff:ff
Note: the index ID is from 1 to 128

Configure **Deny** by **IP Address**

3. Login Command Line Interface (CLI) with username and password which are admin/admin by default.
4. Configure ACL rule for the IP Address Subnet 192.168.1.0/24 of Visitor's PC by issuing:
acl ip 1 drop src 192.168.1.102 0.0.0.255
Note: the index ID is from 1 to 128

SSH

To reduce the steps for login the system via **SSH** connection, the **public/private key** pair is a good choice for users. The pair of keys is created on the local device and users have to provide the public key to the target device, for example, the Ethernet switch. When users connect to the target device, the system creates a safe connection by SSH. The localhost and target device **authenticates** each other with the public and private keys to make sure the security.

BACKUP HOST KEY FILE

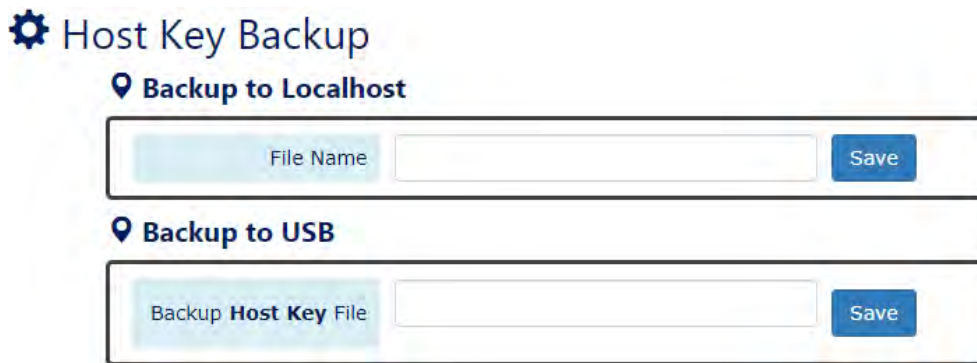

- [Backup to Localhost](#)
 - [File Name](#)
Specify the File Name for the **SSH Host Key** file, which will be saved to the localhost.
- [Backup to USB](#)
Ensure there is a **USB stick** inserted into the USB port.
 - [Backup Host Key File](#)
Specify the File Name for the saved **SSH Host Key** file, which will be saved to the USB.

Note: The file system of USB must be FAT32.

-  (Save Button)

Click the "Save" button to save the configuration file to the **Localhost** or **USB**.

RESTORE HOST KEY FILE

Host Key Restore

Restore from Localhost

Restore from USB

- [Restore from Localhost](#)

- [File Name](#)

- Select the **SSH Host Key** file, which is saved in the Localhost.

- [Restore from USB](#)

- Please ensure there is a **USB stick** inserted into the USB port.

- [File Name in USB](#)

- The File Name of the saved **SSH Host Key** file, which is saved to the USB. If the configuration file is saved in the directory, please specify the **full path**.

Note: The file system of USB must be [FAT32](#).

- (Restore Button)

- Click the "Restore" button to restore the **SSH Host Key** from the **Localhost** or **USB**.

HOST KEY INFORMATION

The current **SSH Host Key** is displayed in the "[SSH Host Key](#)" page. The system only accept one SSH Host Key, once users restore another Host Key, the current Host Key will be replaced.

SSH Host Key

```
AAAAB3NzaC1yc2EAAAADAQABAAQCAQcQlINLLQMBzd+BcavrgDWypnd3
1h5/lwimsRWAnEMFuLwdP3L0PIIK05HLnoprQjyWiJyZmQ9wgucZ1dXUtpne
1yfgxT18CQayACHMj3gTVzWAAPNhS8Ouq7LRMThucySBQouiQHKPlbi2KZm6+IX
DHAmAG1cOM9vnRuiymDkmWBI/xVk4i0Vx+q2rAUcUOKBNm2Ydr/rz4MxoAeQRCJ
UhjeH0yIbhCtM8+stM1/3k54Kn4Ivt9OqDCnLGjC3hwKxLDn1UxPDp46+oKbTIs
8OLAca285mTTKMj8g9XTIGsRD259bsajaj65e7GAI6ovnlWqew4f4jG000OVdh
```

Port Mirroring

Port Mirroring is a feature that copies the incoming or outgoing packets on one or more ports to another destination port. It is very useful to monitor the network traffic and analyze the copied traffic. **Port Mirroring** helps network management to keep a close eye on the network and debug when some issues arise.

CONFIGURE PORT MIRRORING INFORMATION

Port Mirroring

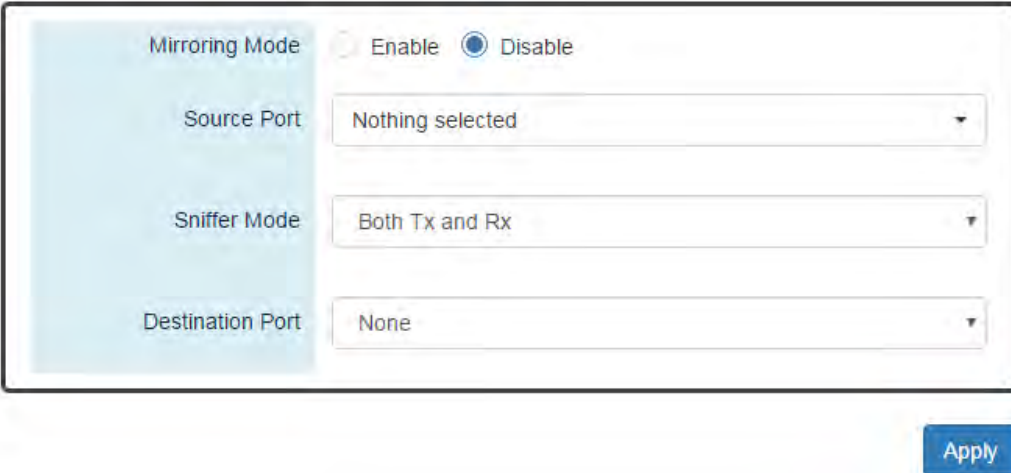

- Mirroring Mode**

“Enable” or “Disable” the Port Mirroring function. If the user enables Port Mirroring function, the system will transmit the traffic of the specific “Sniffer Mode” from “Source Port” to “Destination Port”.
- Source Port**

The traffic on the Source Ports will be sniffed to the Destination Port.
- Sniffer Mode**

Both Tx and Rx: Sniffs both transmitting and receiving traffics.
Tx Only: Sniffs only the transmitting traffic.
Rx Only: Sniffs only the receiving traffic.
- Destination Port**

The traffic will sniff to the Destination Port. This port is usually connected to a host running the software to observe the packets.
-  (Apply Button)

After configuring above fields, click "**Apply**" button to make the changes effective.

Remote SPAN (RSPAN)

Switch port Analyzer (SPAN) provides efficient and high performance traffic monitoring. It duplicated network traffic from a configured interface to another designated interface on the switch. **SPAN** is used for connectivity troubleshooting and for network performance utilization.

An extension of SPAN called **Remote SPAN** or **RSPAN** allows users to monitor traffic from source ports distributed over multiple switches. In other words, users can centralize the network capture devices. **RSPAN** operates by mirroring the traffic from a source port of an RSPAN session on a VLAN. The VLAN is connected to other switches via trunked mode, allowing the traffic on the RSPAN session to be transported across multiple switches. On the switch that contains the destination port for the RSPAN session, the traffic from the VLAN of RSPAN session is simply mirrored out the destination port.

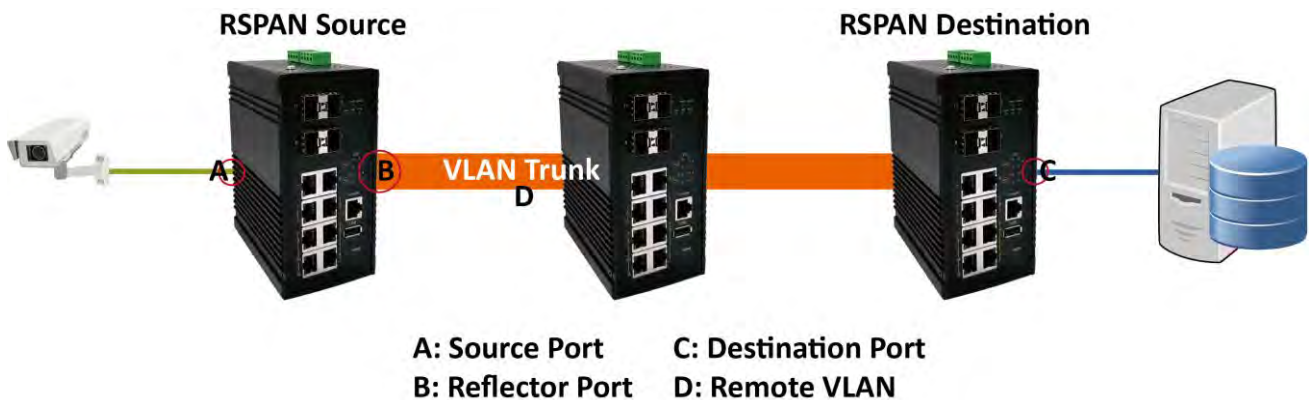

CONFIGURE REMOTE SPAN INFORMATION

The RSPAN is default disabled. The switch provides Source Mode and Destination Mode. Users can select the mode according to their application.

Remote SPAN

Remote SPAN Mode
 Source Enable
 Destination Enable
 Disable

Apply

- Remote SPAN Mode**

“Enable” RSPAN on the Source Mode or Destination Mode or “Disable” RSPAN function.

CONFIGURE REMOTE SPAN SOURCE MODE

Remote SPAN

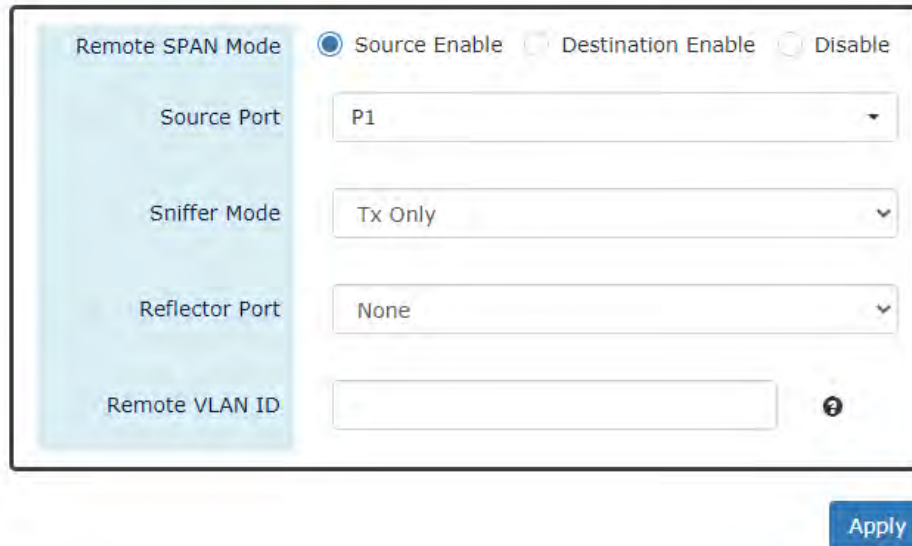

For more information, hover the mouse over the  icon in the system.

- **Source Port**
The traffic through the Source Port will be mirrored to remote devices.
- **Sniffer Mode**
Select the traffic type, **Tx** or **Rx**, to mirror.
- **Reflector Port**
To optimize the utilization of switch interfaces, the Reflector Port on our switches is designed to copy packets from the RSPAN Source Port and forward the copied packets out like an uplink port.
- **Remote VLAN ID**
The configured Remote VLAN ID will be the RSPAN session and used to transmit RSPAN traffic. The Remote VLAN ID configured on the RSPAN Source and Destination has to be the same one.
The range of the Remote VLAN ID is from VLAN **2 to 1001** and VLAN **1006 to 4094**. VLAN 1 and VLAN 1002 to 1005 are reserved VLANs.

CONFIGURE REMOTE SPAN DESTINATION MODE

Remote SPAN

Remote SPAN Mode Source Enable Destination Enable Disable

Destination Port

Remote VLAN ID ?

Apply

*For more information, hover the mouse over the **?** icon in the system.*

- Destination Port**

The copied traffic will be forwarded to this Destination Port.
- Remote VLAN ID**

The configured Remote VLAN ID will be the RSPAN session and used to transmit RSPAN traffic. The Remote VLAN ID configured on the RSPAN Source and Destination has to be the same one.

The range of the Remote VLAN ID is from VLAN **2 to 1001** and VLAN **1006 to 4094**. VLAN 1 and VLAN 1002 to 1005 are reserved VLANs.

CONFIGURATION EXAMPLE FOR RSPAN

In the following diagram, the **SWA** is the **RSPAN Source**, and the **SWC** is the **RSPAN Destination**. Between SWA and SWC, there is a SWB which is a normal switch. We are going to monitor the traffic from the IP Camera on the left side to the Server on the right side.



Step-by-step Configuration

- Login Web Console and click menu *“Diagnostics”* -> *“Remote SPAN”*
- Configure for **SWA**
 - Click **“Source Enable”** and there will show other related configuration items.
 - Select the Source Port (**Port 3**) that will be monitored.

- iii. Select the **Sniffer Mode**, normally called traffic type. For this example, we want to monitor the traffic from the IP Camera, so we have to select “Rx”.
- iv. Select the **Reflector Port** which will forward the copied traffic to the destination. On the SWA, **Port 9** is the Uplink and Reflector Port.
- v. Decide the **Remote VLAN ID** for **RSPAN Session**; the copied traffic will be transmitted through this VLAN trunk. We use **VLAN 3000** on this example.
- vi. Click “**Apply**” button to effect RSPAN configurations.

Remote SPAN

Remote SPAN Mode Source Enable Destination Enable Disable

Source Port

Sniffer Mode

Reflector Port

Remote VLAN ID 

[Apply](#)



- vii. Configure uplink port (**Port 9**) to **tagged** member on **VLAN 3000**.
- viii. Click “**Apply**” button on the bottom of the page to make the VLAN effective.

VLAN Settings

Management VLAN

VLAN ID 

VLAN Member Settings

VLAN ID 	Name 	Untagged Ports	Tagged Ports	
<input type="text" value="1"/>	<input type="text" value="-"/>	12 items selected ▾	Nothing selected ▾	✕
<input type="text" value="3000"/>	<input type="text" value="RSPAN"/>	Nothing selected ▾	P9 ▾	✕

7. Configure for **SWB**

- i. Configure the ports (**Port 9** and **Port 10**) connected with SWA and SWC to tagged members on **VLAN 3000**.
- ii. Click “**Apply**” button on the bottom of the page to make the VLAN effective.

VLAN Settings

Management VLAN

VLAN ID

?

VLAN Member Settings

VLAN ID ?	Name ?	Untagged Ports	Tagged Ports	+
<input style="width: 50px;" type="text" value="1"/>	<input style="width: 50px;" type="text" value="-"/>	12 items selected ▾	Nothing selected ▾	✕
<input style="width: 50px;" type="text" value="3000"/>	<input style="width: 50px;" type="text" value="RSPAN"/>	Nothing selected ▾	P9, P10 ▾	✕

8. Configure for SWC

- i. Click **“Destination Enable”** and there will show other related configuration items.
- ii. Select the Destination Port (**Port 5**) that the copied traffic will be transmitted to.
- iii. Configure the **Remote VLAN ID** to **VLAN 3000** for **RSPAN Session**.
- iv. Click **“Apply”** button to effect RSPAN configurations.

Remote SPAN

Remote SPAN Mode

Source Enable
 Destination Enable
 Disable

Destination Port

P5 ▾

Remote VLAN ID

3000

?

Apply

- v. Configure uplink port (**Port 10**) to **tagged** member on **VLAN 3000**.
- vi. Click **“Apply”** button on the bottom of the page to make the VLAN effective.

VLAN Settings

Management VLAN

VLAN ID

?

VLAN Member Settings

VLAN ID ?	Name ?	Untagged Ports	Tagged Ports	+
<input style="width: 50px;" type="text" value="1"/>	<input style="width: 50px;" type="text" value="-"/>	12 items selected ▾	Nothing selected ▾	✕
<input style="width: 50px;" type="text" value="3000"/>	<input style="width: 50px;" type="text" value="RSPAN"/>	Nothing selected ▾	P10 ▾	✕

Ping

Ping is a tool used to test the reachability of a device on the IP network. Ping is enabled by sending **Internet Control Message Protocol (ICMP)** request to the target device and waits for the response packet from the target device to check the connection.

PING ANOTHER DEVICE WITH IPv4/IPv6

Ping

Start
Stop
Clear
Reset

Type	<input checked="" type="radio"/> IPv4 <input type="radio"/> IPv6
IP Address	<input style="width: 90%;" type="text" value="192.168.10.88"/> ✓
Count	<input style="width: 90%;" type="text" value="3"/> ✓ ⓘ
Result	<pre>----- Start Ping 192.168.10.88 ----- 64 bytes from 192.168.10.88: ttl=128 time=6.751 ms (1) 64 bytes from 192.168.10.88: ttl=128 time=11.794 ms (2) 64 bytes from 192.168.10.88: ttl=128 time=10.892 ms (3) ----- Ping Statistics ----- Transmitted: 3 packets, Received: 3 packets, Loss: 0.00% ----- End (Count=3) -----</pre>

For more information, hover the mouse over the ⓘ icon in the system.

- **Type**
Ping a connected device with “IPv4” or “IPv6” protocol.
- **IP Address**
The IP address of the connected device is verified based on the type.
- **Count**
Sets the count times. The system will send “Count” number ICMP packets to the specific IP address and wait for the response.
The range of the Count is **from 3 to 50**.
The default Count is **3**.
- **Result**
The result of the ping shows the response from the specific IP address. If the specific IP address does not respond, it displays No Response.

- **“Start” Button**
Click the “Start” Button to start the ping to the IP address.
- **“Stop” Button**
Click the “Stop” Button to stop the ping to the IP address before the count is completed.
- **“Clear” Button**
Click the “Clear” Button to clear the “Result”.
- **“Reset” Button**
Click the “Reset” Button to clear the “Result” and reset the “IP Address” and “Count” number.

Traceroute

Traceroute is another tool used to test the reachability of a device on the IP network. Traceroute is enabled by sending **Internet Control Message Protocol (ICMP)** request to the target device with the limited TTL. TTL value start from 1 and count on. System can get the response of the device on the path.

TRACEROUTE DEVICE WITH IPv4/IPv6

Traceroute

Start
Stop
Clear
Reset

Type	<input checked="" type="radio"/> IPv4 <input type="radio"/> IPv6
IP Address	<input style="width: 90%;" type="text" value="8.8.8.8"/> ✓
Hops	<input style="width: 90%;" type="text" value="20"/> ✓ ?
Result	<pre> ----- Start Traceroute 8.8.8.8 ----- 1 192.168.1.1 (192.168.1.1) 26.227 ms 1 192.168.1.1 (192.168.1.1) 5.592 ms 2 * 1 192.168.1.1 (192.168.1.1) 9.803 ms 1 192.168.1.1 (192.168.1.1) 1.888 ms 5 * 1 192.168.1.1 (192.168.1.1) 26.513 ms 1 192.168.1.1 (192.168.1.1) 8.664 ms 8 * 4 220.128.4.122 (220.128.4.122) 4.834 ms 7 72.14.218.140 (72.14.218.140) 9.248 ms 10 8.8.8.8 (8.8.8.8) 14.662 ms ----- End (Current Hops=12) ----- </pre>

For more information, hover the mouse over the  icon in the system.

- **Type**
Trace a connected device with “**IPv4**” or “**IPv6**” protocol.
- **IP Address**
The IP address of the connected device is verified based on the type.
- **Hops**
Sets the TTL count times. The system will send maximum “Count” number ICMP packets to the specific IP address and wait for the response.
The range of the Hops count is **from 1 to 255**.
The default Hops count is **3**.

- [Result](#)
The result of the traceroute shows the response from each IP address. If the specific IP address does not respond, it displays No Response.
- [“Start” Button](#)
Click the “Start” Button to start the traceroute to the IP address.
- [“Stop” Button](#)
Click the “Stop” Button to stop the traceroute to the IP address before the count is completed.
- [“Clear” Button](#)
Click the “Clear” Button to clear the “Result”.
- [“Reset” Button](#)
Click the “Reset” Button to clear the “Result” and reset the “IP Address” and “Count” number.

Cable Diagnostic

This command can check the status of copper cables with the time domain reflectometer (TDR) technology. It can detect a cable fault by sending a detect signal and read the reflecting back. With this test, it can help to identify and narrow down the physical level issue.

DISPLAY CABLE DIAGNOSTIC

```
Switch(config-lan3)# show cable-diagnostic
cable (4 pairs, length +/- 10 meters)
    pair A Ok, length 5 meters
    pair B Ok, length 5 meters
    pair C Ok, length 5 meters
    pair D Ok, length 5 meters
```

- **Port Selector**

Select the port number to test.

Port 1 to N, where N is based on the total port number.

- **Cable status**

The status of cable. It contains the number of pairs in the cable and the error amount.

Usually there are 4 pair in the CAT-5E cable for Gigabit Ethernet link.

- **Pair status**

The status of each pair of port. 'Ok' status means cable is connected to another node.

'Open' status means cable does not connect to any device.

- **Length**

The length of each pair of port in meters. Please note the error amount is around 10 meters due to the TDR technology. The short cable less than the error amount might be untastable.

LLDP

LLDP is **Link Layer Discovery Protocol** and it is a vendor-neutral layer 2 protocol that is defined by **IEEE 802.1AB**. **LLDP** is used in advertising identity of the devices, capabilities and neighbors on the LAN. The information from the neighbors enables the switch to quickly identify the devices and interoperate with each other more smoothly and efficiently. The neighbor table shows the information about the device that is next to the port. The LLDP can only get information from the device that is close to it. If the users want to know the topology of the LAN, they can collect all information from the device and analysis the neighbor table.

CONFIGURE LLDP INFORMATION

LLDP Settings



For more information, hover the mouse over the  icon in the system.

- [LLDP Mode](#)
“Enable” or “Disable” the LLDP function.
- [LLDP Timer](#)
The LLDP Timer is a time interval to send LLDP messages.
The range of the LLDP Timer is **from 5 to 32767** seconds.
The default LLDP Timer is **30** seconds.
-  (Apply Button)
After configuring above fields, click "**Apply**" button to make the changes effective.

LLDP NEIGHBOR TABLE

LLDP Neighbor

Show entries Search:

Local Port	Remote System Name	Chassis ID	Remote Port	Port ID	Address
3	MT-0804G	00:AA:BB:CC:11:02	lan8	local 8	192.168.10.11
6	L2GigaBitEthern...	00:03:CE:11:22:33	Sid #2, Po...	local 1017	192.168.10.90

Showing 1 to 2 of 2 entries

Auto Refresh

Refresh Rate: seconds 

- [Local Port](#)
The port connected to the LLDP neighbor on the local switch.
- [Remote System Name](#)
This is the system name of the LLDP neighbor. This value is set and provided by the remote device.
- [Chassis ID](#)
The Chassis ID defines the **MAC Address** of the LLDP neighbor.
- [Remote Port](#)
This field displays the **port information** received from the LLDP neighbor.
- [Port ID](#)
The Port ID displays the **port identity** of the connected port on the LLDP neighbor.
- [Address](#)
The Address displays the **IP address** of the LLDP neighbor.

System Warning

System Warning contains “System Event Log”, “SMTP Settings”, and “Event Selection” for different types of services such as “Fault Alarm”, “System Log”, “SMTP”, and “SNMP Trap”. These logs are very useful for the administrator to manage and debug the system. When the system is powered off or when someone tries to login the system or the system reboots abnormally, or when some of the interfaces are linked down, the system sends log messages to notify specific users and record the events on the server or assigned platform. Users can also connect an alarm buzzer to the relay alarm pins. When the configured “Fault Alarm” events are triggered, the alarm buzzer will ring to notify the users.

CONFIGURE SYSTEM WARNING INFORMATION

System Log Settings

System Log Mode

Local
 Remote
 USB

Remote Server IP Address

?

Service Port

514

?

Apply

For more information, hover the mouse over the  icon in the system.

- [System Log Mode](#)
- Select the checkbox to send system log to Local (Switch), Remote, or USB when events happened.
- [Remote Server IP Address](#)
The field contains the IP Address of the remote server. If the “**Remote**” mode is enabled, users have to assign this IP Address to receive the system logs. The system supports both **IPv4** and **IPv6** addresses for the remote server.
- [Service Port](#)
The port is used to listen to the system log packets on the remote server.
The range of the Service Port is **from 1 to 65535**.
The default Service Port is **514**.
-  (Apply Button)

After configuring above fields, click "**Apply**" button to make the changes effective.

SYSTEM EVENT LOG

System Event Log

```
Jan 1 00:06:35 notice.user emonitor [EVENT] Port 2: LINK-UP
Jan 1 00:06:35 notice.user emonitor [EVENT] Port 5: LINK-UP
Jan 1 00:06:38 notice.user emonitor [EVENT] Port 2: LINK-DOWN
Jan 1 00:06:39 notice.user emonitor [EVENT] Port 5: LINK-DOWN
Jan 1 00:06:47 notice.user emonitor [EVENT] Port 3: LINK-UP
Jan 1 00:06:47 notice.user emonitor [EVENT] Port 8: LINK-UP
```

- **Log Text Area**
The system event information displays if the “**Local**” system log mode is enabled and the configured events are triggered.
- (Clear Button)
Click the “Clear” button to clear the system event log in the text area.
- (Refresh Button)
Click the “Refresh” button to refresh the system event log in the text area.

CONFIGURE SMTP INFORMATION

SMTP Settings

Server Settings

SMTP Status	<input type="radio"/> Enable <input checked="" type="radio"/> Disable
Server Address	<input type="text"/>
Server Port	<input type="text" value="25"/> ?
Sender E-mail	<input type="text"/>
Mail Subject	<input type="text" value="Switch Notification"/> ?
SMTP Authentication	<input checked="" type="radio"/> Enable <input type="radio"/> Disable
User Name	<input type="text"/> ?
Password	<input type="password"/> ?

Recipient Settings

E-mail Address 1	<input type="text"/>
E-mail Address 2	<input type="text"/>
E-mail Address 3	<input type="text"/>
E-mail Address 4	<input type="text"/>

Apply

For more information, hover the mouse over the ? icon in the system.

- Server Settings
 - SMTP Status
“Enable” or “Disable” the SMTP function.
 - Server Address
This is the **IP address** or **URL** of the SMTP Server. For example, the SMTP server address provided by Google is “smtp.gmail.com”.
 - Server Port
This field is the port listening on the server for the SMTP request. For security, we suggest users configure the server port to **465** for **SSL** or **587** for **TLS**.
The range of the Service Port is **from 1 to 65535**.
The default Service Port is **25**. Port 25 is the default port for e-mail server.
 - Sender E-mail
The Sender E-mail is the e-mail address used to send the notifications to Recipients.
 - Mail Subject

The Mail Subject is a string that is displayed in the E-mail title.

Note: #, \, ', ", ? are **invalid** characters.

- SMTP Authentication

“Enable” or “Disable” to authenticate the SMTP server with the configured username and password.

- User Name

The username is used in authentication with the SMTP server.

The **max. length** for the User Name is **32 characters**.

Note: #, \, ', ", ? are **invalid** characters.

- Password

The password is used in authentication with the SMTP server.

The **max. length** for the Password is **32 characters**.

Note: #, \, ', ", ? are **invalid** characters.

- Recipient Settings

- E-mail Address 1-4

The configured e-mail address will receive the notifications if the SMTP is enabled and the events set on “Event Selection” are triggered.

-  (Apply Button)

After configuring above fields, click "**Apply**" button to make the changes effective.

CONFIGURE SYSTEM EVENT SELECTIONS

System Event Selections

Event	Fault Alarm	System Log	SMTP	SNMP
Authentication Failure	-	Disable ▾	Disable ▾	Disable ▾
ERPS Change	-	Disable ▾	Disable ▾	Disable ▾
Power 1	Disable ▾	Disable ▾	Disable ▾	Disable ▾
Power 2	Disable ▾	Disable ▾	Disable ▾	Disable ▾
Power 3	Disable ▾	Disable ▾	Disable ▾	Disable ▾
Power 4	Disable ▾	Disable ▾	Disable ▾	Disable ▾
Cold Start	-	Disable ▾	Disable ▾	Disable ▾
Warm Start	-	Disable ▾	Disable ▾	Disable ▾
Digital Input	Disable ▾	Disable ▾	Disable ▾	Disable ▾

 Apply

- **Event**

There are 5 events on the System Events.

Authentication Failure: Login failed on the web console or CLI. It may be caused due to incorrect username or password.

ERPS Change: The ERPS function is working and the topology is changed.

Power 1 - 4: The power 1 to 4 is powered off.

Cold Start: The system reboots due to interruption of power supply.

Warm Start: The system reboots by issuing “reboot” command on CLI or clicking the “reboot icon” on the web console.

Digital Input: The signal from the digital input is changed from high to low or low to high.

-  (Apply Button)

After configuring above fields, click "**Apply**" button to make the changes effective.

CONFIGURE INTERFACE EVENT SELECTIONS

Interface Event Selections

Event	Fault Alarm	System Log	SMTP	SNMP
All Ports Link	<input type="checkbox"/> Down	<input type="checkbox"/> Up <input type="checkbox"/> Down	<input type="checkbox"/> Up <input type="checkbox"/> Down	<input type="checkbox"/> Up <input type="checkbox"/> Down
Port 1 Link	<input type="checkbox"/> Down	<input type="checkbox"/> Up <input type="checkbox"/> Down	<input type="checkbox"/> Up <input type="checkbox"/> Down	<input type="checkbox"/> Up <input type="checkbox"/> Down
Port 2 Link	<input type="checkbox"/> Down	<input type="checkbox"/> Up <input type="checkbox"/> Down	<input type="checkbox"/> Up <input type="checkbox"/> Down	<input type="checkbox"/> Up <input type="checkbox"/> Down
Port 3 Link	<input type="checkbox"/> Down	<input type="checkbox"/> Up <input type="checkbox"/> Down	<input type="checkbox"/> Up <input type="checkbox"/> Down	<input type="checkbox"/> Up <input type="checkbox"/> Down
Port 4 Link	<input type="checkbox"/> Down	<input type="checkbox"/> Up <input type="checkbox"/> Down	<input type="checkbox"/> Up <input type="checkbox"/> Down	<input type="checkbox"/> Up <input type="checkbox"/> Down
Port 5 Link	<input type="checkbox"/> Down	<input type="checkbox"/> Up <input type="checkbox"/> Down	<input type="checkbox"/> Up <input type="checkbox"/> Down	<input type="checkbox"/> Up <input type="checkbox"/> Down
Port 6 Link	<input type="checkbox"/> Down	<input type="checkbox"/> Up <input type="checkbox"/> Down	<input type="checkbox"/> Up <input type="checkbox"/> Down	<input type="checkbox"/> Up <input type="checkbox"/> Down
Port 7 Link	<input type="checkbox"/> Down	<input type="checkbox"/> Up <input type="checkbox"/> Down	<input type="checkbox"/> Up <input type="checkbox"/> Down	<input type="checkbox"/> Up <input type="checkbox"/> Down
Port 8 Link	<input type="checkbox"/> Down	<input type="checkbox"/> Up <input type="checkbox"/> Down	<input type="checkbox"/> Up <input type="checkbox"/> Down	<input type="checkbox"/> Up <input type="checkbox"/> Down
Port 9 Link	<input type="checkbox"/> Down	<input type="checkbox"/> Up <input type="checkbox"/> Down	<input type="checkbox"/> Up <input type="checkbox"/> Down	<input type="checkbox"/> Up <input type="checkbox"/> Down
Port 10 Link	<input type="checkbox"/> Down	<input type="checkbox"/> Up <input type="checkbox"/> Down	<input type="checkbox"/> Up <input type="checkbox"/> Down	<input type="checkbox"/> Up <input type="checkbox"/> Down
Port 11 Link	<input type="checkbox"/> Down	<input type="checkbox"/> Up <input type="checkbox"/> Down	<input type="checkbox"/> Up <input type="checkbox"/> Down	<input type="checkbox"/> Up <input type="checkbox"/> Down
Port 12 Link	<input type="checkbox"/> Down	<input type="checkbox"/> Up <input type="checkbox"/> Down	<input type="checkbox"/> Up <input type="checkbox"/> Down	<input type="checkbox"/> Up <input type="checkbox"/> Down



- **Event**

The events on the “Interface Events” display the **link status** for each port. Fault Alarm is triggered only during link down and other system log types support both link up and link down.

- **Fault Alarm**

The **Fault LED** will turn on **red** and relay will turn ON, if the configured events are triggered. By default, the Fault LED is **green** and relay is turned OFF in the normal situation,.

- [System Log](#)

When the configured events are triggered, the logs will be displayed in the “System Event Log” page, remote server, or saved to a USB file named “**message**”. This is based on the settings of the “**System Log Mode**” in the “**System Log Settings**” page.

Note: The file system of USB must be FAT32.

- [SMTP](#)

If the SMTP is enabled and the configured events are triggered, the system will send an e-mail notification to the e-mail addresses of the assigned recipient set in the “**SNMP Settings**” page.

- [SNMP](#)

If the SNMP Trap is enabled and the configured events are triggered, the system will send event information to the assigned “**Trap Receiver IP**”, which is set in the “**SNMP Trap**” page.

-  (Apply Button)

After configuring above fields, click "**Apply**" button to make the changes effective.

CONFIGURE SFP DDM EVENT SELECTIONS

SFP DDM Event Selections

Port 9
▼

Event	Fault Alarm	System Log	SMTP	SNMP
Current	Disable ▼	Disable ▼	Disable ▼	Disable ▼
Rx Power	Disable ▼	Disable ▼	Disable ▼	Disable ▼
Tx Power	Disable ▼	Disable ▼	Disable ▼	Disable ▼
Temperature	Disable ▼	Disable ▼	Disable ▼	Disable ▼
Voltage	Disable ▼	Disable ▼	Disable ▼	Disable ▼



- [Event](#)

There are 5 events on the “SFP DDM Events”: **Current**, **Rx Power**, **Tx Power**, **Temperature**, and **Voltage**. Enable or Disable the event fault alarm or system warning when the value is higher than the high alarm/warning threshold or the value is lower than the low alarm/warning threshold.

Data Collection

The health of switch system is very important in the real application. For most switches, they provide basic real-time traffic and PoE status but users need the long time records to analyze and statistic for the system. For this purpose, we implement the Data Collection function to collect traffic and PoE status periodically and save the collected data to the USB device. In addition to this, we also provide charts to display the collected data. Users can easily recognize the situation of the switch system and find the unusual points from the charts.

To ensure the accuracy of the data, the NTP service must be turned on before enable Data Collect function, so that when users find an abnormal record, they can trace it by the recording time. And there is no worry for the size of system storage because the data is saved in the USB. The data even can be move to other devices to display or users can use the collected raw data to do other application.

CONFIGURE DATA COLLECTION SETTINGS

USB and **NTP** are essential before users enable the Data Collection functions. Please check if there is an USB inserted and the NTP service is also enabled. The file system of USB must be FAT32.

 **Collection Settings**

Detect USB ... **Fail**
Check NTP Service ... **Disabled**

Please insert USB device and **config NTP service** to enable data collection function.

Please enable Collection function before enabling Traffic and PoE Data Collection.
The system will collect data only when the Collection function is enabled.

Collection	<input type="radio"/> Enable	<input checked="" type="radio"/> Disable
PoE Data Collection	<input type="radio"/> Enable	<input checked="" type="radio"/> Disable
Traffic Data Collection	<input type="radio"/> Enable	<input checked="" type="radio"/> Disable

- **Collection**
“Enable” or “Disable” Data Collection Function on the switch. The Traffic and PoE Data Collection can be enabled only when the Collection is enabled.
- **PoE Data Collection (PoE Models Only)**
“Enable” or “Disable” PoE Data Collection function on the switch.
- **Traffic Data Collection**
“Enable” or “Disable” Traffic Data Collection function on the switch.

RESET COLLECTED DATA

Collected Data Reset

Port	Traffic		PoE	
	Sel. All	Desel. All	Sel. All	Desel. All
1	<input type="checkbox"/>	<input type="checkbox"/>	<input type="checkbox"/>	<input type="checkbox"/>
2	<input type="checkbox"/>	<input type="checkbox"/>	<input type="checkbox"/>	<input type="checkbox"/>
3	<input type="checkbox"/>	<input type="checkbox"/>	<input type="checkbox"/>	<input type="checkbox"/>
4	<input type="checkbox"/>	<input type="checkbox"/>	<input type="checkbox"/>	<input type="checkbox"/>
5	<input type="checkbox"/>	<input type="checkbox"/>	<input type="checkbox"/>	<input type="checkbox"/>
6	<input type="checkbox"/>	<input type="checkbox"/>	<input type="checkbox"/>	<input type="checkbox"/>
7	<input type="checkbox"/>	<input type="checkbox"/>	<input type="checkbox"/>	<input type="checkbox"/>
8	<input type="checkbox"/>	<input type="checkbox"/>	<input type="checkbox"/>	<input type="checkbox"/>
9	<input type="checkbox"/>	<input type="checkbox"/>	<input type="checkbox"/>	<input type="checkbox"/>
10	<input type="checkbox"/>	<input type="checkbox"/>	<input type="checkbox"/>	<input type="checkbox"/>
11	<input type="checkbox"/>	<input type="checkbox"/>	<input type="checkbox"/>	<input type="checkbox"/>
12	<input type="checkbox"/>	<input type="checkbox"/>	<input type="checkbox"/>	<input type="checkbox"/>

[Back](#) [Next](#) [Reset](#)

- **Port**
Port 1 to Port N, N is based on the total port number.
- **Traffic**
Check the checkbox to reset the data for the designated port. After reset, the collected data will be removed from the USB.
Note: It cannot undo after reset, please make sure you want to reset the file.
- **PoE (PoE Models Only)**
Port 1 to Port N, N is based on the total port number.

POE STATUS CHARTS

⚙️ PoE Status Charts

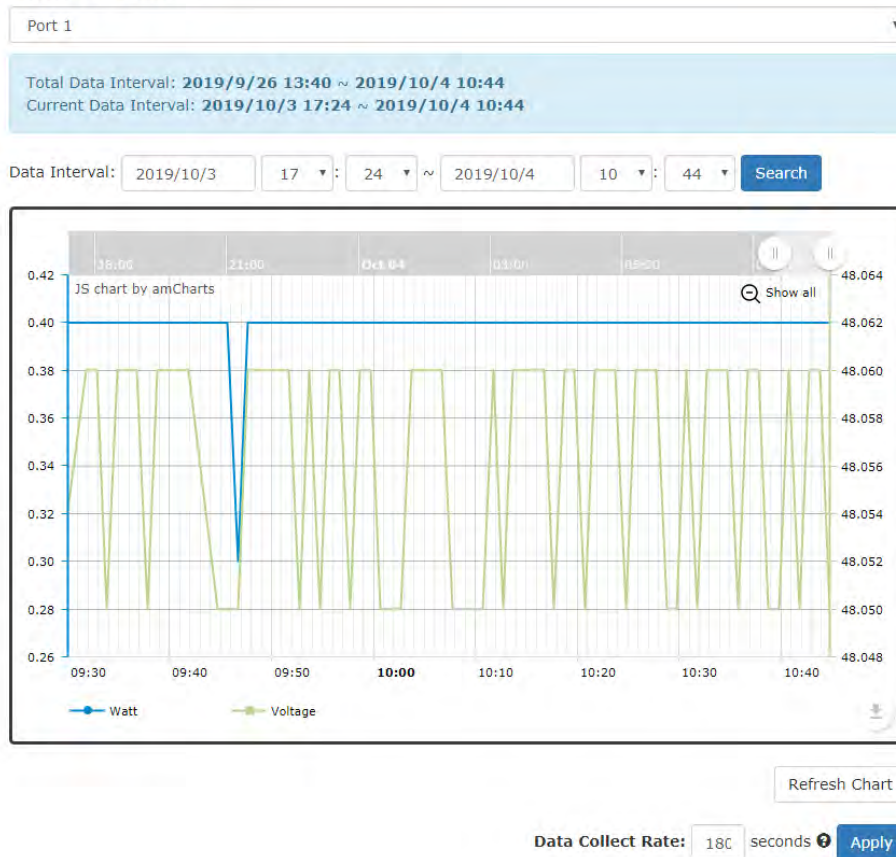

For more information, hover the mouse over the  icon in the system.

- **Port (Drop-down Selector)**
Port1 to PortN, where N is based on the total PoE port number. The PoE Status Chart is displayed by port.
- **Total Data Interval**
The interval is the date time from first data to last data that collected in the USB.
- **Current Data Interval**
The interval is the date time from first data to last data that displayed on the current chart.
- **Data Interval (Drop-down Selector)**
Select an interval to search data. The returned data will be displayed on the chart. The number of data is limited by the system, if the selected interval is larger than the limitation, the system will return an acceptable interval (Shown as the following screenshot).

Max Search Interval from 2019/09/26 17:52 is to 2019/09/30 05:21

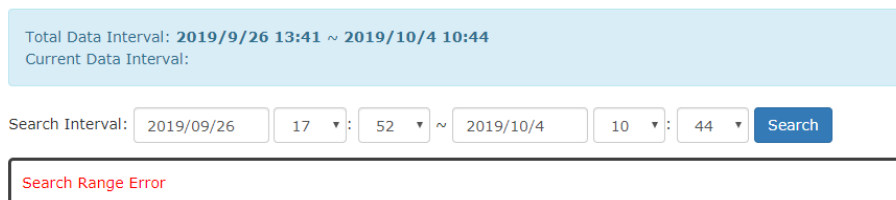

Note: After configuring “Data Interval”, click "Search" button to get data in the interval.

- [Chart](#)

The chart displays both watts (blue line) and voltage (green line) data.

- [Refresh Chart \(Button\)](#)

Press the Refresh Chart button to refresh the chart and get the updated data.

- [Data Collect Rate](#)

The field is the period to collect data. The system will get the real-time data periodically according to the configured Data Collect Rate.

Note: PoE Status Charts and Interface Traffic Charts are shared the same Data Collect Rate.

The range of the Data Collect Rate is **from 60 to 600** seconds.

The default Data Collect Rate is **180** seconds.

Note: After configuring “Data Collect Rate”, click "Apply" button to make the changes effective.

INTERFACE TRAFFIC CHARTS

⚙ Interface Traffic Charts

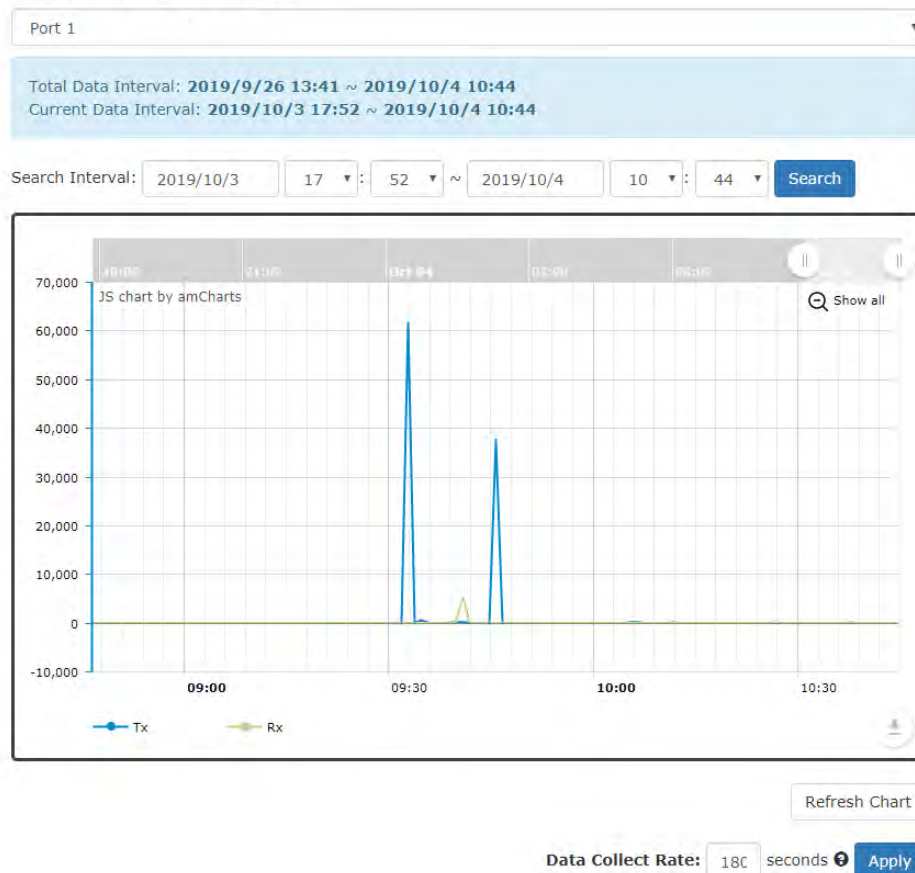

For more information, hover the mouse over the ? icon in the system.

- [Port \(Drop-down Selector\)](#)
Port1 to PortN, where N is based on the total switch port number. The Interface Traffic Chart is displayed by port.
- [Total Data Interval](#)
The interval is the date time from first data to last data that collected in the USB.
- [Current Data Interval](#)
The interval is the date time from first data to last data that displayed on the current chart.
- [Data Interval \(Drop-down Selector\)](#)
Select an interval to search data. The returned data will be displayed on the chart. The number of data is limited by the system, if the selected interval is larger than the limitation, the system will return an acceptable interval (Shown as the following screenshot).

Max Search Interval from 2019/09/26 17:52 is to 2019/9/30 05:21

The screenshot shows a web interface for configuring data intervals. At the top, it displays 'Total Data Interval: 2019/9/26 13:41 ~ 2019/10/4 10:44' and 'Current Data Interval:'. Below this is a search interval configuration area with input fields for start and end dates and times, and a 'Search' button. The search interval is set to '2019/09/26 17:52' to '2019/10/4 10:44'. A red error message 'Search Range Error' is displayed below the search interval fields, indicating that the selected range exceeds the system's maximum search interval.

Note: After configuring “Data Interval”, click "**Search**" button to get data in the interval.

- [Chart](#)
The chart displays transmitted bytes (blue line) and received bytes (green line) data.
- [Refresh Chart \(Button\)](#)
Press the Refresh Chart button to refresh the chart and get the updated data.
- [Data Collect Rate](#)
The field is the period to collect data. The system will get the real-time data periodically according to the configured Data Collect Rate.
Note: Interface Traffic Charts and PoE Status Charts are shared the same Data Collect Rate. The range of the [Data Collect Rate](#) is **from 60 to 600** seconds. The default [Data Collect Rate](#) is **180** seconds.
Note: After configuring “Data Collect Rate”, click "**Apply**" button to make the changes effective.

MAC Table

MAC address is **Media Access Control** address, which is used in layer 2 switching. A **MAC Address table** is maintained by the switch to transmit frames more efficiently. When the switch receives a frame, the system will check the MAC table and forward the frame to the corresponding port. The MAC Address table is built dynamically by the received frames and when the system receives a frame with an unknown MAC address, it **floods** the frame to all LAN ports in the same VLAN. When the destination device replies the system identifies the MAC Address and the target port.

The MAC Address for the switch is designed as per-port-per-MAC, which implies each port has its own MAC Address. This is for MAC sensitive protocols such as Spanning-tree protocol. The MAC Address display on the right side of WEB GUI is the MAC Address for whole system and the MAC Addresses for the ports are increasing by 1 from port 1 to last port.

For example, the MAC Address of the system is 68:02:35:FF:FF:05, and there are 8-port on the switch. The MAC Address for each port will be:

Port	MAC Address	Port	MAC Address
Port 1	68:02:35:FF:FF:06	Port 5	68:02:35:FF:FF:0A
Port 2	68:02:35:FF:FF:07	Port 6	68:02:35:FF:FF:0B
Port 3	68:02:35:FF:FF:08	Port 7	68:02:35:FF:FF:0C
Port 4	68:02:35:FF:FF:09	Port 8	68:02:35:FF:FF:0D

Note: The MAC Address is hex format, so the number after “09” is “0A”.

CONFIGURE STATIC MAC ADDRESS INFORMATION

Static MAC Address Settings



Apply

For more information, hover the mouse over the  icon in the system.

- [VID](#)
The VID is the VLAN group ID, which contains the configured MAC Address .
The range of the VID is **from 1 to 4094**.
- [MAC Address](#)
This field is the static MAC Address of the configured member ports in the VLAN group.
- [Group Member](#)

The Group Member is the port(s) in the VLAN group, to which the configured MAC Address belongs.

- **+**: Click the **plus icon** to add a static MAC Address row.
- **X**: Click the **remove icon** to delete the static MAC Address row.
- **Apply** (Apply Button)

After configuring above fields, click "**Apply**" button to make the changes effective.

MAC ADDRESS TABLE

MAC Address Table

Show entries Search:

VID	MAC Address	Type	Source
VLAN 1	EC:08:6B:06:96:53	Learning	2
VLAN 1	1C:49:7B:6A:F3:41	Learning	5
VLAN 1	1C:1B:0D:66:75:EB	Learning	5
VLAN 1	01:00:5E:7F:FF:FA	Static	2
VLAN 1	40:8D:5C:EA:92:02	Learning	5
VLAN 1	9C:EB:E8:3A:54:E7	Learning	5
VLAN 1	40:8D:5C:EA:8D:C3	Learning	5
VLAN 1	1C:1B:0D:66:F7:F8	Learning	5
VLAN 1	FC:3F:DB:53:19:8E	Learning	5
VLAN 1	A4:02:B9:80:7D:66	Learning	5

Showing 1 to 10 of 10 entries First Previous Next Last

Auto Refresh **Refresh**

Refresh Rate: seconds 

- **VID**
The VID is the VLAN group ID, which contains the configured MAC Address.
- **MAC Address**
The MAC Address column displays the learnt or configured MAC Addresses.
- **Type**
The Type column displays the type (Learning or Static) of the MAC Address.
Learning: The MAC address is learnt from the transmitting frames.
Static: The MAC Address is configured by the users or the system.
- **Source**
The Source column displays the port(s) to which the MAC Address belong.

Authorization

The "Username" and "Password" are very important information both in the "Command Line Interface" or "Web Console". Users have to login into the system before doing any configuration. We strongly suggest the users to change at least the password **for security** when they are going to use this device.

We also provide authentication with **RADIUS/TACACS+** server from software **version 1.0.3**. Users can maintain the login information in their own RADIUS/TACACS+ database and allow several usernames/passwords to login the system.

CONFIGURE LOGIN INFORMATION

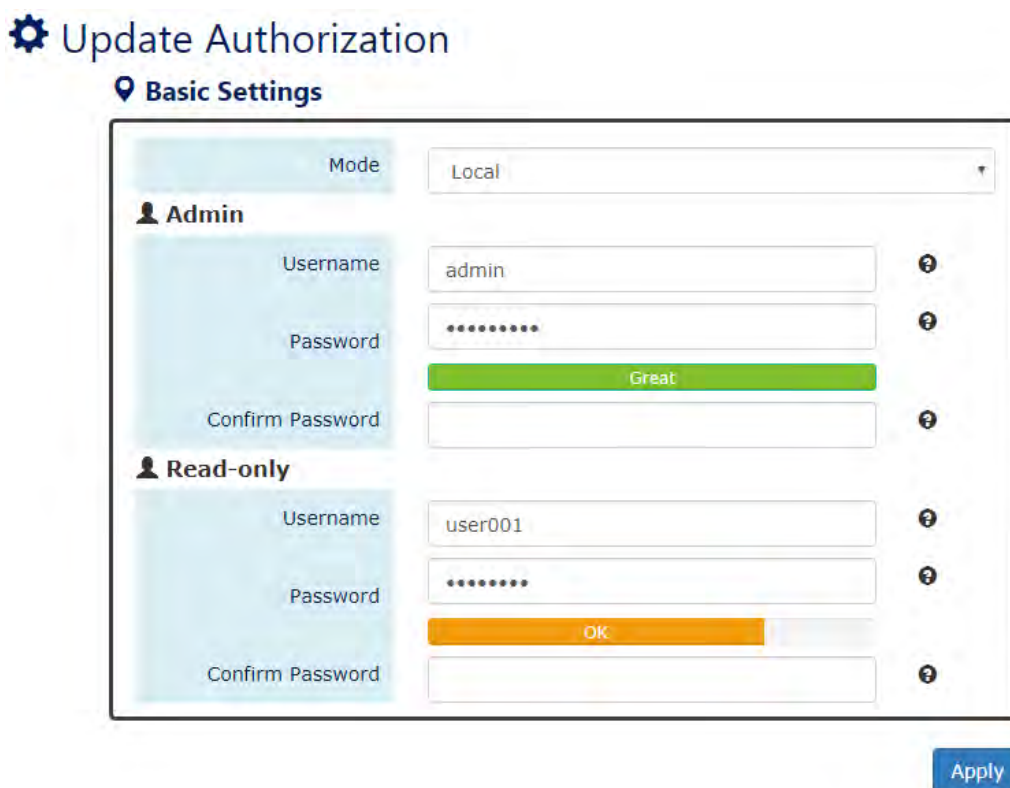

For more information, hover the mouse over the  icon in the system.

- **Mode**

There are three modes for login authentication.

Local: The username and password are defined in the system. Currently we support two-level users – **Admin** and **Read-only** user. The Admin can access any page and configure the system but the read-only user can only access status pages.

Radius: The username and password are defined in the **RADIUS server** and when users login the system, the system will authenticate with the RADIUS server to get the login permission. The password will be encrypted during the transmitting.

Tacacs+: The username and password are defined in the **TACACS+ server** and when users login the system, the system will authenticate with the TACACS+ server to get the login permission. The whole payload and password will be encrypted during the transmitting.

- **Username**

The account used to login to the system.

The maximum length of the Username is **32** characters

Only **alphabet** (A-Z, a-z) and **numbers** (0-9) are allowed.

The default Username is **admin**.

- **Password**

The password used to login to the system. We provide **password strength** bar for reference. There are 3 levels - **Weak**, **OK**, and **Great**. We strongly recommend users configuring the password to “**Great**” level for security.

The maximum length of the Password is **32** characters.

Only **alphabet** (A-Z, a-z), **numbers** (0-9), and **chars** (!,@,%^*,(,)) are allowed.

The default Password is **admin**.

- **Confirm Password**

It is used to confirm the value specified by the users in the "Password" field. The value of the field must be the same as "Password".





-  (Apply Button)

After configuring above fields, click "**Apply**" button to make the changes effective.

CONFIGURE RADIUS SERVER INFORMATION

This section only display when the mode in the Basic Settings is set to “Radius”.

RADIUS Server

Server IP	<input type="text"/>	
Server Port	<input type="text" value="1812"/>	
Shared Key	<input type="text"/>	
Retransmit Times	<input type="text"/>	
Timeout	<input type="text" value="5"/>	



For more information, hover the mouse over the  icon in the system.

- **Server IP**

The IP address of the RADIUS server must in the same subnet as the IP address of the switch.

- **Server Port**

The port is listening to the RADIUS service on the RADIUS server.

The range of the Server Port is **from 1 to 65535**.

The default Server Port is **1812**.

- [Shared Key](#)

The Shared Key is a string that used to build the connection with the RADIUS server. It must be the same as the string/secret set in the RADIUS server.

The maximum length of the Shared Key is **32** characters.

- [Retransmit Times](#)

The password used to login to the system.

The range of the Retransmit Times is **from 1 to 1000**.

- [Timeout](#)

The time interval is used to waiting for the response from the RADIUS server.

The range of the Timeout is **from 1 to 1000** seconds.

The default Timeout is **5** seconds.





- [Apply](#) (Apply Button)

After configuring above fields, click "**Apply**" button to make the changes effective.

CONFIGURE TACACS+ SERVER INFORMATION

This section only display when the mode in the Basic Settings is set to "Tacacs+".

TACACS+ Server

Server IP	<input type="text"/>	
Server Port	<input type="text" value="49"/>	
Shared Key	<input type="text"/>	
Timeout	<input type="text" value="30"/>	

[Apply](#)

For more information, hover the mouse over the  icon in the system.

- [Server IP](#)

The IP address of the TACSCS+ server must in the same subnet as the IP address of the switch.

The system supports both **IPv4** and **IPv6** addresses for the TACACS+ server.

- [Server Port](#)

The port is listening to the TACSCS+ service on the TACSCS+ server.

The range of the Server Port is **from 1 to 65535**.

The default Server Port is **49**.

- [Shared Key](#)

The Shared Key is a string that used to build the connection with the TACSCS+ server. It must be the same as the string/secret set in the TACSCS+ server.

The maximum length of the [Shared Key](#) is **32** characters.

- [Timeout](#)

The time interval is used to waiting for the response from the TACSCS+ server.

The range of the [Timeout](#) is **from 1 to 1000** seconds.

The default [Timeout](#) is **30** seconds.

-  (Apply Button)

After configuring above fields, click "**Apply**" button to make the changes effective.

Firmware Upgrade

For a better performance and wider industrial applications, we constantly develop new features and revise the issues from the users. We suggest the users to upgrade the system to the newest firmware version to have a better user experience.

We provide 2 ways to upgrade the firmware from the Web Console, - one is saving the firmware file in the USB stick and another one is save the firmware file on the PC. If the firmware file is on the PC, the users will have to only **select the file** and click **Apply** button, for the system to upgrade it automatically.

UPGRADE FIRMWARE VERSION - UPLOAD FIRMWARE FILE

Firmware Upgrade

Upload Firmware File

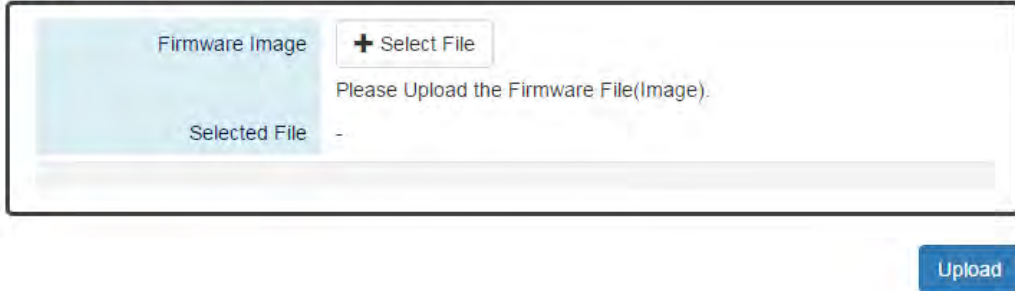

- [Firmware Image](#)
Click the "**Select File**" button to select the firmware image provided by the sales or support. The **Firmware Version** displayed on the system can be customized by the **file name**. For example, if you want the version to be called as 1.2.3, you only need to modify the file name to **XXX-v1.2.3** (XXX is the original file name).
- [Selected File](#)
After selecting a firmware image to be uploaded, the **selected file name** will be displayed in this field.
-  (Upload Button)
After selecting the firmware image, click "Upload" button to upload it.

UPGRADE FIRMWARE PROCESS - UPLOADING FIRMWARE FILE

The following steps are performed when the system starts to upgrade after the "Apply" button is clicked:

1. **Uploading** the firmware image

The progress bar displays the uploading percentage.

Upload Firmware File

Uploading... Please Wait.

The screenshot shows a web interface for uploading a firmware file. It features a light blue header with a location pin icon and the text "Upload Firmware File". Below this, a red heading reads "Uploading... Please Wait.". The main content area is a white box with a light blue background. On the left, there are two labels: "Firmware Image" and "Selected File". To the right of "Firmware Image" is a button with a plus sign and the text "Select File". Below this button is the instruction "Please Upload the Firmware File(Image)". To the right of "Selected File" is the text "WEBFULL-v0.0.14.1214". At the bottom of the white box is a green progress bar that is filled to the 56% mark. Below the white box is a blue button with the text "Upload".

2. **Verifying** the uploaded file

When the file is **100%** uploaded, the system starts to **verify** the uploaded file to make sure it is **valid**. By default, the firmware image is encrypted to prevent the attack on man-in-the-middle. Optionally, higher encryption methodology is also provided.

Upload Firmware File

Uploading Finished, Verifying Uploading File...

The screenshot shows the same web interface as above, but the progress bar is now filled to the 100% mark. The red heading now reads "Uploading Finished, Verifying Uploading File...". The "Upload" button remains visible below the interface.

3. **Installing** the uploaded firmware image

The new firmware will install after the system validates it.

Upload Firmware File

Verifying Finished, Installing Firmware...

The screenshot shows the same web interface as above, but the progress bar is now filled to the 100% mark. The red heading now reads "Verifying Finished, Installing Firmware...". The "Upload" button remains visible below the interface.

4. Rebooting the system

The system will reboot automatically if the firmware is upgraded without any issue.
The progress bar displays the rebooting progress.

Device Rebooting... Please Wait...

The Web Page Will Refresh Automatically.



UPGRADE FIRMWARE VERSION - COPY FIRMWARE FILE FROM USB

📍 Copy Firmware File from USB

Image File Name	<input type="text"/>
Please Enter the File(Image) Name Which is Saved in the USB.	

Upload

- **Image File Name**

Enter the name of the firmware image in the USB. The system will try to identify the file with specified file name to upload it to the system.

Note: The file system of USB must be FAT32.

- **Upload** (Upload Button)

After entering the firmware image name, click "Upload" button to copy it from the USB to the system.

UPGRADE FIRMWARE PROCESS - COPY FIRMWARE FILE FROM USB

1. Copying the firmware image from USB to switch

The system will also check if the USB is inserted and file exists.

📍 Copy Firmware File from USB

🌀 Copying Image to System...

Image File Name	<input type="text" value="WEBFULL-v0.0.14.1214"/>
Please Enter the File(Image) Name Which is Saved in the USB.	

Upload

2. Verifying the uploaded file

After copying the firmware file to switch, the system starts to **verify** the uploaded file to make sure it is **valid**. By default, the firmware image is encrypted to prevent the attack on man-in-the-middle. Optionally, higher encryption methodology is also provided.

📍 Copy Firmware File from USB

🌀 Copying File Finished, Verifying Uploading File...

Image File Name	WEBFULL-v0.0.14.1214 
Please Enter the File(Image) Name Which is Saved in the USB.	

Upload

3. Installing the uploaded firmware image

The new firmware will install after the system makes sure it is valid.

📍 Copy Firmware File from USB

🌀 Verifying Finished, Installing Firmware...

Image File Name	WEBFULL-v0.0.14.1214 
Please Enter the File(Image) Name Which is Saved in the USB.	

Upload

4. Rebooting the system

The system will reboot automatically if the firmware is upgraded without any issue. The progress bar displays the rebooting progress.

Device Rebooting... Please Wait...

The Web Page Will Refresh Automatically.



Config Backup

In the normal application, there are several switches in the Network and they might be configured to the same features. To facilitate this, the users can configure one of the switches and save the configuration file to localhost (for example: users' PC) or USB sticks and then restore the configurations on another switch via "**Config Restore**" function. Configuration file in the USB can also have a way to fast replace the device when it is damage.

BACKUP CONFIGURATION FILE

⚙️ Config Backup

📍 Backup to Localhost

File Name	<input type="text"/>	Save
-----------	----------------------	------

📍 Backup to USB

Backup Running-config File	<input type="text"/>	Save
Backup Startup-config File	<input type="text"/>	Save

- [Backup to Localhost](#)
 - [File Name](#)
Specify the File Name for the **Startup-config** file, which will be saved to the localhost.
- [Backup to USB](#)
Ensure there is a **USB stick** inserted into the USB port.
 - [Backup Running-config File](#)
Specify the File Name for the saved **Running-config** file, which will be saved to the USB.
 - [Backup Startup-config File](#)
Specify the File Name for the saved **Startup-config** file, which will be saved to the USB.

Note: The file system of USB must be [FAT32](#).

The "space" is not allowed in the File Name.

-  (Save Button)

Click the "Save" button to save the configuration file to the **Localhost** or **USB**.

NOTE: If the **File Name** filed is empty, the system assigns the default name: **config-[datetime].cfg**

Config Restore

We suggest users to save/backup the configurations after a series of settings. If another device needs the same configurations, users can use the **Config Restore** function to restore it.

RESTORE CONFIGURATION FILE



- [Restore from Localhost](#)
 - [File Name](#)
Select the configuration file, which is saved in the Localhost.
- [Restore from USB](#)
Please ensure there is a **USB stick** inserted into the USB port.
 - [File Name in USB](#)
The File Name of the saved configuration file, which is saved to the USB. If the configuration file is saved in the directory, please specify the **full path**.

Note: The file system of USB must be FAT32.
The “space” is not allowed in the File Name.
- [Restore](#) (Restore Button)
Click the "Restore" button to restore the configurations from the **Localhost** or **USB**.

USB Auto-Load & Auto-Backup

CONFIGURE USB AUTO-LOAD AND AUTO-BACKUP

Auto Load & Backup

USB Auto-Load	<input checked="" type="radio"/> Enable	<input type="radio"/> Disable
USB Auto-Backup	<input type="radio"/> Enable	<input checked="" type="radio"/> Disable

Apply

- USB Auto-Load**

“Enable” or “Disable” the USB Auto-Load function. If “USB Auto-Load” is **enabled**, the system will search the configuration file named “**startup-config**” in the USB and load it when rebooting.

Note: The file system of USB must be FAT32.
- USB Auto-Backup**

“Enable” or “Disable” USB Auto-Backup function. If “USB-Auto-Backup” is **enabled**, the system will save the configurations to a file named “**running-config**” in the USB when users modify the configurations.

Note: The file system of USB must be FAT32.
-  (Apply Button)

After configuring above fields, click "**Apply**" button to make the changes effective.

Command & Control Node

Command & Control Node (CCN) provides firmware upgrading for batch of switches at once. Currently, the CCN function can upgrade maximum 10 nodes at the same time. With CCN function, administrators can work more efficient and save a lot of time.

The **CCN** function is supported on any kind of topologies, such as ring, linear, mesh, star... etc. The following diagram is an example with ring topology.

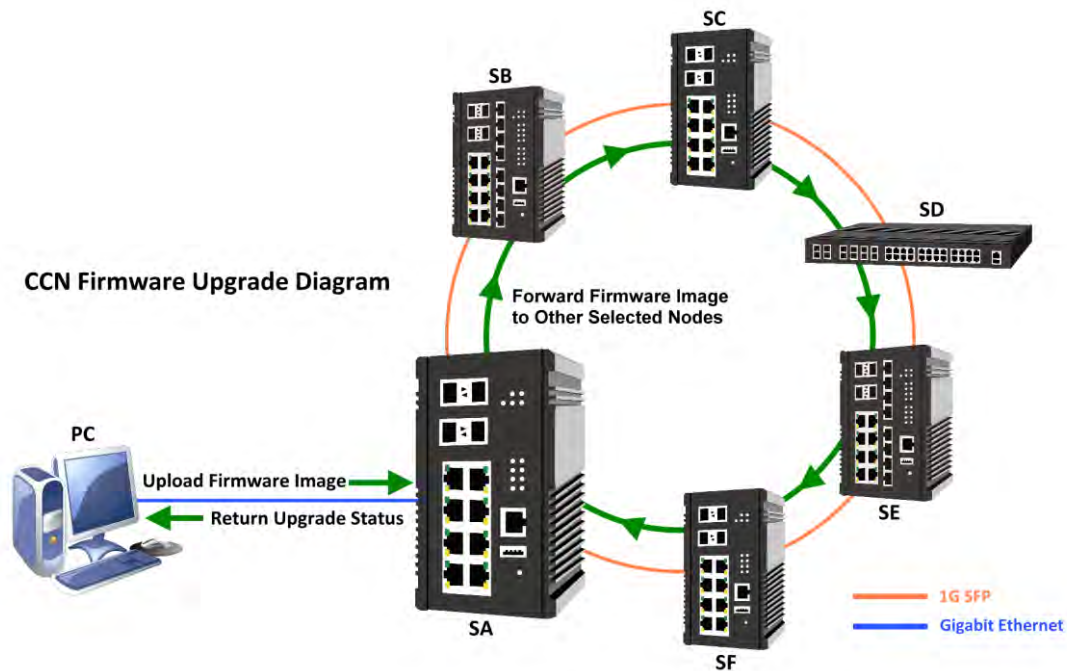

The **SA** Switch is the CCN master connected to PC, and from PC end, users can control the CCN function, such as selection of joined switches and firmware path configuration. The firmware image must be saved in the **USB** device. After clicking Upgrade button on CCN master, the **SA** starts upgrading its firmware if **SA** is selected and forwards the firmware image to other switches (**SB**, **SC**, **SD**, **SE**, or **SF**) that selected to join CCN. Once the switches receive the firmware image, they will also start upgrading their firmware automatically. That's why we say CCN can help administrators save their time and work more efficient.

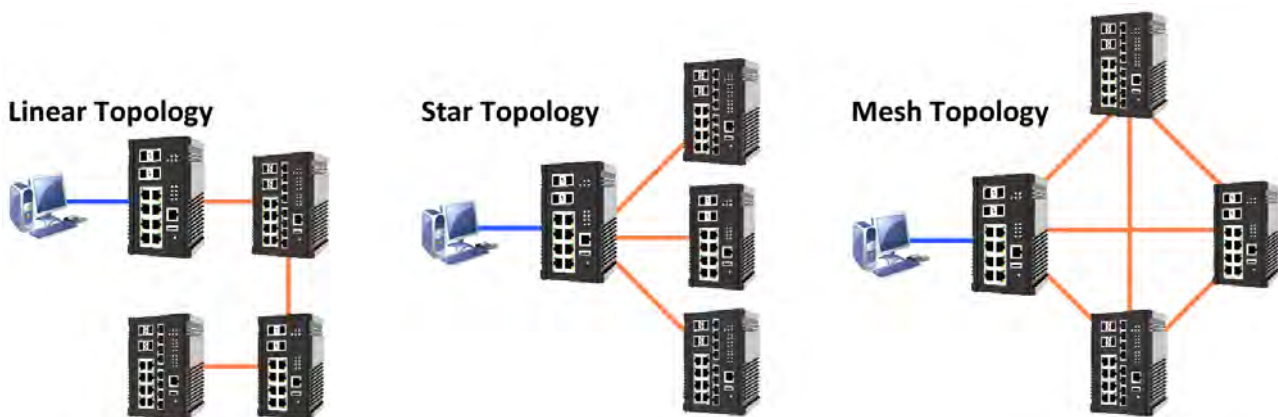

CONFIGURE COMMAND & CONTROL NODE (CCN)

⚙️ CCN Configuration

📍 Discovered Nodes

Show entries Search:

All <input type="checkbox"/>	MAC Address <input type="checkbox"/>	IP Address <input type="checkbox"/>	Firmware <input type="checkbox"/>	Stage <input type="checkbox"/>	% <input type="checkbox"/>
<input type="checkbox"/>	68:02:35:00:04:8B	192.168.10.18	ccn-host20-20200114.2259.19	-	-
<input type="checkbox"/>	68:02:35:01:EF:70	192.168.10.68	ccn-host20-20200114.2259.19	-	-
<input type="checkbox"/>	68:02:35:2F:4C:16	192.168.10.28	ccn-host20-20200114.2259.19	-	-
<input type="checkbox"/>	68:02:35:39:80:61	192.168.10.58	ccn-host20-20200114.2259.19	-	-
<input type="checkbox"/>	68:02:35:55:22:65	192.168.10.108	ccn-host20-20200114.2259.19	-	-
<input type="checkbox"/>	68:02:35:B7:89:05	192.168.10.33	ccn-host20-20200114.2259.19	-	-
<input type="checkbox"/>	68:02:35:CF:FE:73	192.168.10.1	1.1.71	-	-
<input type="checkbox"/>	68:02:35:EF:2B:3F	192.168.10.88	ccn-host20-20200114.2259.19	-	-

Showing 1 to 8 of 8 entries First Previous Next Last

📍 Upgrade Selected Hosts

Image File Name

- [Discovered Nodes](#)

- [All / Select Box](#)

Click “All” to select or de-select all of the discovered nodes. Click **Select Boxes** to select some of the discovered nodes to upgrade their firmware.

Note-1: Please select **at least one node** to do CCN upgrade

Note-2: Please select **at most 10 nodes** to do CCN upgrade.

- [MAC Address](#)

The **MAC Address** of the designated discovered node

- [IP Address](#)

The **IP Address** of the designated discovered node

- [Firmware](#)

The current **Firmware Version** of the designated discovered node

- [Stage](#)

After clicking Upgrade button, the upgrading stage will display on this field. The following table displays the all stages.

Stage	Description
IDLE	The initial stage of CCN operation
DATA_RECV	The host is receiving the firmware image
UPDATING	The firmware image is received and start upgrading
FINISHED	Firmware upgrading is finished
ERROR	Firmware upgrading is failed
DISCONN	The host disconnects with CCN master

- [%](#)

The operating percentage of current stage

- [Upgrade Selected Hosts](#)

Please ensure there is a **USB stick** inserted into the USB port.

- Image File Name

The File Name of the firmware image, which is saved to the USB. The firmware image **MUST** be saved in the **root path** of USB.

Note: The file system of USB must be FAT32.

- **Upgrade** (Upgrade Button)

After entering the firmware image path, click "Upgrade" button to start upgrading.

CONFIGURATION EXAMPLE FOR CCN

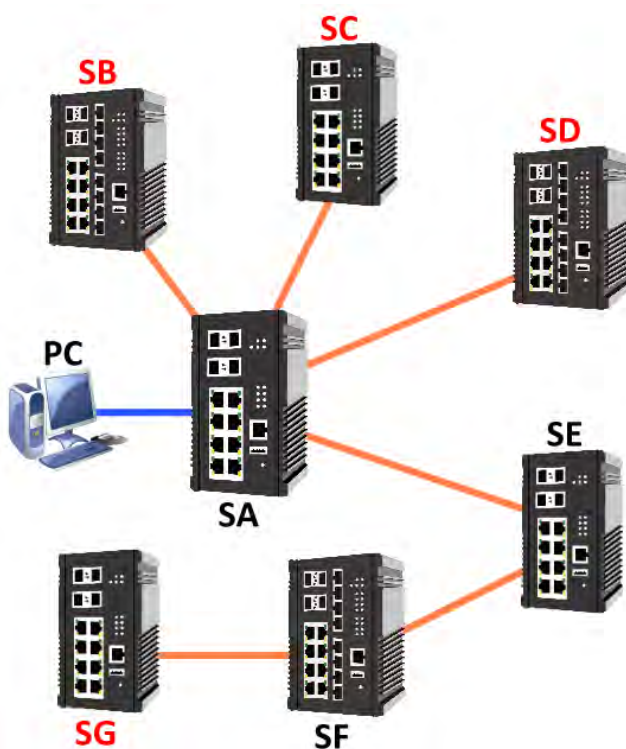

In the left diagram, the **SA** is the **CCN master**, and the **SB**, **SC**, **SD**, and **SG** are the nodes that want to upgrade.

First, we have to ensure the firmware image is saved in a USB stick and the USB stick is inserted into the USB port of SA.

And then, open the configuration WEB GUI of **SA** and enter **Command & Control Node** page. The connected nodes will show on the **Discovered Nodes** list.

Step-by-step Configuration

9. Login Web Console and click menu "Maintenance" -> "Command & Control Node"
10. The Discovered Nodes section displays all devices that **SA** (master) can connect to.
11. Click the checkboxes of **SB**, **SC**, **SD**, and **SG** (or the devices that want to upgrade).

Note: There is a limitation that users have to select the devices that want to upgrade **at once** and **on the same page** and then click upgrade button to start.

Discovered Nodes

Show entries Search:

All	MAC Address	IP Address	Firmware	Stage	%
<input checked="" type="checkbox"/>	68:02:35:00:04:8B	192.168.10.18	1.1.63	-	-
<input checked="" type="checkbox"/>	68:02:35:01:EF:70	192.168.10.68	1.1.63	-	-
<input checked="" type="checkbox"/>	68:02:35:2F:4C:16	192.168.10.28	1.1.63	-	-
<input checked="" type="checkbox"/>	68:02:35:39:80:61	192.168.10.58	1.1.63	-	-
<input type="checkbox"/>	68:02:35:55:22:65	192.168.10.108	1.1.69	-	-
<input type="checkbox"/>	68:02:35:B7:89:05	192.168.10.33	1.1.70	-	-
<input type="checkbox"/>	68:02:35:CF:FE:73	192.168.10.1	1.1.71	-	-
<input type="checkbox"/>	68:02:35:EF:2B:3F	192.168.10.88	1.1.69	-	-

Showing 1 to 8 of 8 entries First Previous Next Last

12. Check the **USB stick** is inserted and the firmware image is saved in it.

13. Enter the path of the firmware image.

Upgrade Selected Hosts

14. Click **Upgrade** Button to start upgrading

i. Configure Firmware File Name

Configure firmware file name completed. X

ii. Copying Firmware, there will be a warning message to notify users to keep the WEB on the CCN page.

WARNING: DO NOT leave or close this web page during upgrading !!!

Copying firmware ...

iii. Verifying Firmware

WARNING: DO NOT leave or close this web page during upgrading !!!

Verifying firmware ...

iv. Decompressing and Extracting Firmware

WARNING: DO NOT leave or close this web page during upgrading !!!

Decompressing and extracting ...

v. Start CCN Upgrading, the Stage and Percentage (%) will change with the upgrading process

vi. Stage *DATA_RECV*, hosts are receiving the firmware image

⚙️ CCN Configuration

WARNING: DO NOT leave or close this web page during upgrading !!!

📍 Discovered Nodes

Show entries Search:

All <input type="checkbox"/>	MAC Address	IP Address	Firmware	Stage	%
<input checked="" type="checkbox"/>	68:02:35:00:04:8B	192.168.10.18	1.1.63	DATA_RECV	0%
<input checked="" type="checkbox"/>	68:02:35:01:EF:70	192.168.10.68	1.1.63	DATA_RECV	0%
<input checked="" type="checkbox"/>	68:02:35:2F:4C:16	192.168.10.28	1.1.63	DATA_RECV	0%
<input checked="" type="checkbox"/>	68:02:35:39:80:61	192.168.10.58	1.1.63	DATA_RECV	0%
<input type="checkbox"/>	68:02:35:55:22:65	192.168.10.108	1.1.69	-	-
<input type="checkbox"/>	68:02:35:B7:89:05	192.168.10.33	1.1.70	-	-
<input type="checkbox"/>	68:02:35:CF:FE:73	192.168.10.1	1.1.71	-	-
<input type="checkbox"/>	68:02:35:EF:2B:3F	192.168.10.88	1.1.69	-	-

Showing 1 to 8 of 8 entries First Previous Next Last

vii. Stage *UPDATING*, the firmware is upgrading

⚙️ CCN Configuration

WARNING: DO NOT leave or close this web page during upgrading !!!

📍 Discovered Nodes

Show entries Search:

All <input type="checkbox"/>	MAC Address	IP Address	Firmware	Stage	%
<input checked="" type="checkbox"/>	68:02:35:00:04:8B	192.168.10.18	1.1.63	UPDATING	11%
<input checked="" type="checkbox"/>	68:02:35:01:EF:70	192.168.10.68	1.1.63	UPDATING	29%
<input checked="" type="checkbox"/>	68:02:35:2F:4C:16	192.168.10.28	1.1.63	UPDATING	27%
<input checked="" type="checkbox"/>	68:02:35:39:80:61	192.168.10.58	1.1.63	UPDATING	17%
<input type="checkbox"/>	68:02:35:55:22:65	192.168.10.108	1.1.69	-	-
<input type="checkbox"/>	68:02:35:B7:89:05	192.168.10.33	1.1.70	-	-
<input type="checkbox"/>	68:02:35:CF:FE:73	192.168.10.1	1.1.71	-	-
<input type="checkbox"/>	68:02:35:EF:2B:3F	192.168.10.88	1.1.69	-	-

Showing 1 to 8 of 8 entries First Previous Next Last

viii. Stage *FINISHED*, the firmware upgrading is finished, and the selected nodes are rebooting

⚙️ CCN Configuration

WARNING: DO NOT leave or close this web page during upgrading !!!

Rebooting all participant hosts

📍 Discovered Nodes

Show entries Search:

All <input type="checkbox"/>	MAC Address	IP Address	Firmware	Stage	%
<input checked="" type="checkbox"/>	68:02:35:00:04:8B	192.168.10.18	1.1.63	FINISHED	100%
<input checked="" type="checkbox"/>	68:02:35:01:EF:70	192.168.10.68	1.1.63	FINISHED	100%
<input checked="" type="checkbox"/>	68:02:35:2F:4C:16	192.168.10.28	1.1.63	FINISHED	100%
<input checked="" type="checkbox"/>	68:02:35:39:80:61	192.168.10.58	1.1.63	FINISHED	100%
<input type="checkbox"/>	68:02:35:55:22:65	192.168.10.108	1.1.69	-	-
<input type="checkbox"/>	68:02:35:B7:89:05	192.168.10.33	1.1.70	-	-
<input type="checkbox"/>	68:02:35:CF:FE:73	192.168.10.1	1.1.71	-	-
<input type="checkbox"/>	68:02:35:EF:2B:3F	192.168.10.88	1.1.69	-	-

Showing 1 to 8 of 8 entries First Previous Next Last

SFTP File Access

CONFIGURE SFTP FIRMWARE UPGRADE

```
Switch(config)# upload server sftp
  account          Set uploading server account
  password         Set uploading server password

Switch(config)# upload sftp
Usage: upload sftp [<cr>]
```

1. Config file name for upgrade

```
Switch(config)# upload file name [FILE_NAME]
```

2. Config IP address of SFTP server

```
Switch(config)# upload server ip [SERVER_IP]
```

3. Config login account name of SFTP server

```
Switch(config)# upload sftp server account [SERVER_ACCOUNT]
```

4. Config login account password of SFTP server

```
Switch(config)# upload sftp server password [SERVER_PASSWORD]
```

5. Action to do the SFTP upload

```
Switch(config)# upload sftp
```

CONFIGURE SFTP CONFIGURATION RESTORE

```
Switch(config)# copy sftp
  account          set sftp server account
  file             Set uploading file
  ip               set sftp server ip
  password         set sftp server password
  startup-config   Destination
  usb              Destination
```

1. Config IP address of SFTP server

```
Switch(config)# copy sftp ip [SERVER_IP]ssh
```

2. Config login account name for SFTP server

```
Switch(config)# copy sftp account [SERVER_ACCOUNT]
```

3. Config login account password of SFTP server

```
Switch(config)# copy sftp password [SERVER_PASSWORD]
```

4. Config file name for upgrade in the SFTP server

```
Switch(config)# copy sftp file name [FILE_NAME]
```

5. Action to do the SFTP download to the startup configuration

```
Switch(config)# copy sftp startup-config
```

Note: After copy to the startup configuration, system will reboot automatically.

6. Action to do the SFTP download to the USB storage

```
Switch(config)# copy sftp USB
```

Note: The file system of USB must be FAT32.

Command Line Interface

Command Line Interface is usually called **CLI**. It allows the users to configure, monitor, and maintain the switch by executing commands directly.

CONNECT TO CLI VIA CONSOLE PORT

Before starting the connection to the Console Port, ensure that you have a utility (such as “Putty”, “Tera Term”, “HyperTerminal”, “SecureCRT”, etc.) to do that. The following example is operating on **Windows 7** and connected by “**Putty**”.

1. Connect the Console Port to your PC or Laptop and check the port number in the “Device Manager” on the PC.

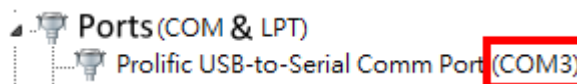

2. Configure the Serial Information with the COM port number and Speed (Baud Rate: **115200**). By default, the Data bits and Parity are **8** and **1**. Then click “Open” to connect to the CLI.

Note: The complete parameters are **COMX/115200/8/1**.

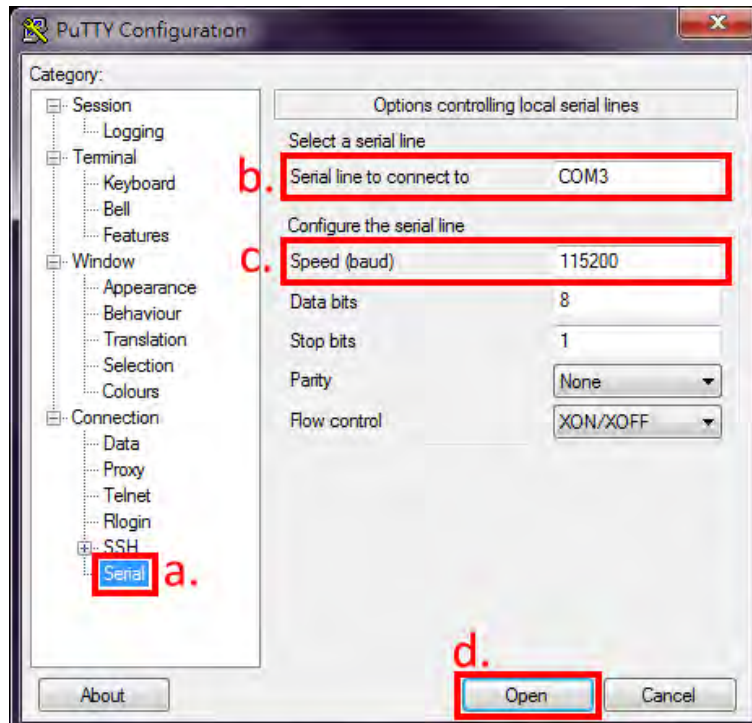

3. Enter the username and password to login to the system. The default username and password is **admin/admin**.

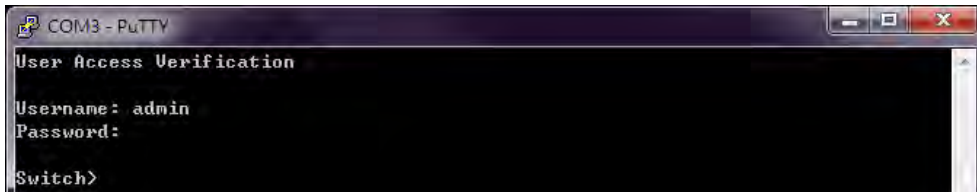

4. When you see “**Switch>**”, it refers that you have logged in to the system. You can then start to configure the system on the CLI mode.

CONNECT TO CLI VIA TELNET

The following example is operating on **Windows 7**. If the system shows the information as the picture below, please enable the “Telnet Client” before using telnet function.

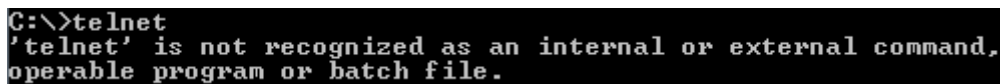

1. Click Windows “Start” button and enter “cmd” on the search box to open the “Command Prompt”.
2. Enter “**telnet [IP_ADDRESS]**” on the CMD window. For example, the IP address of the switch is “192.168.10.166”, so enter “telnet 192.168.10.166” and then press the “Enter” key.

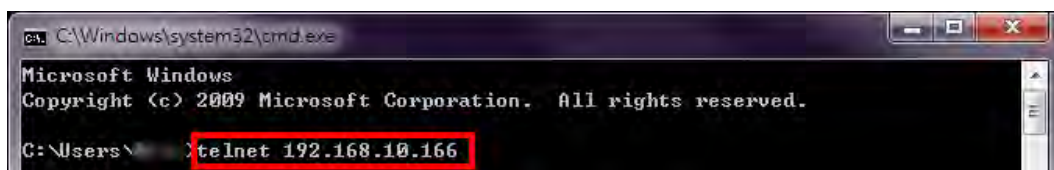

3. Enter the username and password to login the system. The default username and password is **admin/admin**.

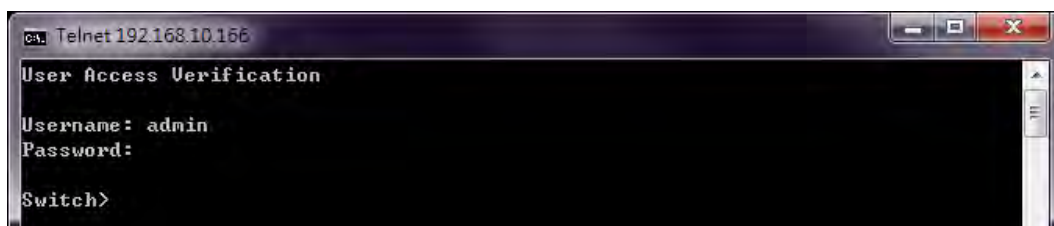

4. When “**Switch>**” is displayed, it refers that you have logged in to the system. You can then start to configure the system on the CLI mode.

CONFIGURE SYSTEM UNDER DIFFERENT MODES

After login to CLI, users have to enter the Privileged Mode for “show” commands. If users want to configure the system via CLI, they have to enter Configuration Mode.

The command to enter Privileged Mode is “**enable**”. After enter Privileged Mode, issue “**configure terminal**” to enter Configuration Mode. When “**Switch(config)#**” is displayed, users can start configuring the system with all commands under Configuration Mode. In the Command Group section, the mode of each command will be marked in the last column of the commands table.



There are different modes under Configuration Mode, such as **Interface Mode**, **VLAN Mode**, **ERPS Mode**, and **MRP Mode**. If the command that users are preparing to issue is under these modes, they have to enter the designated mode first. Users can issue “**exit**” to leave current mode. In the following table, we list the commands to enter different modes.

Mode	Command	Description
Interface	interface lanX	X implies the port number
VLAN	vlan X	X implies the VLAN ID
ERPS	ethernet redundancy erps-ring X	X implies the Ring number, from 1 to 3
MRP	ethernet redundancy mrp instance-mode 1	Only support single ring currently

ENABLE TELNET CLIENT ON WIDOWS 7

1. Click the Windows “Start” button and click “Control Panel” item.

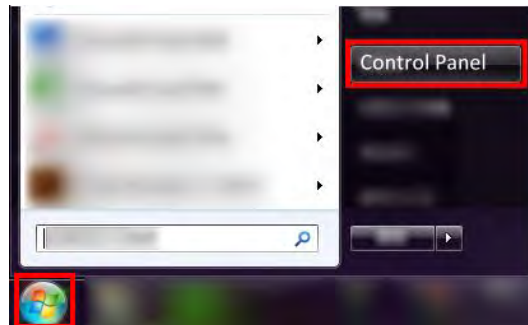

2. Click the “Programs” item.



3. Click the “Turn Windows features on or off” item.



4. Select the checkbox for the Telnet Client function.

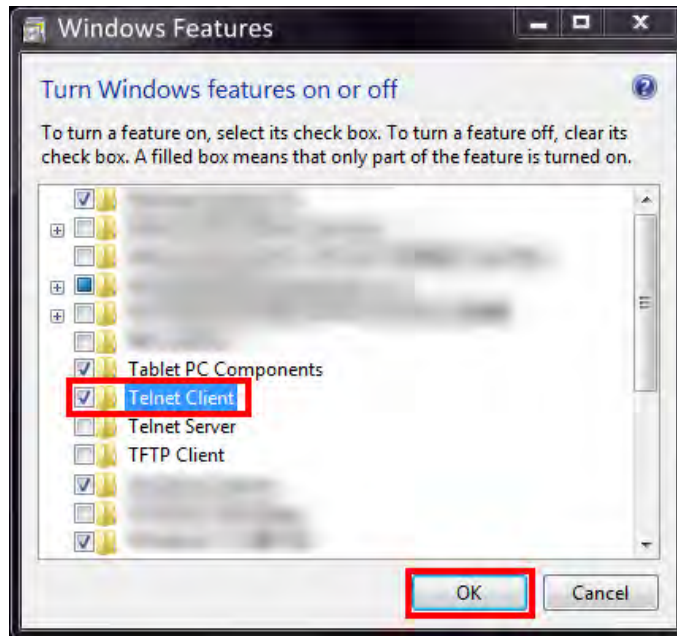

5. Click Windows “Start” button and enter “cmd” on the search box to open the “Command Prompt” to test the telnet function.

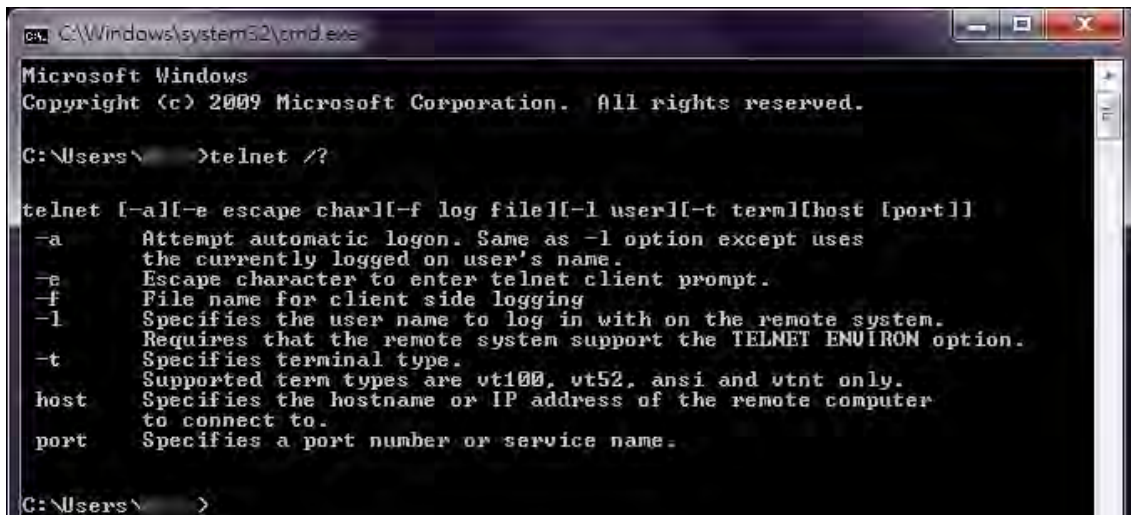

FIRMWARE UPGRADE VIA CLI

Users can upgrade the system with a new firmware on both the web console and CLI mode. To upgrade on the web console, a high interactivity web GUI is provided for the users. Please refer to [Firmware Upgrade](#) section. To upgrade on the CLI mode, there are 3 methods: TFTP, wget (HTTP), and USB. The following sections explain how to upgrade the firmware using the 3 methods.

FIRMWARE UPGRADE VIA CLI – TFTP

If the users are planning to upgrade the firmware via CLI mode with TFTP, a **TFTP server** is needed before upgrading. You can download the free TFTP server from [tftpd official website](http://tftpd-official-website).

1. Open the TFTP Server and browser the file directory path. For example, if the firmware file is saved on the desktop, the path to the desktop should be specified in the “**Current Directory**” field.

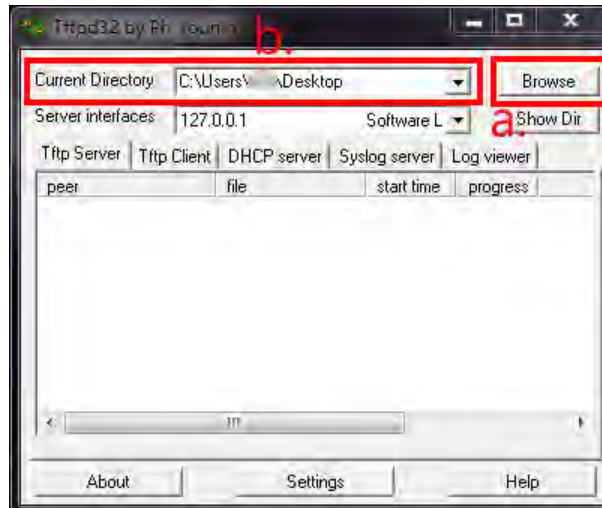

2. Make sure the link between the switch and the host (PC or laptop) is connected. To verify it, ping the IP address of the switch IP address from the host to check it.
3. Assign the **firmware file name** by issuing the “**upload file name [FILE_NAME]**”. The default file name is “WEBFULL”.
4. Assign the TFTP Server IP address by issuing “**upload server ip [SERVER_IP]**”. The server IP address is the IP address of the host, which is running the TFTP server.

The commands for assigning the filename and server IP are in the **Configure mode**, so before configuring, specify “**configure terminal**” to enter the **Configure mode**.

If the command is completely configured, the system will display “**OK**”.

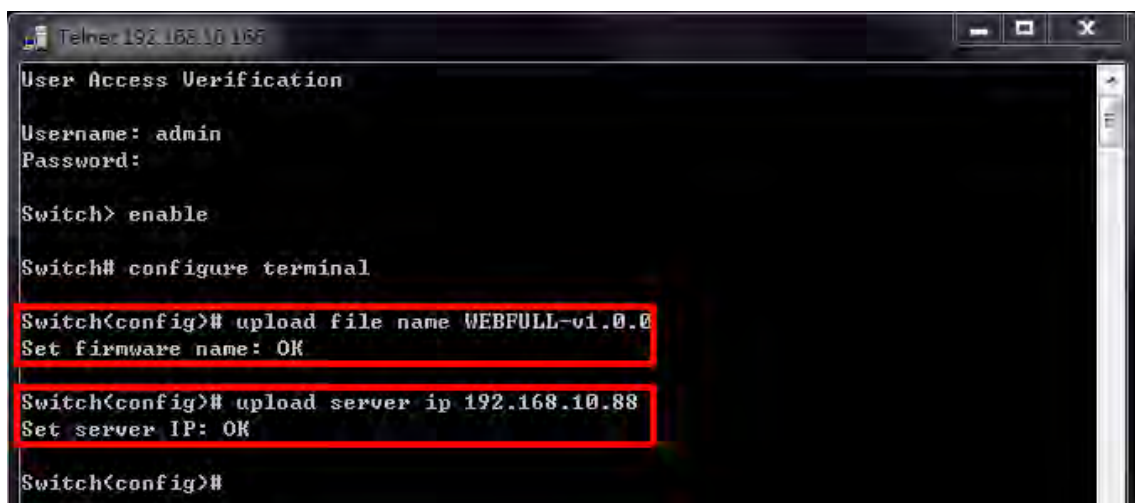

5. Start to upgrade the firmware file by specifying “upload tftp”. The system starts to upload the assigned file by the TFTP. This takes a few minutes.

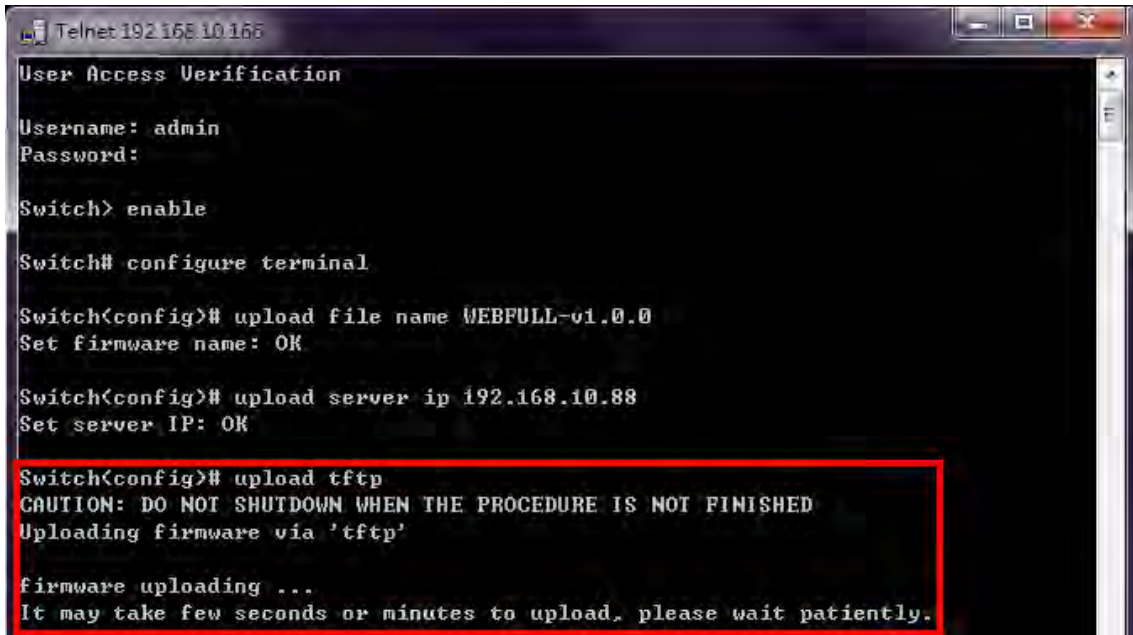

```
Telnet 192.168.10.166
User Access Verification
Username: admin
Password:
Switch> enable
Switch# configure terminal
Switch(config)# upload file name WEBFULL-v1.0.0
Set firmware name: OK
Switch(config)# upload server ip 192.168.10.88
Set server IP: OK
Switch(config)# upload tftp
CAUTION: DO NOT SHUTDOWN WHEN THE PROCEDURE IS NOT FINISHED
Uploading firmware via 'tftp'
firmware uploading ...
It may take few seconds or minutes to upload, please wait patiently.
```

6. After uploading, the system will **verify** the uploaded file. If the verification passes, the new firmware file will be installed. Ensure the system is **powered on** and the system will **reboot** automatically after the firmware is completely installed.

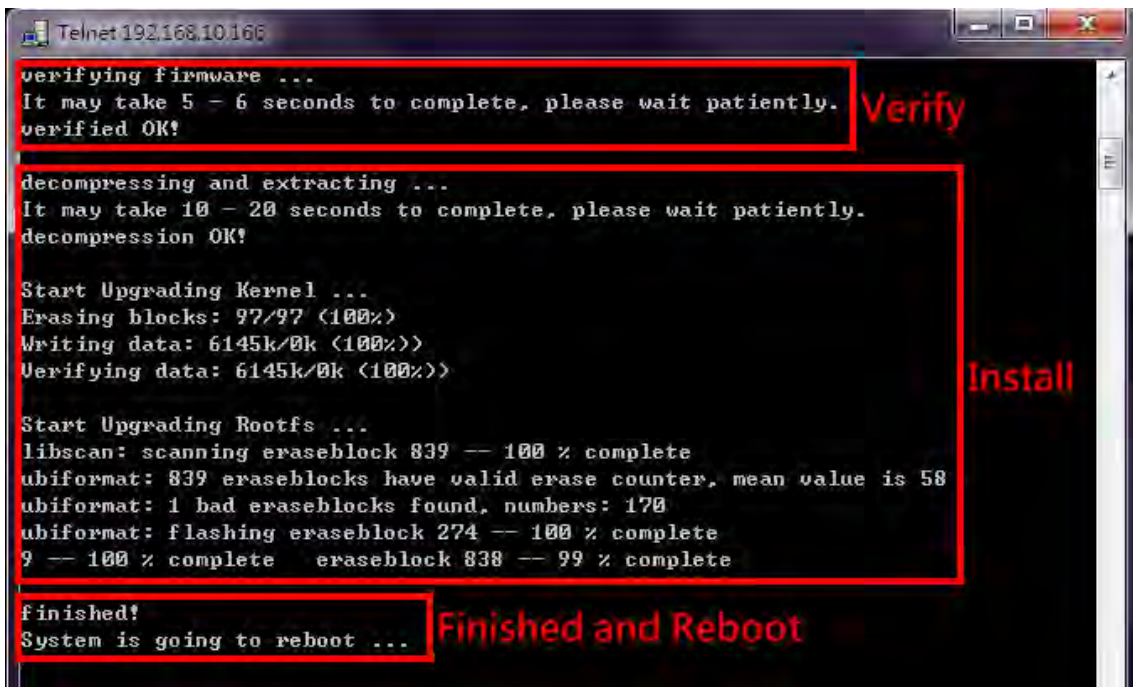

```
Telnet 192.168.10.166
verifying firmware ...
It may take 5 - 6 seconds to complete, please wait patiently.
verified OK!
decompressing and extracting ...
It may take 10 - 20 seconds to complete, please wait patiently.
decompression OK!
Start Upgrading Kernel ...
Erasing blocks: 97/97 (100%)
Writing data: 6145k/0k (100%)
Verifying data: 6145k/0k (100%)
Start Upgrading Rootfs ...
libscan: scanning eraseblock 839 -- 100 % complete
ubiformat: 839 eraseblocks have valid erase counter, mean value is 58
ubiformat: 1 bad eraseblocks found, numbers: 170
ubiformat: flashing eraseblock 274 -- 100 % complete
9 -- 100 % complete eraseblock 838 -- 99 % complete
finished!
System is going to reboot ...
```

FIRMWARE UPGRADE VIA CLI – WGET

“Wget” uses the HTTP to transmit the file to the switch. Users have to establish a HTTP Server such as “[Apache](#)” and upload the firmware file to the HTTP Server.

1. Assume there is a HTTP Server existed whose IP address is “192.168.1.9” and the firmware file named **WEBFULL-v1.0.0** is uploaded.
2. Make sure the link between the switch and the server is connected. We can ping the IP address of the server from the switch by using the command “**ip ping [IP_ADDRESS]**”.
3. Assign the **firmware file name** by using “**upload file name WEBFULL-v1.0.0**”.
4. Assign the **Wget Server IP address** by using “**upload server ip 192.168.1.9**”.

If the command is completely configured, the system will display “OK”.

```

Telnet 192.168.1.166
User Access Verification
Username: admin
Password:
Switch> enable
Switch# configure terminal
Switch(config)# upload file name WEBFULL-v1.0.0
Set firmware name: OK
Switch(config)# upload server ip 192.168.1.9
Set server IP: OK
Switch(config)#
    
```

5. Start to upgrade the firmware file by using “upload wget”. The system starts to upload the assigned file by HTTP. This takes a few seconds or minutes.

```

Telnet 192.168.1.166
User Access Verification
Username: admin
Password:
Switch> enable
Switch# configure terminal
Switch(config)# upload wget
CAUTION: DO NOT SHUTDOWN WHEN THE PROCEDURE IS NOT FINISHED
Uploading firmware via 'wget'
Firmware uploading ...
It may take few seconds or minutes to upload, please wait patiently.
Connecting to 192.168.1.9 (192.168.1.9:80)
WEBFULL-v1.0.0 100% !*****! 27940k 0:00:00 ETA
    
```

- Once the uploading is complete, the system will **verify** the uploaded file. If the verification passes, the new firmware file will be installed. Ensure to keep the system **powered on** and the system will **reboot** automatically after the firmware is completely installed.

```

Telnet 192.168.1.166
verifying firmware ...
It may take 5 - 6 seconds to complete, please wait patiently.
verified OK!

decompressing and extracting ...
It may take 10 - 20 seconds to complete, please wait patiently.
decompression OK!

Start Upgrading Kernel ...
Erasing blocks: 97/97 (100%)
Writing data: 6145k/0k (100%)
Verifying data: 6145k/0k (100%)

Start Upgrading Rootfs ...
libscan: scanning eraseblock 839 -- 100 % complete
ubiformat: 839 eraseblocks have valid erase counter, mean value is 58
ubiformat: 1 bad eraseblocks found, numbers: 170
ubiformat: flashing eraseblock 274 -- 100 % complete
9 -- 100 % complete   eraseblock 838 -- 99 % complete

finished!
System is going to reboot ...
  
```

FIRMWARE UPGRADE VIA CLI – USB

Check if the firmware file is saved in the USB and the USB stick is inserted in the USB part of the switch before upgrading the firmware file.

- Save the firmware file to the USB device and insert the USB stick to the USB port.
- Use “copy usb firmware [FILE_NAME]” to upgrade the system via USB.

```

Telnet 192.168.10.166
User Access Verification
Username: admin
Password:
Switch> enable
Switch# configure terminal
Switch(config)# copy usb firmware WEBFULL-v1.0.0
Start FW Install.....!
  
```

- After the installation is complete, the system will reboot automatically.

Note: The file system of USB must be FAT32.

COMMAND GROUPS

The following are the commands that the users can use in the CLI mode. Please check if the **mode** is correct before issuing the command.

AUTHENTICATION GROUP

Command	Explanation	Mode
login authentication [tacacs+ radius]	Set login authentication method	Configure
logout	Disconnect	Configure
radius-server host [IP_ADDR]	Set IP address of RADIUS server	Configure
radius-server key [SHARED_KEY]	Set specific characters for authentication verification	Configure
radius-server port [1-65535]	Set communication port of RADIUS server	Configure
radius-server retransmit [1-1000]	Set the number of times a request re-sending to RADIUS server	Configure
radius-server timeout [1-1000]	Set the timeout period to wait for RADIUS server response	Configure
tacacs-server host [IP_ADDR]	Set IP address of TACASC+ server	Configure
tacacs-server key [SHARED_KEY]	Set specific characters for authentication verification	Configure
tacacs-server port [1-65535]	Set communication port of TACASC+ server	Configure
tacacs-server timeout [1-1000]	Set the timeout period to wait for TACASC+ server response	Configure
username [USER_ID] [PASSWORD]	Configure username and password	Configure
username-ro [USER_ID] [PASSWORD]	Configure read only username and password	Configure
show login authentication	Display login authentication method	Configure
show radius-server host	Display IP address of RADIUS server	Configure
show radius-server key	Display specific characters for authentication verification	Configure
show radius-server port	Display communication port of RADIUS server	Configure
show radius-server retransmit	Display the number of times a request is resent	Configure
show radius-server timeout	Display the timeout period to wait for RADIUS server response	Configure
show tacacs-server host	Display IP address of the server	Configure
show tacacs-server key	Display specific characters for authentication verification	Configure
show tacacs-server port	Display communication port of the server	Configure
show tacacs-server timeout	Display the timeout period to wait for the server response	Configure
show username	Display admin ID	Configure
show username-ro	Display read only user ID	Configure
no login authentication	Default Login authentication method	Configure
no radius-server host	Default IP address of the server	Configure

no radius-server key	Default specific characters for authentication verification	Configure
no radius-server port	Default communication port of the server	Configure
no radius-server retransmit	Default the number of times a request is resent	Configure
no radius-server timeout	Default the timeout period to wait for the server response	Configure
no tacacs-server host	Default IP address of TACACS+ server	Configure
no tacacs-server key	Default specific characters for authentication verification	Configure
no tacacs-server port	Default communication port of TACACS+ server	Configure
no tacacs-server timeout	Default the timeout period to wait for TACACS+ server response	Configure
no username	Default username and password	Configure
no username-ro	Default read only username and password	Configure

SSH GROUP

Command	Explanation	Mode
copy host-key-config usb [FILE_NAME]	Backup SSH host key to USB	Configure
copy usb host-key-config [file]	Upload SSH host key config from USB	Configure
download file name [FILE_NAME]	Set downloading file name, default name is host_key.cfg	Configure
download host-key-config	Download current SSH host key config	Configure
download server account [SERVER_ACCOUNT]	Set downloading server account	Configure
download server ip [SERVER_IP]	Set downloading server IP Address	Configure
download server password [SERVER_PASSWORD]	Set downloading server password	Configure
upload host-key-config wget [file]	Upload SSH host key config from Localhost	Configure
show ssh host-key	Display SSH host key	Configure

SYSTEM GROUP

Command	Explanation	Mode
erase startup-config	Reset to factory default and reboot	Configure
erase startup-config keep-ip	Reset to factory default except IP	Configure
erase startup-config keep-ip-user	Reset to factory default except IP and USER	Configure
erase startup-config keep-user	Reset to factory default except USER ID/PASS	Configure
exec-timeout [MINUTE] [SECOND]	Set idle timeout [MINUTE] [SECOND]	Configure
hostname [HOSTNAME]	Set Switch Host Name	Configure
reboot	Reboot the switch	Configure
system contact [CONTACT]	Set system contact	Configure
system description [SYS_DESCRIPTION]	Set device description	Configure
system location [LOCATION]	Set device location	Configure

show exec-timeout	Display idle timeout	Configure
show hostname	Display Switch Host Name	Configure
show environment power [1 2]	Display power 1/2 status	Configure
show event status relay	Display relay status	Configure
show system contact	Display system contact	Configure
show system description	Display system description	Configure
show system firmware-date	Display system release time	Configure
show system location	Display system location	Configure
show system mac	Display system MAC address	Configure
show system uptime	Display system uptime	Configure
show system version firmware	Display system version	Configure
show system serial_number	Display system serial number	Configure
show transceiver ddm	Display transceiver DDM information	Interface
show transceiver info	Display transceiver information	Interface
show transceiver raw	Display transceiver raw data	Interface
show username	Display admin ID	Configure
show tech-support	Display FW version, link and running config for technical support	Configure
no exec-timeout	Default idle timeout	Configure
no hostname	Default Switch Host Name	Configure
no system contact	Clear system contact	Configure
no system description	Clear device description	Configure
no system location	Clear device location	Configure
no username	Default username and password	Configure

SERVICE CONTROL GROUP

Command	Explanation	Mode
service [http https ssh telnet console reset-button] enable	Enable service http, https, ssh, telnet, console port, or reset button	Configure
show service [http https ssh telnet console reset-button]	Display service http, https, ssh, telnet, console port, or reset button state	Configure
no service [http https ssh telnet console reset-button]	Disable service http, https, ssh, telnet, console port, or reset button	Configure

IPV4 GROUP

Command	Explanation	Mode
ip address [IP_ADDR] [MASK]	Set IPv4 address and netmask	Configure
ip default-gateway [DEFAULT_GATEWAY_ADDR]	Set default gateway address	Configure
ip name-server [NAME_SERVER_IP]	Set Domain Name-Server	Configure
ip ping [IPV4_ADDR] [<size PKG_SIZ> <repeat PKG_CNT>]	Issue an IPv4 ping command	Configure

show ip address	Display Host address of IPv4	Configure
show ip default-gateway	Display default gateway address	Configure
show ip mode	Display IP mode (Static or Dynamic)	Configure
show ip name-server	Display Domain Name-Server	Configure
no ip address	Delete IPv4 address	Configure
no ip default-gateway	Clear the default gateway address	Configure
no ip name-server	Clear the domain name-server	Configure

IPv6 GROUP

Command	Explanation	Mode
ipv6 address add [IPV6_ADDR</PREFIX_LEN>]	Add an address and netmask of IPv6	Configure
ipv6 enable	Enable IPv6 protocol	Configure
ipv6 neighbor flush	Issue a neighbor flush command of IPv6	Configure
ipv6 ping [IPV6_ADDR] [<size PKG_SIZ> <repeat PKG_CNT>]	Issue an IPv6 ping command	Configure
show ipv6	Display IPv6 protocol state	Configure
show ipv6 address	Display IPv6 addresses	Configure
show ipv6 default address	Display default IPv6 address	Configure
show ipv6 neighbor	Display neighbor cache of IPv6	Configure
no ipv6	Disable IPv6 protocol	Configure
no ipv6 address add [IPV6_ADDR/PREFIX_LEN]	Delete IPv6 address	Configure

TIME GROUP

Command	Explanation	Mode
clock time [hh:mm:ss] [day] [month] [year]	Configure time	Configure
clock timezone [AREA] [CITY]	Configure time zone	Configure
ntp client sync [minute hour day month year] [NUMBER]	Configure NTP client sync	Configure
ntp client timeserver1 [SERVER_IP/URL]	Configure NTP client time server 1	Configure
ntp client timeserver2 [SERVER_IP/URL]	Configure NTP client time server 2	Configure
ntp time update	Configure NTP time update	Configure
show clock time	Show time	Configure
show clock timezone	Show timezone	Configure
show ntp client sync	Show sync time	Configure
show ntp client timeserver1	Show NTP server 1 configuration	Configure
show ntp client timeserver2	Show NTP server 2 configuration	Configure
no clock timezone	Remove timezone	Configure
no ntp client sync	Remove NTP sync time	Configure
no ntp client timeserver1	Remove NTP time server 1 configuration	Configure
no ntp client timeserver2	Remove NTP time server 2 configuration	Configure

PTP GROUP

Command	Explanation	Mode
ptp announce interval [-1 to 7]	Set PTP announce interval, the interval is expressed as log 2 . i.e. -1 is 0.5s, 0 is 1s.	Configure
ptp announce timeout [2-255]	Set PTP announce timeout	Configure
ptp disable	Disable PTP	Configure
ptp domain [0-127]	Set PTP domain number	Configure
ptp enable	Enable PTP	Configure
ptp mode [m(master) s(slave)]	Set PTP mode	
ptp period [0-20]	Set PTP timeout periods	Configure
ptp priority1 [0-248]	Set PTP priority1	Configure
ptp priority2 [0-248]	Set PTP priority2	Configure
ptp sync interval [-7 to 7]	Set PTP sync interval, the interval is expressed as log 2 . i.e. -1 is 0.5s, 0 is 1s.	Configure
show ptp announce interval	Display PTP announce interval	Configure
show ptp announce timeout	Display PTP announce timeout	Configure
show ptp clock	Display PTP sync information	Configure
show ptp domain	Display PTP domain number	Configure
show ptp enable	Display PTP status	Configure
show ptp mode	Display PTP mode	Configure
show ptp period	Display PTP timeout periods	Configure
show ptp priority1	Display PTP priority1	Configure
show ptp priority2	Display PTP priority2	Configure
show ptp sync interval	Display PTP sync interval	Configure
no ptp announce interval	Default PTP announce interval	Configure
no ptp announce timeout	Default PTP announce timeout	Configure
no ptp domain	Default PTP domain number	Configure
no ptp mode	Default PTP mode	Configure
no ptp period	Default PTP timeout periods	Configure
no ptp priority1	Default PTP priority1	Configure
no ptp priority2	Default PTP priority2	Configure
no ptp sync interval	Default PTP sync interval	Configure

STP GROUP

Command	Explanation	Mode
spanning-tree forward-time [4-30]	Set STP forward time	Configure
spanning-tree hello-time [1-10]	Set STP hello time	Configure
spanning-tree max-age [6-40]	Set max age	Configure
spanning-tree mode [rstp]	Set STP mode as [RSTP]	Configure

spanning-tree mst instance [1-15] vlan [VLAN_LIST]	Set vlan group for specific MSTP instance	Configure
spanning-tree mst name [NAME]	Set MSTP name	Configure
spanning-tree mst revision [0-65535]	Set MSTP revision	Configure
spanning-tree mst [1-15] priority [0-61440]	Set priority for specific MSTP instance	Configure
spanning-tree priority [0-61440]	Set STP priority	Configure
spanning-tree cost [0-200000000]	Configure STP cost	Interface
spanning-tree edge [admin-edge admin-non-edge]	Configure STP edge	Interface
spanning-tree link-type [point-to-multiple point-to-point]	Configure STP link type on port	Interface
spanning-tree mst [1-15] cost [0-200000000]	Configure port cost for specific MSTP instance	Interface
spanning-tree mst [1-15] port-priority [0-200000000]	Configure port priority for specific MSTP instance	Interface
spanning-tree port-priority [0-240]	Configure STP port priority	Interface
spanning-tree stp disable	Disable Spanning Tree Protocol (STP) on port	Interface
show spanning-tree forward-time	Show STP forward time	Configure
show spanning-tree hello-time	Show STP hello time	Configure
show spanning-tree max-age	Show STP max age	Configure
show spanning-tree mode	Show Spanning Tree mode (RSTP or disable)	Configure
show spanning-tree mst instance [1-15] vlan	Show vlan group for specific MSTP instance	Configure
show spanning-tree mst name	Show MSTP name	Configure
show spanning-tree mst revision	Show MSTP revision	Configure
show spanning-tree mst [1-15] priority	Show priority for specific MSTP instance	Configure
show spanning-tree mst [1-15] status	Show bridge status for specific MSTP instance	Configure
show spanning-tree priority	Show STP priority	Configure
show spanning-tree rstp-status	Show Spanning Tree rstp status	Configure
show spanning-tree cost	Show STP cost	Interface
show spanning-tree edge	Show STP auto edge	Interface
show spanning-tree link-type	Show STP link type	Interface
show spanning-tree mst [1-15] cost	Show port cost for specific MSTP instance	Interface
show spanning-tree mst [1-15] port-priority	Show port priority for specific MSTP instance	Interface
show spanning-tree port-priority	Show STP port priority	Interface
show spanning-tree stp	Show STP activated status on port	Interface
no spanning-tree forward-time	Remove STP forward time configuration	Configure
no spanning-tree hello-time	Remove STP hello time configuration	Configure
no spanning-tree max-age	Remove STP max age configuration	Configure
no spanning-tree mode	Disable STP configuration	Configure
no spanning-tree priority	Remove STP priority configuration	Configure

no spanning-tree cost	Remove STP cost configuration	Interface
no spanning-tree edge	Remove auto edge configuration	Interface
no spanning-tree link-type	Remove link type configuration	Interface
no spanning-tree mst [1-15] cost	Remove port cost for specific MSTP instance	Interface
no spanning-tree mst [1-15] port-priority	Remove port priority for specific MSTP instance	Interface
no spanning-tree port-priority	Remove STP port priority configuration	Interface
no spanning-tree stp	Enable STP on port	Interface

ERPS GROUP

Command	Explanation	Mode
ethernet redundancy erps-ring [1 2 3]	Ethernet Ring Protection Switching (ERPS) mode	Configure
aps-channel [1 - 4094]	Set APS channel	ERPS
disable	Disable ERPS function	ERPS
enable	Enable ERPS function	ERPS
erps-ring [1 2 3]	Change to Other ERPS Ring	ERPS
ext-command clear	Extended ERPS command - Clear	ERPS
ext-command fs	Extended ERPS command – Forced Switch	ERPS
ext-command ms	Extended ERPS command – Manual Switch	ERPS
id [1 - 239]	Set Ring ID	ERPS
mel [0 - 7]	ERPS mel	ERPS
revertive	Set as revertive mode	ERPS
ring-port 0 [1(lan1) - N(lanN)]	Mapping ERPS ring port0 to switch port	ERPS
ring-port 1 [1(lan1) - N(lanN)]	Mapping ERPS ring port1 to switch port	ERPS
role port0 [o(owner) n(neigh) i(interconn)]	Set role on ring port0	ERPS
role port1 [o(owner) n(neigh) i(interconn)]	Set role on ring port1	ERPS
timer guard [10 - 2000]	Set guard timer interval	ERPS
timer hold-off [0 - 10000]	Set hold-off timer interval	ERPS
timer wtr [1 - 12]	Set WTR timer interval	ERPS
type [m(major-ring) s(sub-ring)]	Set type as Major-Ring or Sub-Ring	ERPS
virtual-channel major-ring channel-id [1-4094]	Set virtual channel for ERPS Ring	ERPS
virtual-channel sub-ring set	Set virtual channel for ERPS Sub-ring	ERPS
show config	Displays ERPS configuration	ERPS
show port status	Displays ERPS ring port status	ERPS
show status	Displays ERPS status	ERPS
no aps-channel	Default ERPS aps-channel	ERPS
no id	Default Ring ID as default	ERPS
no revertive	Default mode non-revertive	ERPS

no ring-port 0	Default ring port0 as lan1	ERPS
no ring-port 1	Default ring port1 as lan2	ERPS
no role port0	Default role of ring port0 as none	ERPS
no role port1	Default role of ring port1 as none	ERPS
no timer guard	Default guard timer	ERPS
no timer hold-off	Default hold-off timer	ERPS
no timer wtr	Default wtr timer	ERPS
no type	Default ring type as Major-Ring	ERPS
no virtual-channel major-ring channel-id	Default virtual channel as ERPS Major Ring's aps-channell	ERPS
no virtual-channel sub-ring set	Default virtual channel for ERPS Sub-ring as None	ERPS

MRP GROUP

Command	Explanation	Mode
ethernet redundancy mrp instance-mode [1]	Media Redundancy Protocol (MRP) mode	Configure
advanced-mode [enable disable]	Enable/Disable MRP Advanced Mode	MRP
domain-id [DOMAIN_ID]	Set MRP Domain-id, the format is 16 bytes in decimal notaion	MRP
name [DOMAIN_NAME]	Set MRP Domain Name	MRP
operation [enable disable]	Enable/Disable MRP Protocol	MRP
port 1 [1(lan1) - N(lanN)]	Set MRP ring-port 1 ID	MRP
port 2 [1(lan1) - N(lanN)]	Set MRP ring-port 2 ID	MRP
recovery-delay [500 200]	Set MRP Recovery Delay (unit: ms)	MRP
role [m(manager) c(client)]	Set MRP Role to MRM(manager) or MRC(client)	MRP
show advanced-mode	Display MRP Advanced-mode	MRP
show config	Display MRP Domain Config	MRP
show domain-id	Display MRP Domain ID	MRP
show name	Display MRP Domain Name	MRP
show operation	Display MRP Operation Status	MRP
show port [1 2]	Display MRP ring-port [1 2] ID	MRP
show recovery-delay	Display MRP Recovery Delay	MRP
show role	Display MRP Domain Expected Role	MRP
show summary	Display MRP Domain Summary	MRP
no domain-id	Default MRP Domain ID	MRP
no name	Clear MRP Domain Name	MRP
no port [1 2]	Default MRP ring-port [1 2] ID	MRP
no recovery-delay	Default MRP Recovery Delay	MRP
no role	Default MRP Domain role	MRP

SNMP GROUP

Command	Explanation	Mode
snmp server community ro [COMMUNITY]	Set v1, v2c snmp server read-only community	Configure
snmp server community rw [COMMUNITY]	Set v1, v2c snmp server read-write community	Configure
snmp server enable	Enable snmp server	Configure
snmp server enable v1-v2c-only	Enable snmp v1 and v2c	Configure
snmp server enable v3-only	Enable snmp v3 command only	Configure
snmp server v3 auth admin [md5 sha] [PASSWORD]	Set SNMPv3 admin authentication type	Configure
snmp server v3 auth user [md5 sha] [PASSWORD]	Set SNMPv3 user authentication type	Configure
snmp server v3 encryption admin [des aes] [PASSWORD]	Set SNMPv3 admin encryption type	Configure
snmp server v3 encryption user [des aes] [PASSWORD]	Set SNMPv3 user encryption type	Configure
snmp server v3 level admin [auth noauth priv]	Set SNMPv3 admin security level	Configure
snmp server v3 level user [auth noauth priv]	Set SNMPv3 user security level	Configure
snmp trap community [COMMUNITY]	Set v1, v2c snmp trap community	Configure
snmp trap host1 [TRAP_HOST_IP]	Set snmp trap host 1 IP address	Configure
snmp trap host2 [TRAP_HOST_IP]	Set snmp trap host 2 IP address	Configure
snmp trap inform retry [1-100]	Set snmp inform retry times	Configure
snmp trap inform timeout [1-300]	Set snmp inform timeout	Configure
snmp trap v3 auth [sha md5] [PASSWORD]	Set SNMPv3 authentication type: md5 or sha	Configure
snmp trap v3 encryption [des aes] [PASSWORD]	Set SNMPv3 encryption type: des or aes	Configure
snmp trap v3 engine-ID [ENGINE_ID]	Set snmp trap engine ID	Configure
snmp trap v3 level [auth noauth priv]	Set SNMPv3 trap security level	Configure
snmp trap v3 user [USER_ID]	Set SNMPv3 trap user	Configure
snmp trap version [1 2c trap 2c inform 3 trap 3 inform]	Set snmp trap version and type	Configure
show snmp server	Display snmp server status	Configure
show snmp server community ro	Display snmp server read only community	Configure
show snmp server community rw	Display snmp server writable community	Configure
show snmp server v3 auth admin	Display SNMPv3 admin authentication type and passphrase	Configure
show snmp server v3 auth user	Display SNMPv3 user authentication type and passphrase	Configure
show snmp server v3 encryption admin	Display SNMPv3 admin encryption type and passphrase	Configure
show snmp server v3 encryption user	Display SNMPv3 user encryption type and passphrase	Configure

show snmp server v3 level admin	Display SNMPv3 admin security level	Configure
show snmp server v3 level user	Display SNMPv3 user security level	Configure
show snmp trap community	Display snmp trap community	Configure
show snmp trap host1	Display snmp trap host 1	Configure
show snmp trap host2	Display snmp trap host 2	Configure
show snmp trap inform retry	Display snmp inform retry times	Configure
show snmp trap inform timeout	Display snmp inform timeout	Configure
show snmp trap v3 auth	Display SNMPv3 authentication type and passphrase	Configure
show snmp trap v3 encryption	Display SNMPv3 encryption type and passphrase	Configure
show snmp trap v3 engine-ID	Display snmp trap engine ID	Configure
show snmp trap v3 level	Display SNMPv3 trap security level	Configure
show snmp trap v3 user	Display SNMPv3 trap user	Configure
show snmp trap version	Display snmp trap version and type	Configure
no snmp server	Disable snmp server	Configure
no snmp server community ro	Default ro-community name	Configure
no snmp server community rw	Default rw-community name	Configure
no snmp server v3 auth admin	Default SNMPv3 admin authentication type	Configure
no snmp server v3 auth user	Default SNMPv3 user authentication type	Configure
no snmp server v3 encryption admin	Default SNMPv3 admin encryption type	Configure
no snmp server v3 encryption user	Default SNMPv3 user encryption type	Configure
no snmp server v3 level admin	Default SNMPv3 admin security level	Configure
no snmp server v3 level user	Default SNMPv3 user security level	Configure
no snmp trap community	Default snmp trap community	Configure
no snmp trap host1	Default snmp trap host 1	Configure
no snmp trap host2	Default snmp trap host 2	Configure
no snmp trap inform retry	Default snmp inform retry times	Configure
no snmp trap inform timeout	Default snmp inform timeout	Configure
no snmp trap v3 auth	Default SNMPv3 authentication type and passphrase	Configure
no snmp trap v3 encryption	Default SNMPv3 encryption type and passphrase	Configure
no snmp trap v3 engine-ID	Default snmp trap engine ID	Configure
no snmp trap v3 level	Default SNMPv3 trap security level	Configure
no snmp trap v3 user	Default SNMPv3 trap user	Configure
no snmp trap version	Default snmp trap version	Configure

DHCP GROUP

Command	Explanation	Mode
boot host dhcp	Directs the system to get an IP address	Configure

dhcp relay information option	Set DHCP-relay option	Configure
dhcp relay server [server_number: 1-4] [server_IP]	Set DHCP-relay server [1-4] IP	Configure
dhcp relay untrust	Set DHCP-relay untrusted port	Interface
dhcp server binding [bind_ID: 1 - 32] [MAC] [IP_TO_BIND]	Set binding IP and MAC of DHCP	Configure
dhcp server default-gateway [IP_ADDR]	Set default-gateway IP for DHCP client	Configure
dhcp server included-address [START_OF_IP] [END_OF_IP]	Set IP range for its client	Configure
dhcp server lease-time [60-2592000]	Set DHCP server lease time	Configure
dhcp server name-server [IP_ADDR]	Set name-server address for DHCP client	Configure
dhcp service relay enable	Enable DHCP relay	Configure
dhcp service server enable	Enable DHCP server	Configure
show boot host dhcp	Display DHCP client state	Configure
show dhcp relay information option	Display DHCP relay option	Configure
show dhcp relay server [server_number: 1-4]	Display DHCP relay address	Configure
show dhcp relay untrust	Display DHCP untrusted port status	Interface
show dhcp server binding	Display all DHCP bounding entries	Configure
show dhcp server default-gateway	Display DHCP default-gateway IP	Configure
show dhcp server included-address	Display DHCP included IP range	Configure
show dhcp server lease	Display DHCP lease entries	Configure
show dhcp server lease-time	Display DHCP server lease time	Configure
show dhcp server name-server	Display DHCP name-server	Configure
show dhcp server status	Display DHCP server status	Configure
show dhcp service relay	Display DHCP relay agent status	Configure
show dhcp service server	Display DHCP server status	Configure
no boot host dhcp	Disable DHCP client	Configure
no dhcp relay information option	Disable DHCP relay option	Configure
no dhcp relay server [server_number: 1-4]	Remove DHCP relay server [1-4] IP	Configure
no dhcp relay untrust	Default port as trusted	Interface
no dhcp server binding [bind_ID: 1-32]	Remove DHCP bounding IP and MAC	Configure
no dhcp server default-gateway	Remove DHCP default-gateway IP	Configure
no dhcp server included-address	Remove DHCP included IP range	Configure
no dhcp server lease-time	Remove DHCP lease time	Configure
no dhcp server name-server	Remove DHCP name-server	Configure
no dhcp service relay	Disable DHCP relay	Configure
no dhcp service server	Disable DHCP server	Configure

INDUSTRIAL PROTOCOLS GROUP

Command	Explanation	Mode
ethernet-ip enable	Enable EtherNet/IP Protocol	Configure
modbus tcp enable	Enable Modbus/TCP Protocol	Configure

profinet enable	Enable PROFINET Protocol	Configure
show ethernet-ip	Show EtherNet/IP status	Configure
show modbus tcp	Show Modbus/TCP status	Configure
show profinet	Show PROFINET status	Configure
no ethernet-ip	Disable EtherNet/IP Protocol	Configure
no modbus tcp	Disable Modbus/TCP Protocol	Configure
no profinet	Disable PROFINET Protocol	Configure

UPNP GROUP

Command	Explanation	Mode
upnp advertisement interval [300-86400]	Set UPnP advertisement interval	Configure
upnp enable	Enable Universal Plug and Play (UPnP)	Configure
show upnp	Display Universal Plug and Play (UPnP) state	Configure
show upnp advertisement interval	Display UPnP advertisement interval	Configure
no upnp	Disable Universal Plug and Play (UPnP)	Configure
no upnp advertisement interval	Default UPnP advertisement interval	Configure

TRDP GROUP

Command	Explanation	Mode
trdp disable	Disable TRDP	Configure
trdp dst-ip [IP_ADDR]	Set TRDP destination IP	Configure
trdp enable	Enable TRDP	Configure
trdp md port [PORT]	Set MD UDP and TCP port	Configure
trdp md protocol [tcp udp]	Set MD protocol	Configure
trdp md role [c(caller) r(replier)]	Set MD role	Configure
trdp md timeout [TIMEOUT(us)]	Set MD reply timeout	Configure
trdp pd cycle [CYCLE TIME(us)]	Set PD cycle	Configure
trdp pd mode [push pull]	Set PD mode	Configure
trdp pd port [PORT]	Set PD UDP port	Configure
trdp pd role [s(subscriber) p(publisher)]	Set PD role	Configure
trdp pd timeout [TIMEOUT(us)]	Set PD timeout	Configure
show trdp dst-ip	Display TRDP destination IP	Configure
show trdp enable	Display Enable TRDP	Configure
show trdp md port	Display MD UDP and TCP port	Configure
show trdp md protocol	Display MD protocol	Configure
show trdp md role	Display MD role	Configure
show trdp md timeout	Display MD reply timeout	Configure
show trdp pd cycle	Display PD cycle	Configure
show trdp pd mode	Display PD mode	Configure
show trdp pd port	Display PD UDP port	Configure

show trdp pd role	Display PD role	Configure
show trdp pd timeout	Display PD timeout	Configure
show trdp status	Display TRDP Status	Configure
no trdp dst-ip	Default TRDP destination IP	Configure
no trdp md port	Default MD UDP and TCP port	Configure
no trdp md protocol	Default MD protocol	Configure
no trdp md role	Default MD role	Configure
no trdp md timeout	Default MD reply timeout	Configure
no trdp pd cycle	Default PD cycle	Configure
no trdp pd mode	Default PD mode	Configure
no trdp pd port	Default PD UDP port	Configure
no trdp pd role	Default PD role	Configure
no trdp pd timeout	Default PD timeout	Configure

PORT GROUP

Command	Explanation	Mode
eee port-enable	802.3az (EEE) port enable	Interface
flowcontrol [on off]	Configure port's flow-control to response a pause frame	Interface
name [PORT_NAME]	Set interface name	Interface
shutdown	Disable port	Interface
speed_duplex [10 100] [full half]	Configure port's speed and duplex	Interface
show interface all link summary	To display interface link status globally	Configure
show administrate	To display port's admin state	Interface
show eee port-all	Display EEE port-all status	Configure
show eee-info	Display Port EEE statistic information	Interface
show flowcontrol	Display port's flow-control state	Interface
show link duplex	To display port's duplex	Interface
show link rx	To display port's Rx_Bytes	Interface
show link speed	To display port's speed	Interface
show link state	To display port's link state	Interface
show link summary	To display port's link summary	Interface
show link tx	To display port's Tx_Bytes	Interface
show name	To display port's name	Interface
show speed_duplex	To display port's speed and duplex	Interface
show transceiver	Transceiver information	Interface
no eee port-enable	802.3az (EEE) port disable	Interface
no flowcontrol	Default flow-control as Auto mode	Interface
no name	Remove port's name	Interface
no shutdown	Enable port	Interface

no speed_duplex	Default port speed-duplex as Auto mode	Interface
-----------------	--	-----------

POE GROUP

Command	Explanation	Mode
power inline budget [1-240]	Power PoE budget	Configure
power inline mode-config disable	Disable PoE on port	Interface
power inline mode-config enable	Enable PoE on port	Interface
power inline mode-config force	Force PoE powered on port	Interface
power inline priority [1-3]	Set PoE port priority on port; 1:high, 2:middle, 3:low	Interface
keepalive enable	Enable PoE keepalive	Interface
keepalive hold-time	Configure PoE keepalive power cycle hold-time	Interface
keepalive ip	Configure IP for PoE keepalive	Interface
keepalive time	Configure PoE keepalive cycle time	Interface
schedule enable	Enable one port PoE schedule	Interface
schedule [Sunday-Saturday] open-time [time]	Configure PoE schedule open time on one day	Interface
show power inline budget	Display PoE power budget	Configure
show power inline detail-code	Display PoE status code, refer to "PoE Debug Code" for more explanation	Interface
show power inline operation	Display All PoE ports operation status	Configure
show power inline status	Display All PoE ports detail status	Configure
show power inline status	Display PoE status for specific port	Interface
show power inline temperature	Display temperature of PoE controller	Configure
show keepalive table	Display All PoE keepalive info	Configure
show power inline status	Display PoE status	Interface
show keepalive	Show PoE keepalive status	Interface
show keepalive hold-time	Show PoE keepalive hold-time	Interface
show keepalive ip	Show IP for PoE keepalive	Interface
show keepalive time	Show PoE keepalive cycle time	Interface
show schedule	Disable Universal Plug and Play (UPnP)	Interface
show schedule [Sunday-Saturday] open-time	Show open time of POE schedule on one day	Interface
show schedule table	Show one port PoE schedule table	Interface
no power inline budget	Default PoE power budget	Configure
no power inline mode-config	Default PoE powered config on port	Interface
no power inline priority	Disable PoE port priority on port	Interface
no keepalive	Disable PoE keepalive	Interface
no keepalive hold-time	Default PoE keepalive power cycle hold-time	Interface
no keepalive ip	Remove IP for PoE keepalive	Interface
no keepalive time	Remove PoE keepalive cycle time	Interface

no schedule		Interface
no schedule [Sunday-Saturday] open-time	Remove PoE schedule on one day	

IGMP SNOOPING GROUP

Command	Explanation	Mode
igmp snooping enable	Enable IGMP snooping	Configure
igmp snooping last-member count [2-10]	Set IGMP last-member-count	Configure
igmp snooping last-member interval [1-25]	Set IGMP last-member-interval	Configure
igmp snooping querier enable	Enable IGMP snooping querier	Configure
igmp snooping query interval [1-3600]	Set IGMP query interval	Configure
igmp snooping query max-respond-time [1-12]	Set IGMP max-query-respond time	Configure
igmp snooping query version [VLAN_ID] [STATE:0 1] [VERSION:1 2 3]	Add IGMP query version entry by VLAN ID. STATE 0: disable; STATE 1: enable	Configure
igmp snooping router-port [PORT_LIST]	Set router port list for multicast	Configure
igmp snooping unknown-multicast [f d r]	Set unknown-multicast action	Configure
show igmp snooping all	Display IGMP settings (summary)	Configure
show igmp snooping mdb	Display IGMP multicast database	Configure
show igmp snooping query-version	Display IGMP Query version by VLAN ID	Configure
show igmp snooping router-port	Display IGMP router port list	Configure
show igmp snooping unknown-multicast	Display unknown-multicast action	Configure
no igmp snooping	Disable IGMP snooping	Configure
no igmp snooping last-member count	Default IGMP Last-Member-Count	Configure
no igmp snooping last-member interval	Default IGMP Last-Member-Interval	Configure
no igmp snooping querier	Disable IGMP querier	Configure
no igmp snooping query interval	Default IGMP query interval	Configure
no igmp snooping query max-respond-time	Default IGMP max-respond-time	Configure
no igmp snooping router-port	Default IGMP router port	Configure
no igmp snooping unknown-multicast	Default unknown-multicast action	Configure

VLAN GROUP

Command	Explanation	Mode
management-vlan [VLAN_ID: 1-4094]	Configure management vlan ID	Configure
provider ethertype [VALUE_IN_HEX (i.e., 0x88A8)]	Setup EtherType in S-TAG for provider port	Configure
member [untag PORT_LIST] [tag PORT_LIST]	Set VLAN member	VLAN
name [VLAN_NAME]	Set VLAN Name	VLAN
switchport accept [tagged untagged]	Set VLAN acceptance of frame	Interface
switchport mode [d(dot1q-tunnel) c(customer) p(provider) s(specific-provider)]	Configure port type as dot1q-tunnel, Customer, or Service Provider	Interface
switchport pvid [PVID: 1-4094]	Set port VLAN-Id	Interface

show management-vlan	Display management vlan ID	Configure
show provider ethertype	Display Service Provider EtherType	Configure
show vlan global	Display VLAN Global information	Configure
show member	Display port VLAN member	VLAN
show name	Display VLAN name	VLAN
show switchport accept	Display acceptance of VLAN frame	Interface
show switchport mode	Display VLAN interface port type	Interface
show switchport pvid	Display port VLAN-Id	Interface
no management-vlan	Set management vlan to default	Configure
no provider ethertype	Default EtherType as 0x88A8 in S-TAG for provider port	Configure
no member	Default VLAN member	VLAN
no name	Default VLAN name	VLAN
no switchport accept	Default acceptance of VLAN frame	Interface
no switchport mode	Default port type as Customer	Interface
no switchport pvid	Default port VLAN-Id	Interface

QoS GROUP

Command	Explanation	Mode
qos fair-queue weight [W0] [W1] [W2] [W3] [W4] [W5] [W6] [W7]	Set WRR Queue Weight	Configure
qos map cos [priority:0-7] to tx-queue [0-7]	Set Cos queue mapping of priority [0-7]	Configure
qos map dscp [0-63] to tx-queue [0-7]	Set DSCP mapping queue	Configure
qos queue-schedule [strict wrr]	Set QoS scheduling type	Configure
qos default cos [0-7]	Set Default Class of Service (COS) value	Interface
qos trust [cos dscp]	Set trust of cos or dscp	Interface
show qos fair-queue weight	Display WRR Queue Weight	Configure
show qos map cos	Display global QoS queue mapping status	Configure
show qos map cos [0-7]	Display QoS queue mapping status of Priority [0-7]	Configure
show qos map dscp	Display global DSCP queue mapping status	Configure
show qos map dscp [0-63]	Display DSCP queue mapping status of class [0-63]	Configure
show qos queue-schedule	Display queue scheduling type	Configure
show qos default cos	Display CoS default value	Interface
show qos trust	Display QoS trust	Interface
no qos fair-queue weight	Default WRR Queue Weight	Configure
no qos map cos [0-7]	Reset Cos queue mapping of priority [0-7]	Configure
no qos map dscp [0-63]	Reset DSCP mapping queue to default	Configure
no qos queue-schedule	Default scheduling type as WRR	Configure
no qos default cos	Reset default CoS to initial value	Interface

no qos trust	Default trust as CoS	Interface
--------------	----------------------	-----------

PORT TRUNK GROUP

Command	Explanation	Mode
trunk group [1-8] [static lacp] INTERFACES_LIST	Configure port aggregation group	Configure
show trunk group	Show all trunk groups	Configure
show trunk group [1-8]	Show trunk group [1-8]	Configure
no trunk group [1-8]	Remove trunk group [1-8]	Configure

STORM CONTROL GROUP

Command	Explanation	Mode
storm-control broadcast enable	Enable the broadcast storm control	Configure
storm-control broadcast level [low mid high]	Set the broadcast storm control level	Configure
storm-control multicast enable	Enable the multicast storm control	Configure
storm-control multicast level [low mid high]	Set the multicast storm control level	Configure
storm-control unknown-unicast enable	Enable the unknown-unicast storm control	Configure
storm-control unknown-unicast level [low mid high]	Set the unknown-unicast storm control level	Configure
show storm-control broadcast	Display the broadcast storm control status	Configure
show storm-control broadcast level	Display the broadcast storm control level	Configure
show storm-control multicast	Display the multicast storm control status	Configure
show storm-control multicast level	Display the multicast storm control level	Configure
show storm-control unknown-unicast	Display the unknown-unicast storm control status	Configure
show storm-control unknown-unicast level	Display the unknown-unicast storm control level	Configure
no storm-control broadcast	Disable the broadcast storm control	Configure
no storm-control broadcast level	Default the broadcast storm control to level high	Configure
no storm-control multicast	Disable the multicast storm control	Configure
no storm-control multicast level	Default the multicast storm control to level high	Configure
no storm-control unknown-unicast	Disable the unknown-unicast storm control	Configure
no storm-control unknown-unicast level	Default the unknown-unicast storm control to level high	Configure

802.1X GROUP

Command	Explanation	Mode
---------	-------------	------

dot1x authentication server [1 2] ip [IP]	Set 802.1X authentication server 1 or 2 address	Configure
dot1x authentication server [1 2] port [PORT]	Set 802.1X authentication server 1 or 2 port	Configure
dot1x authentication server [1 2] share-key [KEY]	Set 802.1X authentication server 1 or 2 share-key	Configure
dot1x authentication server type [local radius]	Set 802.1X authentication server type	Configure
dot1x enable	Enable 802.1X protocol	Configure
dot1x local-db [USER] [PASSWORD]	Set 802.1X local user database	Configure
dot1x authenticator enable	Set 802.1X authenticator	Interface
dot1x mode [mac-based port-based]	Set 802.1X mode as 1. MAC-based, 2.Port-based	Interface
dot1x reauthentication enable	Set 802.1X reauthentication	Interface
dot1x reauthentication period [60-65535]	Set 802.1X reauthentication period	Interface
show dot1x	Display 802.1X protocol state	Configure
show dot1x authentication server [1 2] ip	Display 802.1X authentication server 1 or 2 address	Configure
show dot1x authentication server [1 2] port	Display 802.1X authentication server 1 or 2 port	Configure
show dot1x authentication server [1 2] share-key	Display 802.1X authentication server 1 or 2 key	Configure
show dot1x authentication server type	Display 802.1X authentication server type	Configure
show dot1x brief	Display 802.1X information	Configure
show dot1x local-db	Display 802.1X users and password in database	Configure
show dot1x server brief	Display 802.1X RADIUS server	Configure
show dot1x authenticator	Display 802.1X authenticator state	Interface
show dot1x mode	Display 802.1X mode config	Interface
show dot1x reauthentication	Display 802.1X reauthentication state	Interface
show dot1x reauthentication period	Display 802.1X reauthentication period (in sec.)	Interface
no dot1x	Disable 802.1X protocol	Configure
no dot1x authentication server [1 2] ip	Default 802.1X authentication server 1 or 2 address	Configure
no dot1x authentication server [1 2] port	Default 802.1X authentication server 1 or 2 port	Configure
no dot1x authentication server [1 2] share-key	Default 802.1X authentication server 1 or 2 share-key	Configure
no dot1x authentication server type	Default 802.1X authentication server type	Configure
no dot1x local-db [USER]	Remove an entry in 802.1X local database	Configure
no dot1x authenticator	Disable 802.1X authenticator	Interface
no dot1x mode	Default 802.1X mode as MAC-based	Interface
no dot1x reauthentication	Disable 802.1X reauthentication	Interface
no dot1x reauthentication period	Default 802.1X reauthentication period	Interface

PORT MIRROR GROUP

Command	Explanation	Mode
mirror destination [DEST_PORT]	Set mirror interface of destination	Configure
mirror enable	Enable port mirror	Configure
mirror source [rx tx both] [PORT_LIST]	Set mirror interface of source	Configure
show mirror	Show port mirror enable/disable state	Configure
show mirror destination	Show port mirror destination configuration	Configure
show mirror source	Show port mirror source configuration	Configure
no mirror	Disable port mirror	Configure
no mirror destination	Delete port mirror Destination configuration	Configure
no mirror source	Delete port mirror Source configuration	Configure

REMOTE SPAN GROUP

Command	Explanation	Mode
rspan destination [DEST_PORT]	Set remote SPAN interface of destination	Configure
rspan mode source enable	Enable remote SPAN of source	Configure
rspan mode destination enable	Enable remote SPAN of destination	Configure
rspan reflector [REFLECTOR_PORT]	Set remote SPAN interface of reflector	Configure
rspan source [rx tx] [PORT]	Set remote SPAN monitor traffic and interface of source	Configure
rspan vlan-id [2 - 1001, 1006 - 4094]	Set remote SPAN VLAN-Id	Configure
show rspan	Show remote SPAN enable/disable state	Configure
show rspan destination	Show remote SPAN destination configuration	Configure
show rspan reflector	Show remote SPAN reflector configuration	Configure
show rspan source	Show remote SPAN source configuration	Configure
show rspan vlan-id	Show remote SPAN VLAN-Id configuration	Configure
no rspan	Disable remote SPAN	Configure
no rspan destination	Delete remote SPAN destination configuration	Configure
no rspan reflector	Delete remote SPAN reflector configuration	Configure
no rspan source	Delete remote SPAN source configuration	Configure
no rspan vlan-id	Delete remote SPAN VLAN-Id configuration	Configure

LLDP GROUP

Command	Explanation	Mode
lldp enable	Enable LLDP protocol	Configure
lldp timer [5-32767]	Set LLDP timer	Configure
show lldp neighbor	Display LLDP neighbor	Configure
show lldp neighbor detail	Display LLDP neighbors in detail	Configure
show lldp state	Display LLDP status	Configure

show lldp timer	Display LLDP timer	Configure
no lldp	Disable LLDP protocol	Configure
no lldp timer	Default LLDP timer	Configure

SYSLOG GROUP

Command	Explanation	Mode
syslog local enable	Enable logging to local	Configure
syslog log clear	Clear syslog log	Configure
syslog remote enable	Enable logging to remote	Configure
syslog remote port [PORT]	Set syslog remote server port	Configure
syslog remote server [ADDRESS]	Set syslog remote server address	Configure
syslog usb enable	Enable log to USB device	Configure
show syslog local	Display local logging state	Configure
show syslog log	Display syslog messages	Configure
show syslog remote	Display remote logging state	Configure
show syslog remote port	Display remote server port	Configure
show syslog remote server	Display remote server IP	Configure
show syslog usb	Display USB logging state	Configure
no syslog local	Disable logging to local	Configure
no syslog remote	Disable logging to remote	Configure
no syslog remote port	Default syslog remote server port	Configure
no syslog remote server	Clear syslog remote server address	Configure
no syslog usb	Disable logging to USB	Configure

SMTP GROUP

Command	Explanation	Mode
smtp authentication enable	Enable SMTP authentication	Configure
smtp authentication password [PASSWORD]	Set SMTP password	Configure
smtp authentication username [USER_NAME]	Set SMTP username	Configure
smtp enable	Enable SMTP	Configure
smtp receive [1-4] [RECEIVER_ADDRESS]	Set SMTP receiver [1-4] address	Configure
smtp sender [SMTP_SENDER_ADDRESS]	Set SMTP sender	Configure
smtp server address [SMTP_SERVER_ADDRESS]	Set SMTP server address	Configure
smtp server port [SMTP_SERVER_PORT]	Set SMTP server port	Configure
smtp subject [SUBJECT]	Set SMTP subject	Configure
show smtp authentication state	Display SMTP authentication status	Configure
show smtp authentication username	Display SMTP user name	Configure
show smtp receive [1-4]	Display SMTP receiver [1-4]	Configure
show smtp sender	Display SMTP sender	Configure
show smtp server address	Display SMTP server address	Configure

show smtp server port	Display SMTP server port	Configure
show smtp state	Display SMTP service	Configure
show smtp subject	Display SMTP subject	Configure
no smtp authentication	Disable SMTP authentication	Configure
no smtp authentication password	Clear SMTP password	Configure
no smtp authentication username	Clear SMTP user name	Configure
no smtp	Disable SMTP	Configure
no smtp receive [1-4]	Clear SMTP receiver [1-4]	Configure
no smtp sender	Clear SMTP sender	Configure
no smtp server address	Clear SMTP server	Configure
no smtp server port	Clear SMTP server port	Configure
no smtp subject	Clear SMTP subject	Configure

EVENT GROUP

Command	Explanation	Mode
event alarm ddm [lanX-lanY] [current rx_power temperature tx_power voltage]	Register a DDM event of current, Rx power, temperature, Tx power, or voltage	Configure
event alarm digital-input [high low]	Register an event of digital-input	Configure
event alarm interface [lan1-lanN] down	Register an event of Interface DOWN	Configure
event alarm [power1 power2]	Register an event of power 1 or 2 failure	Configure
event smtp auth-failure	Register an event of authentication failure	Configure
event smtp cold-start	Register an event of cold-start	Configure
event smtp ddm [lanX-lanY] [current rx_power temperature tx_power voltage]	Register a DDM event of current, Rx power, temperature, Tx power, or voltage	Configure
event smtp digital-input [high low]	Register an event of digital-input	Configure
event smtp interface [lan1-lanN] down	Register an event of Interface DOWN	Configure
event smtp interface [lan1-lanN] up	Register an event of Interface UP	Configure
event smtp [power1 power2]	Register an event of power 1 or 2 failure	Configure
event smtp warm-start	Register an event of warm-start	Configure
event snmptrap auth-failure	Register an event of authentication failure	Configure
event snmptrap cold-start	Register an event of cold-start	Configure
event snmptrap ddm [lanX-lanY] [current rx_power temperature tx_power voltage]	Register a DDM event of current, Rx power, temperature, Tx power, or voltage	Configure
event snmptrap digital-input [high low]	Register an event of digital-input	Configure
event snmptrap interface [lan1-lanN] down	Register an event of Interface DOWN	Configure
event snmptrap interface [lan1-lanN] up	Register an event of Interface UP	Configure
event snmptrap [power1 power2]	Register an event of power 1 or 2 failure	Configure
event snmptrap warm-start	Register an event of warm-start	Configure
event syslog auth-failure	Register an event of authentication failure	Configure

event syslog cold-start	Register an event of cold-start	Configure
event syslog ddm [lanX-lanY] [current rx_power temperature tx_power voltage]	Register a DDM event of current, Rx power, temperature, Tx power, or voltage	Configure
event syslog digital-input [high low]	Register an event of digital-input	Configure
event syslog interface [lan1-lanN] down	Register an event of Interface DOWN	Configure
event syslog interface [lan1-lanN] up	Register an event of Interface UP	Configure
event syslog [power1 power2]	Register an event of power 1 or 2 failure	Configure
event syslog warm-start	Register an event of warm-start	Configure
show event alarm ddm [lanX-lanY] [current rx_power temperature tx_power voltage]	Display current, Rx power, temperature, Tx power, or voltage event registration	Configure
show event alarm digital-input	Display digital-input event registration	Configure
show event alarm interface [lan1-lanN] down	Display interface DOWN event registration	Configure
show event alarm [power1 power2]	Display power 1 or 2 event registration	Configure
show event smtp auth-failure	Display authentication failure event registration	Configure
show event smtp cold-start	Display cold-start event registration	Configure
show event smtp ddm [lanX-lanY] [current rx_power temperature tx_power voltage]	Display current, Rx power, temperature, Tx power, or voltage event registration	Configure
show event smtp digital-input	Display digital-input event registration	Configure
show event smtp interface [lan1-lanN] down	Display interface DOWN event registration	Configure
show event smtp interface [lan1-lanN] up	Display interface UP event registration	Configure
show event smtp [power1 power2]	Display power 1 or 2 event registration	Configure
show event smtp warm-start	Display warm-start event registration	Configure
show event snmptrap auth-failure	Display authentication failure event registration	Configure
show event snmptrap cold-start	Display cold-start event registration	Configure
show event snmptrap ddm [lanX-lanY] [current rx_power temperature tx_power voltage]	Display current, Rx power, temperature, Tx power, or voltage event registration	Configure
show event snmptrap digital-input	Display digital-input event registration	Configure
show event snmptrap interface [lan1-lanN] down	Display interface DOWN event registration	Configure
show event snmptrap interface [lan1-lanN] up	Display interface UP event registration	Configure
show event snmptrap [power1 power2]	Display power 1 or 2 event registration	Configure
show event snmptrap warm-start	Display warm-start event registration	Configure
show event syslog auth-failure	Display authentication failure event registration	Configure
show event syslog cold-start	Display cold-start event registration	Configure
show event syslog ddm [lanX-lanY] [current rx_power temperature tx_power voltage]	Display current, Rx power, temperature, Tx power, or voltage event registration	Configure

show event syslog digital-input	Display digital-input event registration	Configure
show event syslog interface [lan1-lanN] down	Display interface DOWN event registration	Configure
show event syslog interface [lan1-lanN] up	Display interface UP event registration	Configure
show event syslog [power1 power2]	Display power 1 or 2 event registration	Configure
show event syslog warm-start	Display warm-start event registration	Configure
no event alarm ddm [lanX-lanY] [current rx_power temperature tx_power voltage]	Unregister a DDM event of current, Rx power, temperature, Tx power, or voltage	Configure
no event alarm digital-input	Unregister an event of digital-input	Configure
no event alarm interface [lan1-lanN] down	Unregister an event of Interface DOWN	Configure
no event alarm [power1 power2]	Unregister an event of power 1 or 2 failure	Configure
no event smtp auth-failure	Unregister an event of authentication failure	Configure
no event smtp cold-start	Unregister an event of cold-start	Configure
no event smtp ddm [lanX-lanY] [current rx_power temperature tx_power voltage]	Unregister a DDM event of current, Rx power, temperature, Tx power, or voltage	Configure
no event smtp digital-input	Unregister an event of digital-input	Configure
no event smtp interface [lan1-lanN] down	Unregister an event of Interface DOWN	Configure
no event smtp interface [lan1-lanN] up	Unregister an event of Interface UP	Configure
no event smtp [power1 power2]	Unregister an event of power 1 or 2 failure	Configure
no event smtp warm-start	Unregister an event of warm-start	Configure
no event snmptrap auth-failure	Unregister an event of authentication failure	Configure
no event snmptrap cold-start	Unregister an event of cold-start	Configure
no event snmptrap ddm [lanX-lanY] [current rx_power temperature tx_power voltage]	Unregister a DDM event of current, Rx power, temperature, Tx power, or voltage	Configure
no event snmptrap digital-input	Unregister an event of digital-input	Configure
no event snmptrap interface [lan1-lanN] down	Unregister an event of Interface DOWN	Configure
no event snmptrap interface [lan1-lanN] up	Unregister an event of Interface UP	Configure
no event snmptrap [power1 power2]	Unregister an event of power 1 or 2 failure	Configure
no event snmptrap warm-start	Unregister an event of warm-start	Configure
no event syslog auth-failure	Unregister an event of authentication failure	Configure
no event syslog cold-start	Unregister an event of cold-start	Configure
no event syslog ddm [lanX-lanY] [current rx_power temperature tx_power voltage]	Unregister a DDM event of current, Rx power, temperature, Tx power, or voltage	Configure
no event syslog digital-input	Unregister an event of digital-input	Configure
no event syslog interface [lan1-lanN] down	Unregister an event of Interface DOWN	Configure

no event syslog interface [lan1-lanN] up	Unregister an event of Interface UP	Configure
no event syslog [power1 power2]	Unregister an event of power 1 or 2 failure	Configure
no event syslog warm-start	Unregister an event of warm-start	Configure

MAC ADDRESS TABLE GROUP

Command	Explanation	Mode
clear mac address-table dynamic	Flush dynamic MAC addresses in MAC table	Configure
mac address add [VID: 1-4094] [MAC_ADDR] [PORT]	Set a MAC address to MAC table	Configure
show mac address	Display MAC table	Configure
no mac address [VID: 1-4094] [MAC_ADDR]	Remove a MAC address from FDB	Configure

USB GROUP

Command	Explanation	Mode
usb auto-backup	Auto save to USB if running config is changed	Configure
usb auto-load	Auto load config from USB to switch	Configure
show usb auto-backup	Display USB auto backup activated status	Configure
show usb auto-load	Display USB auto load activated status	Configure
no usb auto-backup	Disable auto save	Configure
no usb auto-load	Disable auto load	Configure

FILE GROUP

Command	Explanation	Mode
copy running-config startup-config	Save running-config to startup-config	Configure
copy running-config usb [file]	Save running-config to USB	Configure
copy startup-config running-config	Restore from startup-config	Configure
copy usb firmware [file]	Upgrade firmware from USB	Configure
copy startup-config usb [file]	Save startup-config to USB	Configure
copy usb startup-config [file]	Restore startup-config from USB	Configure
copy sftp startup-config	Restore startup-config from SFTP server	Configure
copy tftp startup-config	Restore startup-config from TFTP server	Configure
sftp name [FILE_NAME]	Set uploading file name	Configure
upload server ip [SERVER_IP]	Set uploading server IP	Configure
upload tftp	Upload and update firmware via TFTP (slower)	Configure
upload wget	Upload and update firmware via HTTP (faster)	Configure
show upload file name	Display uploading file name	Configure
show upload server ip	Display uploading server IP	Configure
no upload file name	Default uploading file name	Configure

no upload server ip	Clear uploading server IP	Configure
---------------------	---------------------------	-----------

COMMAND & CONTROL NODE (CCN) GROUP

Command	Explanation	Mode
ccn firmware-name [IMAGE_NAME]	Set firmware image name	Configure
ccn probe	Probe CCN-capable hosts in LAN	Configure
ccn upgrade	Upgrade CCN-capable hosts in LAN	Configure
ccn upgrade exclude [INDEX_LIST]	Upgrade CCN-capable hosts except the specified	Configure
ccn upgrade include [INDEX_LIST]	Specify specific CCN-capable hosts to upgrade	Configure
show ccn firmware-name	Display firmware image name	Configure
show ccn hosts	Display CCN-capable hosts	Configure
show ccn probe	Display probing status	Configure
no ccn firmware-name	Delete firmware image name	Configure
no ccn probe	Stop probing CCN-capable hosts in LAN	Configure

Overview

This user manual /datasheet is for CNGE20FX4TX16MSP. This is an industrial managed gigabit PoE+ Ethernet switch with the following hardware features:

Interface

- MDI/MDI-X function supported on all copper ports
- Embedded 16x Gigabit Ethernet ports with 30W PSE + 4x 1000 SFP Slot
- Store-and-forward switching architecture

Switch Properties

- Up to 16K MAC Address Table supported
- Up to 9216bytes Jumbo Frame supported
- Up to 12Mbits Packet Buffer supported

Power Input

- Redundant 48-57VDC power

Temperature

- Standard operating temperature: -40°C ~ 75°C
- Storage temperature: -40°C ~ 85°C (-40°F ~ 185°F)

Mechanical Construction

- Class IP30 protection
- DIN-Rail Mounting, Optional Wall Mounting

PACKAGE CHECK LIST

The "CNGE20FX4TX16MSP" is shipped with the following items. Ensure that all the items are in the box. If any item is missing or damaged, contact us for assistance.

- CNGE20FX4TX16MSP switch x 1
- Protective caps for 16x copper ports, 4x SFP slots, 1x USB port, and 1x RJ45 console port
- RJ45 to RS232 Serial console cable x 1

Hardware Description

FRONT PANEL INSTRUCTION

The following picture is the front panel for "CNGE20FX4TX16MSP".

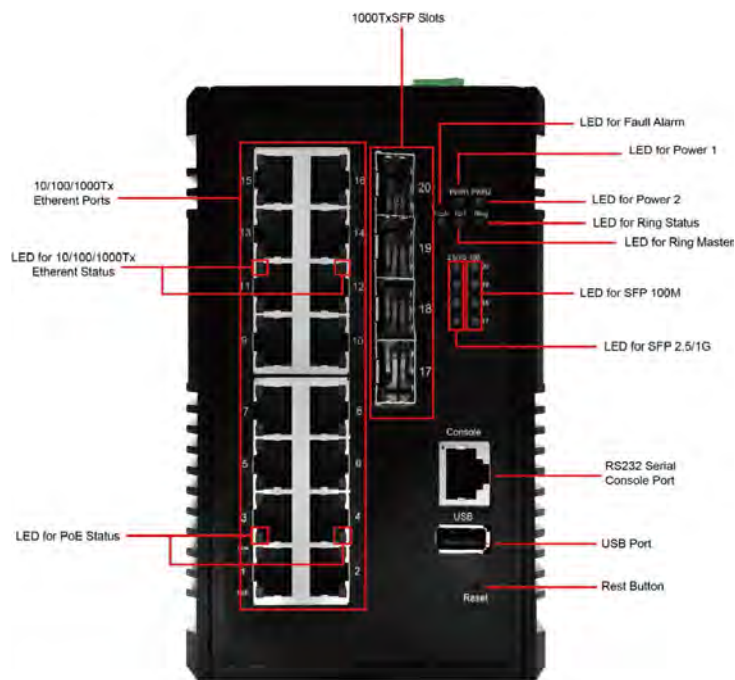

DIMENSIONS

WxHxD: 91x145x118 mm

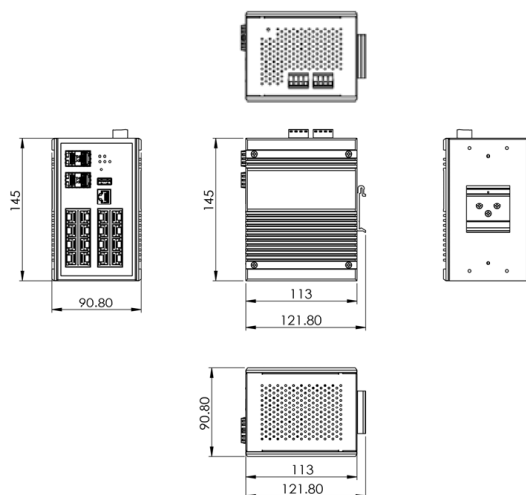

TOP VIEW



This is the top view of the CNGE20FX4TX16MSP containing the ground, power inputs, and fault alarm relay.

LED INSTRUCTION

System LEDs

LED	Color	Status	Description
PWR1	Green	On	Power is supplied on the power input 1.
		Off	Power is not supplied on the power input 1.
PWR2	Green	On	Power is supplied on the power input 2.

		Off	Power is not supplied on the power input 2.
Fault	Green	On	The system boots up and in normal operation.
		Off	The system is powered off or during booting.
	Red	On	The configured event of failure is triggered.
RM	Green	On	This device has the Ring Master.
		Off	The Ring Master is not on the device.
Ring	Green	On	The Ring protocol is enabled and works normally.
		Flashing	The Ring protocol is enabled, but works abnormally.
		Off	The Ring protocol is disabled.

Interface Status LEDs

LED	Color	Status	Description
SFP Slot P17 to P20 (2.5G/1G)	Green	On	The 2.5G/1Gbps link of the fiber port is active.
		Flashing	Data is transmitted on the fiber port at 2.5G/1G bps.
		Off	The 2.5G/1G bps link of the fiber port is inactive.
SFP Slot P17 to P20 (100M)	Amber	On	The 100Mbps link of the fiber port is active.
		Flashing	Data is transmitted on the fiber port at 100Mbps.
		Off	The 100Mbps link of the fiber port is inactive.
LAN Port P1 to P16 (10/100/1000M)	Green	On	The 10/100/1000Mbps link of the port is active.
		Flashing	Data is transmitted on the port at 10/100/1000Mbps.
		Off	The 10/100/1000Mbps link of the port is inactive.
LAN Port P1 to P16 PoE+	Amber	On	An IEEE 802.3at/af powered device is connected.
		Flashing	PoE overload or power budget exceeded.
		Off	No IEEE 802.3at/af powered device is connected.

RESET BUTTON

A multifunctional reset button is provided. Use a pointed object such as toothpick or paper clip (straightened) to press the reset button.

Continuous Seconds	Action
1	Save the running configuration to the USB device named "running-config".
4	Reboot the system.
More than 7	Reset the system to factory default and reboot it.

USB PORT

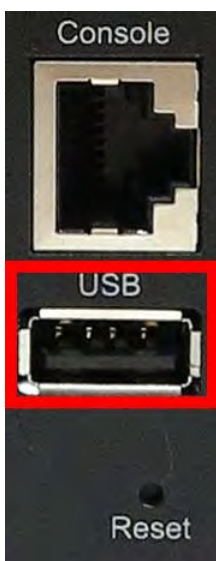

A USB port is available on the switch that is located between the Console port and Reset button. This USB port provides the following features:

- Backup/Restore Configurations
- Auto-Load configuration from USB
- Auto-Backup configuration to USB
- Save system logs to USB

EARTH GROUNDING

The earth grounding and cautious wire routing are helpful to suppress the effects of noise from electromagnetic interference (EMI). The switch has to be installed on a well-grounded surface, for instance, a metal panel.

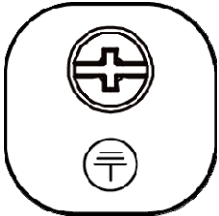

The location of earth ground screw is usually near the location of power inputs, for example:

- Top side for most of din-rail models
- Rear side for most of rack-mount models
- Front side for most of M12 models

Note: Connect the ground from the ground screw to the surface of ground before wiring the power inputs.

Hardware Installation

SFP CABLING

There are 4x 1000 SFP Slot SFP Slots on the "CNGE20FX4TX16MSP" switch. The 100Tx SFP module is not supported in this model.

Insert SFP Module

1. Insert the SFP module. A triangle is available on the switch and SFP module.



2. Push the SFP module down.



Remove SFP Module

1. Press and remove the SFP cable.



2. Open the SFP module and remove it.



WIRING POWER INPUTS



1. Insert the positive and negative wires into the PWR1 (+,-) and PWR2 (+,-) on the 4-contact terminal block connector.
2. Tighten the screws to prevent the wires from loosening.

WIRING FAULT ALARM

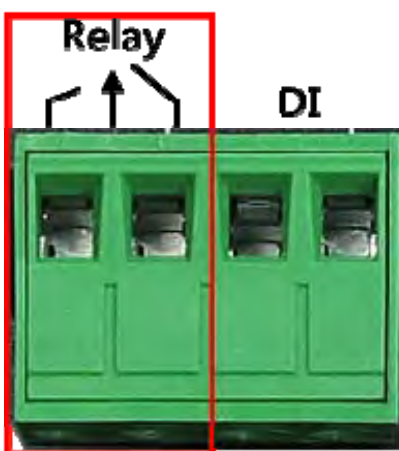

1. Insert the wires into the left two contacts of the 4-contact terminal block (Fault Alarm Relay).
2. Tighten the screws to prevent the wires from loosening.
3. The relay will detect the power and link failure.
4. Users can connect the relay to an alarm and buzzer so that when the relay forms an open circuit, the users will be notified.

WIRING DIGITAL INPUTS

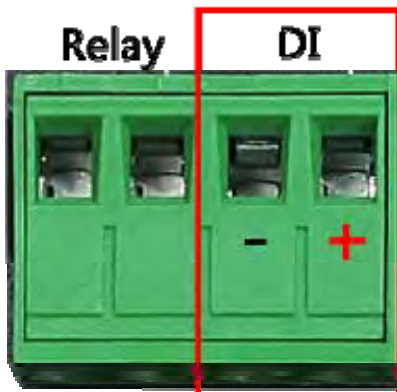

1. Insert the positive and negative wires into the right two contacts (+,-) of the 4-contact terminal block (DI).
2. Tighten the screws to prevent the wires from loosening.
3. The system will detect the voltage go through the DI.
 - +13 to +30V for state "1"
 - -30 to +3V for state "0"
 - Max. input current: 8mA

DOUBLE-SECURE POWER INPUT FAULT ALARM



The power inputs are designed as a "**common negative**", which implies that the negative input is connected, but "**double-secure**" is supported to prevent the unnoticed failure of power from one of the negative inputs. Should one of the negative power inputs fail, the system will detect the failure. **NOTE:** the system will trigger an event occurrence only if the user has set the fault alarm or event log for power.

MOUNTING

Din-Rail Mounting

- a. Screw the DIN-Rail bracket to the switch.
- b. Insert the top of the DIN-Rail bracket to the DIN-Rail track.



- c. Pull down the DIN-Rail bracket to the DIN-Rail track and check if it is mounted tightly on the DIN-Rail track.



INSTALLATION STEPS

1. Unpack

The switch is well packed and shipped to our customers. Unpack it from the box.

2. Check Content Items

Please make sure all the items listed in the "**Package Check List**" are in the box.

3. Mounting

The DIN-Rail is screwed on the switch by default. If the DIN-Rail is not screwed to the switch, refer to the "**DIN-Rail Mounting**" section to install it manually.

4. Power On

To power on the switch, users must prepare a power supply and wire the power input. Refer to the "**Wiring Power Inputs**" section.

The power LEDs are described in the "**LED Instruction**" section.

5. Connect

To connect to the switch, users need a **RJ45 cable**. Insert the RJ45 cable into one of the switch ports and insert the other end to the host such as PC.

The link LEDs are described in the "**LED Instruction**" section.

6. Check LEDs

We recommend the users to check the status of LEDs in the "**LED Instruction**" section. If all the LEDs are in the normal state, the installation is completed.